

OWNER'S MANUAL

HONDA CBR500R

264S-016-130-010



CONTENTS

Page 2	Introduction/Service
Page 3-4	Adjustment
Page 5	Fitting the shock
Page 6-7	Settings/Notes

INTRODUCTION

Multiple adjustment, improved control, refinement and awesome looks make K-Tech Razor shocks a leap beyond standard equipment.

The Razor range of shock absorbers are available in multiple lengths with up to 4 way adjustability allowing you to customise your motorcycle for looks and riding style.

- Increased comfort and control
- Up to 4 way adjustability
- Nitrogen Filled (N²)
- Anodised black finish
- Optional spring rates

*****This product is not designed or intended for highway use.*****

K-Tech Suspension Ltd products are manufactured to fit specific brands and models. Under no circumstances should any K-Tech Suspension Ltd products be fitted to an application other than that for which it has been designed, tested and manufactured.

ADJUSTMENT

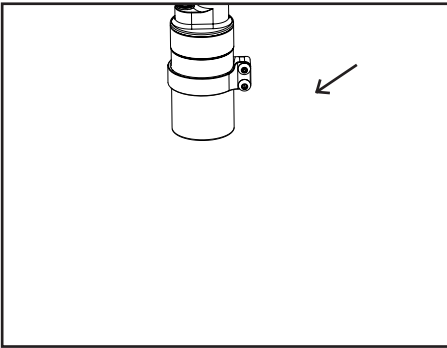

Compression damping:-

Black Adjuster Knob:- 30 clicks adjustment range. All settings should be made from the fully closed (Clockwise Position).

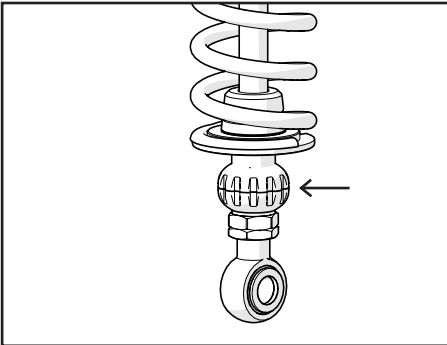

Rebound damping:-

Bottom Adjuster Wheel:- 32 clicks adjustment range. All settings should be made from the fully closed (Clockwise Position).

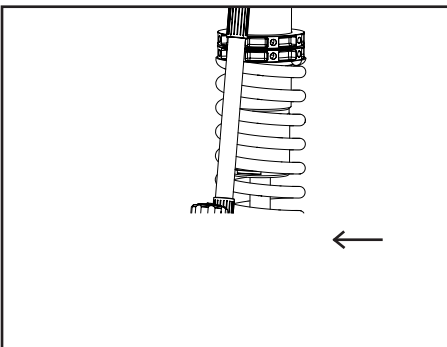

Spring preload:-

Adjust with collars on the main spring. To adjust, unscrew the top collar (anticlockwise). Then turn the bottom collar to the needed preload (1 turn = 1.5mm).

Then secure by tightening the top collar back onto the bottom collar (clockwise).



ADJUSTMENT

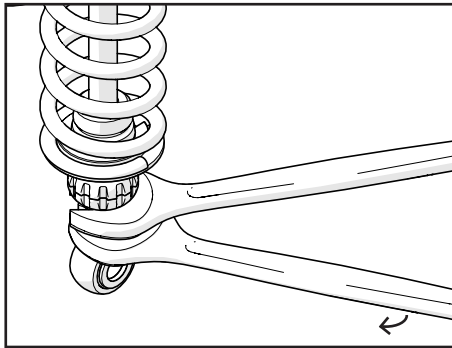

Shock length:-

To adjust the shock length loosen the silver lock nut at the bottom of the shock with a 22mm open ended spanner whilst holding the rod joiner (black 22mm hex) with another spanner.

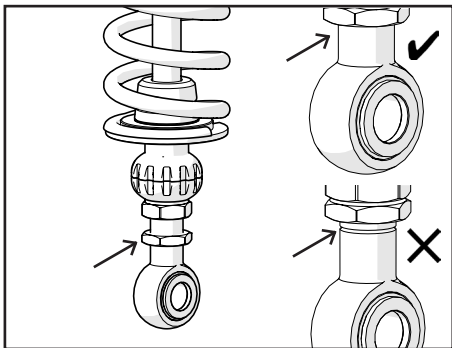

Shock length:-

Turn the end eye assembly until you get the desired length.
(1 turn = 1mm adjustment.)



Make sure you cannot see the groove on the thread.

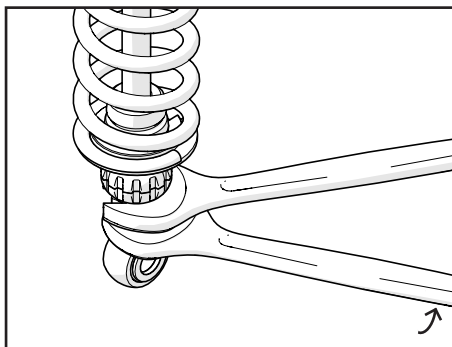

Shock length:-

When you have changed the shock length wind the silver lock nut up to the black rod joiner and torque to 30Nm.

FITTING THE SHOCK

This procedure should only be carried out by a qualified motorcycle technician. K-Tech Suspension Ltd will not be liable for any damages caused in any way to/ by the product and any injuries sustained if the product is fitted by someone who is neither an authorised dealer of K-Tech Suspension Ltd or have the relevant qualifications in motorcycle technology. K-Tech Suspension Ltd will also not be liable if the correct tools are not used throughout the process of fitting and adjustment of a K-Tech suspension Ltd product. Please refer to the manufacturer's workshop manual before attempting this procedure. This procedure will require two people, you will need to remove all relevant bodywork and any other parts that may restrict you from carrying out this task.

Place and secure the motorcycle on an appropriate stand so that the wheel is approximately 5cm off the ground. Loosen top and bottom mounting bolts using the correct spanners. With one person holding the rear wheel in a stationary position the second person can remove the top bolt, it may be necessary to slightly move the rear wheel up and down whilst removing the top bolt. Keeping the rear wheel in a stationary position the second person can now remove the bottom bolt, it will be necessary to hold the shock whilst doing this. Remove the shock from the bike keeping the rear wheel stationary while doing so.

You are now ready to fit the K-Tech Razor shock.

Place the shock into the bike fitting the bottom mounting bolt first, it may be necessary for the second person to slowly move the rear wheel up or down for you to insert the bolt through any linkages.

Now fit the top mounting bolt and torque both top and bottom bolts to the manufacturer's recommendations.

Remove left Pillion Foot Rest Bracket and fit the reservoir bracket to left hand side of the motorcycle using the original fixing points. Re-attach the left pillion foot rest bracket to the bike using the manufacturer's recommended torque setting.

Take a slow test drive to make sure that everything is correct.



www.ktechsuspension.com

Contact your local K-Tech dealer for more details at
www.ktechsuspension.com/service-centres-and-partners