

TRUE TOW

Weight Distribution Hitch
Middle Weight

Why be kinda safe?
When you can be

Weigh Safe!

OWNER'S MANUAL

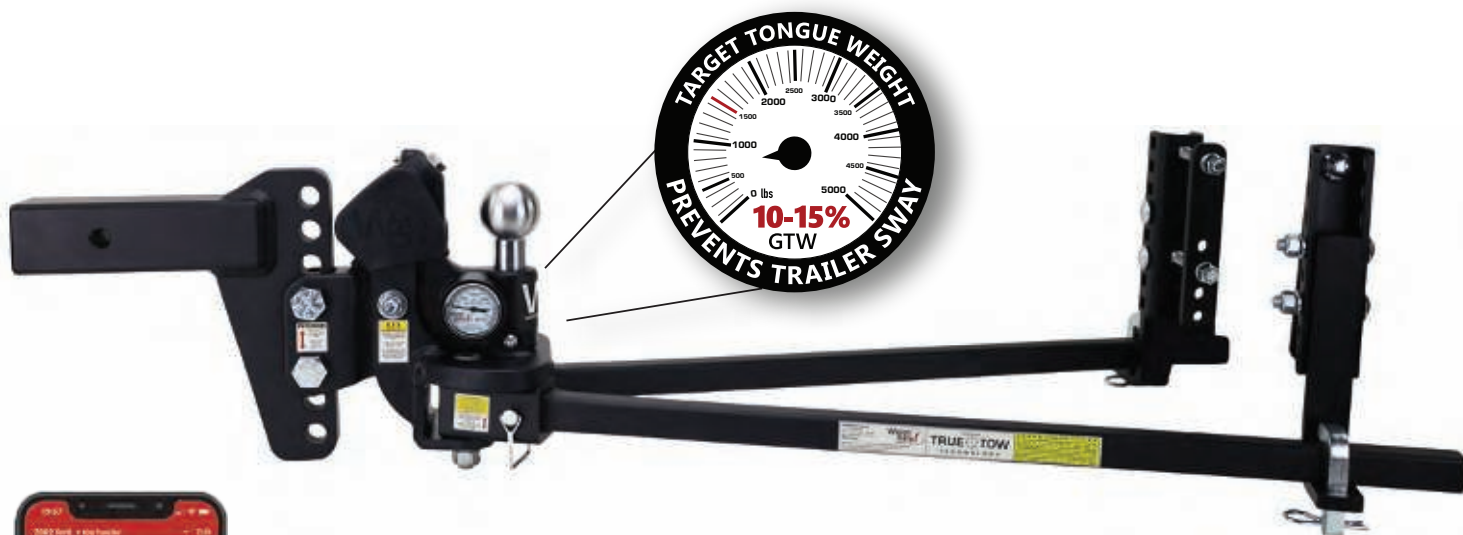

SCAN TO
DOWNLOAD
WEIGH SAFE
TRUE TOW
APP

AVAILABLE SIZES

**DROP
SIZES**

4"
6"
8"
10"

**SHANK
SIZES**

2"
2.5"

WEIGHT RATINGS

**MAX GROSS
TRAILER WEIGHT**

(BASED OFF SPRING ARM SIZE)

**8,500 LBS
12,500 LBS**

Read the entire manual before installation of the Weigh Safe® True Tow Middle Weight Distribution Hitch.

Designed and Engineered in the U.S.A.
Made in China

For additional tools that simplify installation and use, download the Weigh Safe App (iOS and Android devices) or visit our website at www.weigh-safe.com.

Dealers: Please pass this manual to new Weigh Safe customers after hitch installation.

*DTW = Distributed Tongue Weight



WEIGH-SAFE.COM

TABLE OF CONTENTS

IMPORTANT SAFETY INFORMATION.....	3
PARTS BREAKDOWN.....	4
STEP 1 - PRE-SETUP	6
STEP 2 - HEAD ASSEMBLY HEIGHT ADJUSTMENT	6
STEP 3 – TRAILER BRACKET INSTALLATION	8
TRAILER BRACKET LOCATION	8
INSTALLATION OF TRAILER BRACKETS ONTO FRAME.....	8
SETTING HEIGHT OF SPRING ARM PLATFORM.....	9
STEP 4 - SPRING ARM ASSEMBLY.....	9
STEP 5 - DISTRIBUTED TONGUE WEIGHT (DTW).....	10
STEP 6 - CONNECTING SPRING ARMS.....	12
STEP 7 - LIVE WEIGHT DISTRIBUTING SYSTEM	12
STEP 8 - DISCONNECTING YOUR HITCH.....	14
STEP 9 - REGULAR INSPECTION AND MAINTENANCE	14
LIMITED WARRANTY	16

Required Tools

- DTW calculator on the Weigh Safe True Tow App or at www.weigh-safe.com (required to properly adjust hitch).
- Measuring tape
- Lift Arm with ¾" socket end (provided)
- Torque wrench capable of 150 ft-lb
- ¾" socket
- 1-1/8" socket



SCAN FOR
DTW
CALCULATOR

Attention Weigh Safe Hitch Owner

Keep This Manual

Please keep this manual available for reference in the event you do not have access to the Weigh Safe True Tow App or to our website at www.weigh-safe.com.

Replacement:

This manual is available on the Weigh Safe True Tow App and on our website at www.weigh-safe.com. You can also request a replacement copy by calling Weigh Safe Customer Support at (801) 820-7020.

Further Assistance:

For help installing or using your Weigh Safe True Tow Middle Weight Distribution Hitch, please contact a qualified Weigh Safe Dealer in your area, call Weigh Safe Customer Support at (801) 820-7020, or email us at support@weigh-safe.com.

IMPORTANT SAFETY INFORMATION

FAILURE TO FOLLOW ALL SAFETY WARNINGS MAY RESULT IN SEVERE INJURY OR DEATH

WARNING

Installing, setting up, and measuring weight distribution appropriately does NOT guarantee safe towing. The vehicle operator is responsible to optimize weight distribution and sway control by making necessary adjustments. However, each trip and load are different. The weight distribution setup and towing performance should be evaluated by the vehicle operator and adjusted appropriately both before and during the tow.

Responsibility falls on the driver to properly adjust the towing equipment and to adjust his or her driving habits to account for the trailer requirements, the towing conditions, and the road conditions. The driver alone is responsible for their own safety and the safety of any passengers in the vehicle. Towing with a tongue weight of less than 10% or more than 15% of the gross trailer weight greatly increases the likelihood for loss of vehicle control.

Thoroughly read, understand, and follow all safety warnings, setup, use, and maintenance instructions of your tow vehicle, trailer, and towing/hitching equipment prior to installing your hitch and before towing your trailer.

Even if a dealer installed your hitch, verify that the hitch is properly adjusted after loading your trailer onto the tow vehicle prior to your trip.

This hitch setup does not guarantee that trailer sway will be avoided altogether.

ALWAYS load the contents of a trailer correctly and properly. Follow tow vehicle and the trailer manufacturer's recommendations for quantity and placement of cargo.

ALWAYS use a tow ball with a weight rating that meets or exceeds the Gross Vehicle Weight (GVW) requirements for your specific trailer.

ALWAYS use a tow ball size that matches your trailer's coupler size and double check to make sure the tow ball and the trailer coupler are properly and securely joined prior to towing.

ALWAYS inspect all fasteners prior to each trip for wear/tear and fatigue. Ensure all nuts, bolts, pins, and clips are tightly and securely in place. Do NOT tow your trailer until all fasteners have been checked.

NEVER tow until your hitch is properly adjusted.

NEVER exceed the weight rating specified for the tow vehicle, trailer, hitch, tow ball, or any other towing equipment.

NEVER cut, weld, grind, bend, or modify any of the hitch components in any way.

NEVER tow or back up with spring arms attached if the angle between tow vehicle centerline and trailer centerline is greater than 60 degrees. Unhook spring arms while backing up to avoid this. Failure to do so may cause damage or hitch failure and will void warranty.

NEVER tow with your spring arms attached in extreme road conditions including, but not limited to, on rough roads, through ditches or dips, or while launching a boat. Excessive strain on the spring arms and hitch head may cause hitch fatigue and/or failure.

NEVER transfer your hitch to a different tow vehicle or trailer without re-adjusting the hitch for proper setup and weight distribution required by the new tow vehicle.

CAUTION

Do **NOT** loosen or remove any part of the hitch while the hitch is in use with a trailer hooked up. Use the trailer tongue jack to remove the tension from the Spring Arms prior to removing the L-Fingers.

ALWAYS secure the tow vehicle and trailer by applying the parking brake and wheel stops prior to setup or adjustments.

To avoid excessive strain on the hitch assembly, disengage spring arms prior to towing or backing up the trailer across a significant transition in grade (e.g. backing from a flat street to a steep uphill driveway).

PARTS BREAKDOWN

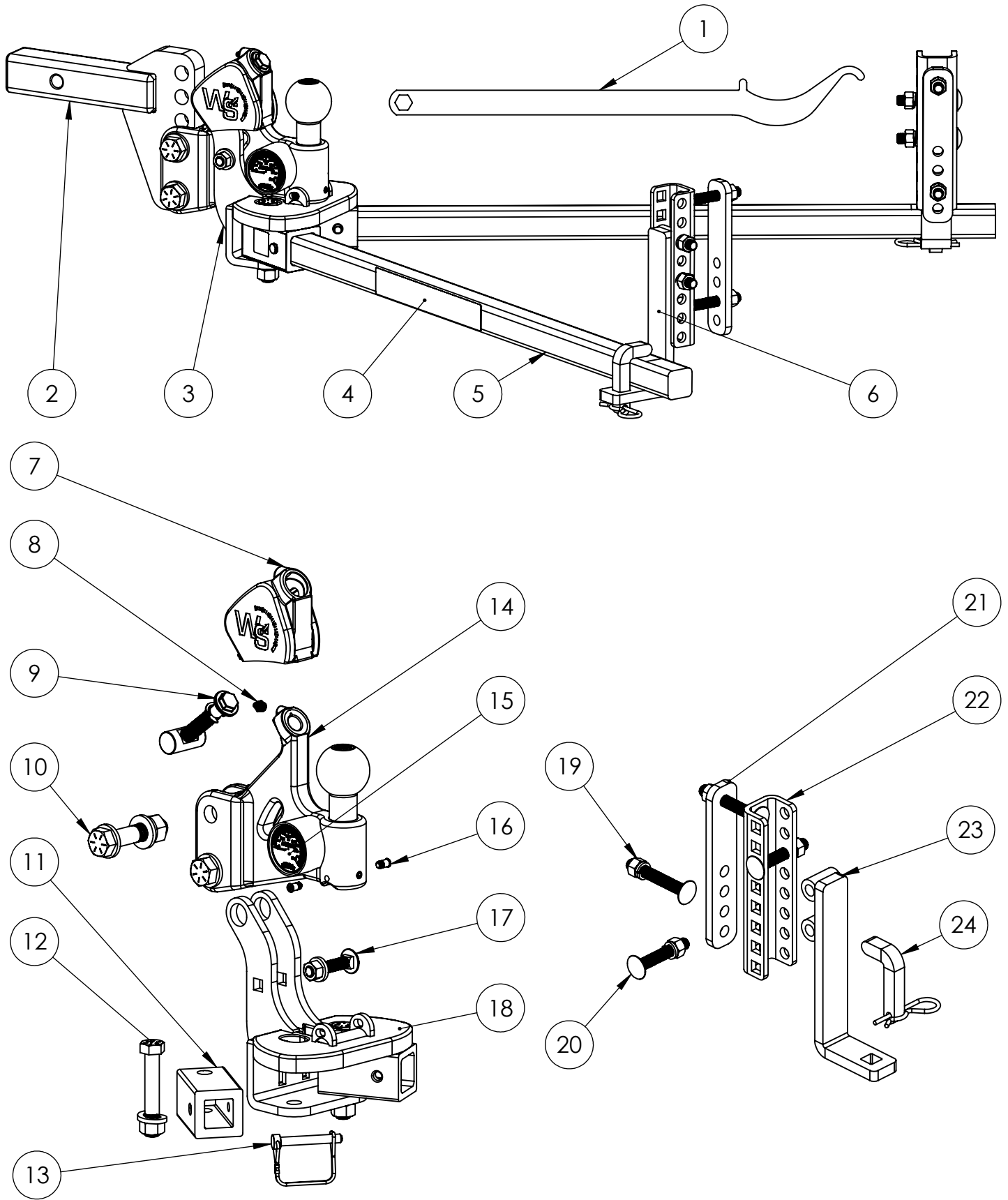

PARTS BREAKDOWN

ITEM #	PART #	PART DESCRIPTION	QTY PER HITCH
1	TTLA	LIFT ARM	1
2	TTDB4-2	DRAW BAR 4" DROP W/ 2" SHANK	1
	TTDB4-2.5	DRAW BAR 4" DROP W/ 2.5" SHANK	
	TTDB6-2	DRAW BAR 6" DROP W/ 2" SHANK	
	TTDB6-2.5	DRAW BAR 6" DROP W/ 2.5" SHANK	
	TTDB8-2	DRAW BAR 8" DROP W/ 2" SHANK	
	TTDB8-2.5	DRAW BAR 8" DROP W/ 2.5" SHANK	
	TTDB10-2	DRAW BAR 10" DROP W/ 2" SHANK	
	TTDB10-2.5	DRAW BAR 10" DROP W/ 2.5" SHANK	
3	TTSL-MLD	HEAD ASSEMBLY	1
4	TT04-LD	8.5K SPRING ARM STICKER PACK	1
	TT04-MD	12.5K SPRING ARM STICKER PACK	
5	TTSARM-LD	1.2" SPRING ARMS	2
	TTSARM-MD	1.375" SPRING ARMS	
6	TTBR	TRAILER BRACKET ASSEMBLY	2
7	TT07	LEAD SCREW DUST COVER	1
8	TT08	GREASE ZERKS	2
9	TT09	LEAD SCREW ASSEMBLY	1
10	TT10	HEIGHT ADJUSTMENT BOLT ASSEMBLY	2
11	TT11	LD/MD SOCKETS	2
12	TT12	SOCKET BOLT ASSEMBLY	2
13	TT13	CLEVIS PIN WITH WIRE	2
14	TT14	SLIDER	1
15	TT15	GAUGE REPAIR KIT	1
16	TT16	BALL RETAINING SCREWS	2
17	TT17	CLAMP BOLT ASSEMBLY	1
18	TT18	PIVOT ARM WELD ASSEMBLY	1
19	TT19	3.5" CARRIAGE BOLT ASSEMBLY	4
20	TT20	3" CARRIAGE BOLT ASSEMBLY	4
21	TT21	INSIDE FLAT BRACKET	2
22	TT22	OUTSIDE C CHANNEL BRACKET	2
23	TT23	SPRING ARM PLATFORM	2
24	TT24	L-FINGER AND PIN	2

*DTW = Distributed Tongue Weight



INSTALLATION

Step 1 - Pre-Setup

Park your trailer and tow vehicle on flat level ground in line with each other. Put wheel stops on trailer wheels and uncouple trailer from the tow vehicle. Pull the tow vehicle forward 4 to 5 feet to allow for working space.

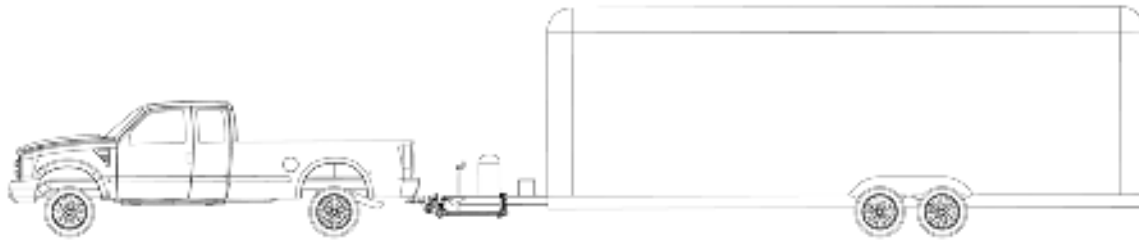

With the Weigh Safe® True Tow Middle Weight Distribution Hitch, setup is dependent on the measured tongue weight for each separate tow. Be sure to measure your tongue weight without Spring Arm attachment prior to each connection and adjust your hitch according to the instructions below. Tongue weight will change with the varying levels of the propane and freshwater tanks, and any other cargo the trailer will carry, including toys for toy haulers.

Check and inflate all tires of the system to the proper pressure before every trailer and tow vehicle connection.

Step 2 – Head Assembly Height Adjustment

THE GOAL OF THIS STEP IS TO HELP LEVEL YOUR TRAILER WHEN YOU'RE ON THE ROAD TOWING!

NOTICE: *If you don't know your actual tongue weight, quickly measure your tongue weight by putting on the head assembly at a best guess height and lower your trailer onto the tow ball completely. The gauge will show your tongue weight. Continue with instructions to set head assembly height correctly.*

Level the trailer to be parallel to the ground. This can be done by measuring the front and back of the trailer frame to the ground. Adjust where needed so both the front and back measurements are the same.

With the trailer level, measure from the ground to the top of the trailer coupler. The top of the Tow Ball on the Head Assembly should be some distance above this measurement. The distance will depend on what the tongue weight of the trailer is and what kind of suspension is on the tow vehicle. A good rule of thumb is to set the Tow Ball $\frac{1}{8}$ " higher for every 100 lbs. of tongue weight. See *Figure 1*.

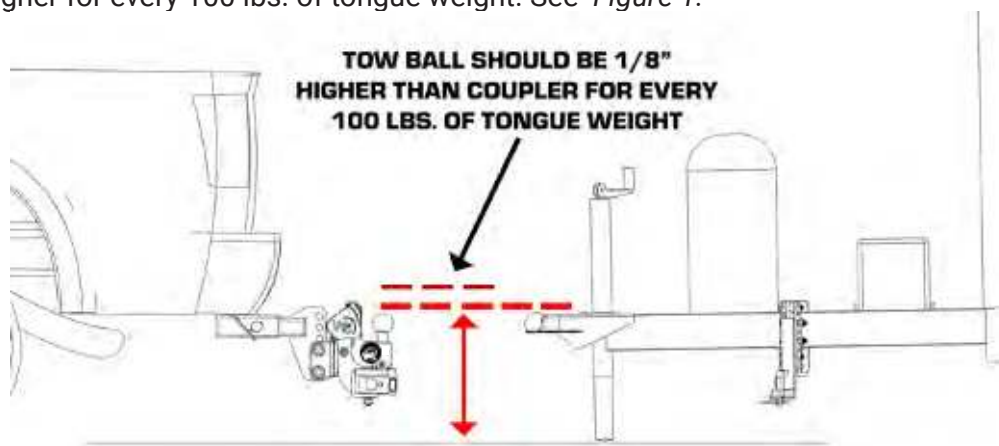

Figure 1

INSTALLATION

Insert the correct size of Draw Bar into the receiver of the tow vehicle. Depending on what the height of the trailer coupler is, the Draw Bar may need to be in the rise or drop position. See *Figure 2*.

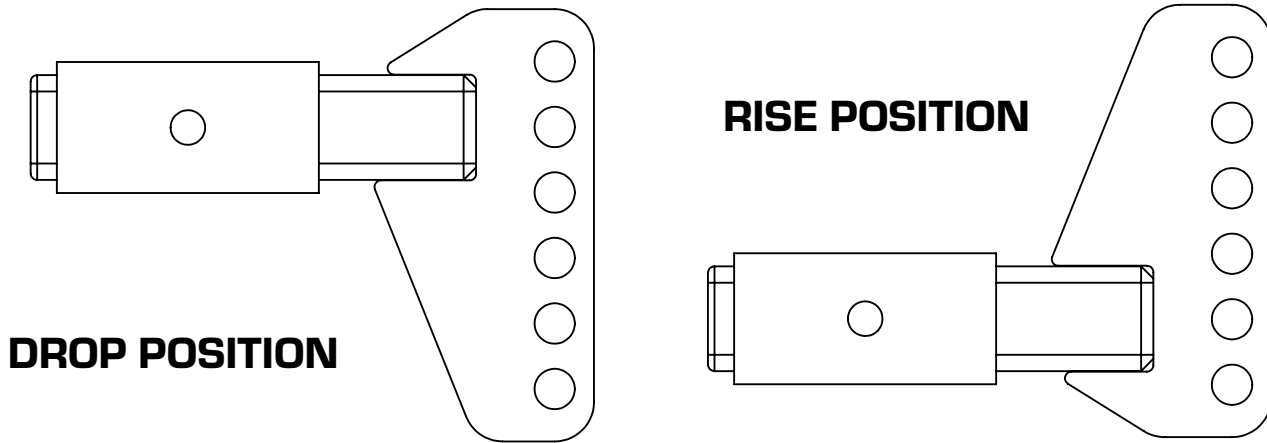
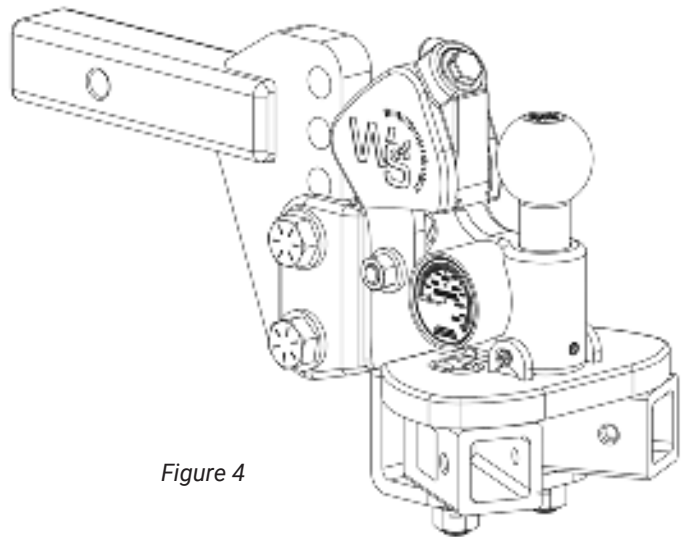
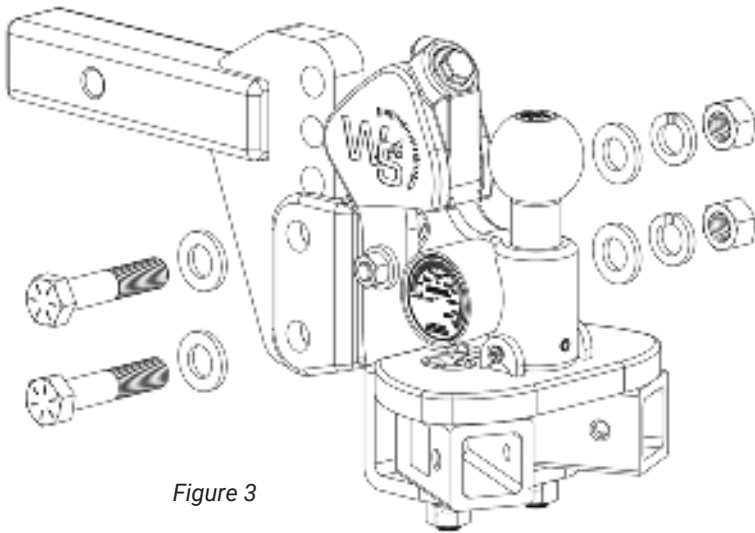

Figure 2

Slide the Head Assembly onto the Draw Bar and insert the Grade 8 Bolts and washers into their correct holes to set the ball height. Make sure to add both the washer and flat lock washer in between the bolt and slider. Torque bolts to 150-320 ft/lbs. See *Figure 3* and *Figure 4*.



For future reference, save your height setup into the DTW tool on the Weigh Safe True Tow App by inputting both your Draw Bar position (rise or drop) and how many empty holes are visible above the top of the Head Assembly on the Draw Bar. Or, if you are using the website, save your height setup here:

Rise / Drop (circle one)

Empty holes visible: _____

INSTALLATION

Step 3 - Trailer Bracket Installation

Trailer Bracket Location

Locate the center-line of where the trailer brackets need to be placed by measuring from the center of the trailer coupler along the trailer frame and put a mark at 32" on both sides. Ensure there are no brake lines, electrical wiring, or gas lines that would be in the way of the trailer brackets. If something is obstructing the placement of the trailer brackets, it will need to be re-routed or avoided to prevent damage by the trailer brackets.

Sometimes there may be a frame member, propane mount, or battery mount in the way that cannot be moved. In these cases, the trailer brackets can be moved forward, closer to the trailer coupler down to a minimum distance of 27" from the coupler center. See *Figure 5*.

Securing the trailer brackets at the 32" mark will put the least amount of stress on the trailer and hitch, providing the safest tow. The further back the trailer brackets, the less stress on your tow vehicle, hitch and trailer.

Installation of Trailer Brackets onto Frame

Place one of the ½" x 3-½" Carriage Bolts through the top hole in the Outside C Channel Bracket and align it with the top hole of the Inside Flat Bracket. Slide on the ½" Lock Washer and thread on the ½" Nut a couple of turns. See *Figure 6*.

Slip the brackets over the trailer frame and line up the top bolt with the center-line mark from the previous step. Tighten the nut until hand tight.

Insert the second ½" x 3-½" Carriage Bolt in the highest open hole in the Outside C Channel Bracket under the trailer frame and press it through the corresponding hole on the Inside Flat Bracket. Slide on the ½" Lock Washer and thread on the ½" Nut until hand tight. See *Figure 7*.

There should not be a gap between the top and bottom Carriage Bolts and the trailer frame. If there is a gap larger than ½" it can cause damage to the trailer brackets.

Use ¾" socket end of Lift Arm or ¾" socket/torque wrench and tighten the ½" nuts. Be sure to alternate between the top and bottom nuts to avoid over tightening one and not being able to completely tighten the other one. Over tightening one can cause damage to the brackets.

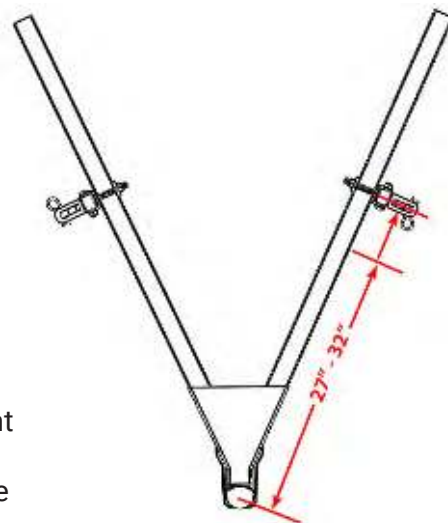

Figure 5

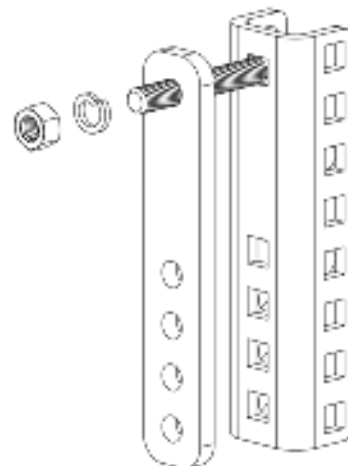

Figure 6

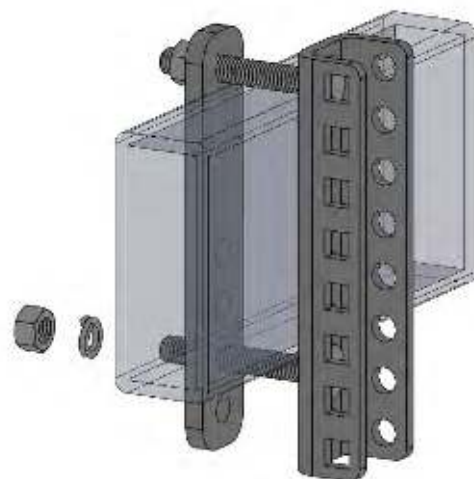

Figure 7

INSTALLATION

Setting Height of Spring Arm Platform.

Slide the Spring Arm Platform between the Outside C Channel Bracket and set it to the correct height. The ideal height for the flat portion of the platform is as close to 9" below the top of the trailer coupler. See *Figure 8*. This will allow the Spring Arms to be horizontal with the trailer frame which will create the smoothest tow. In some cases, if the lead screw on the Head Assembly tops out before you reach your DTW* (make sure to loosen the clamp bolt before adjusting the lead screw), the Spring Arm Platform might need to be less than 9".

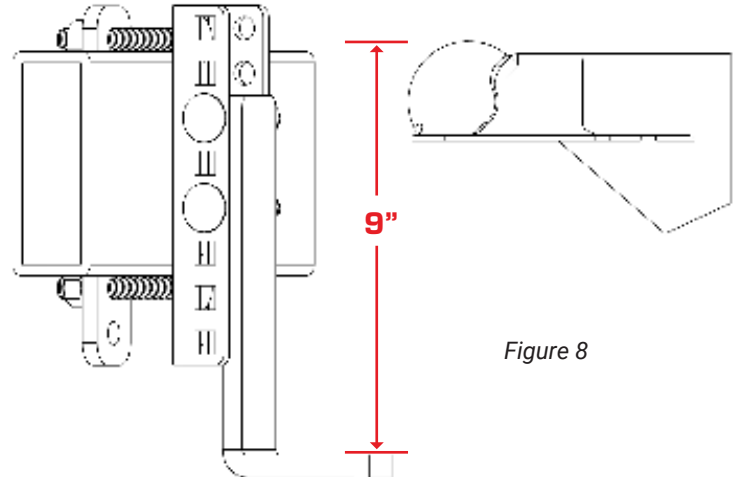

Figure 8

Once you have the Spring Arm Platform set to the correct height, insert two ½" x 3" Carriage Bolts into the square holes in the Outside C Channel Bracket that lines up with the corresponding holes in the Spring Arm Platform. Press them all the way in, slide on a ½" Lock Washer and thread on the ½" Nut on each bolt. See *Figure 9*. Tighten to hand tight. Then use the ¾" socket/torque wrench and tighten the ½" nuts. All trailer bracket bolts will need to be torqued to 65 ft-lb.

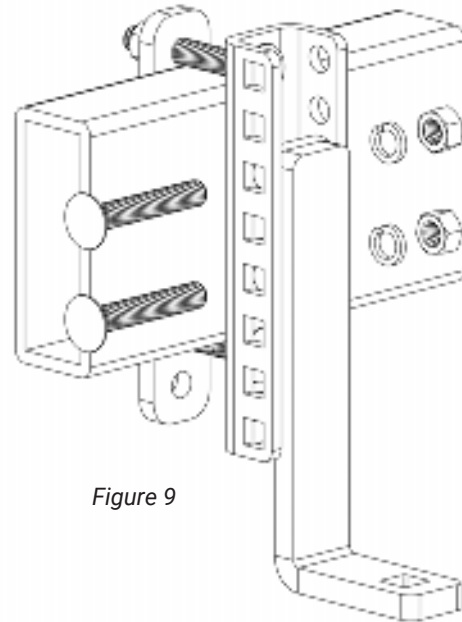

Figure 9

Repeat these steps on the other side of the trailer frame for the other trailer bracket.

Step 4 - Spring Arm Assembly

WARNING

USING A TORQUE WRENCH, CONFIRM THAT THE SPRING ARM SOCKET BOLTS ARE TORQUED TO A MINIMUM OF 60 FT-LB TORQUE BEFORE EACH TOWING SESSION.

NOTICE: *The Spring Arm Sockets are being compressed by Socket Bolts in the Head Assembly and are hard to twist. This is to help with sway control. Do not pound directly on the Spring Arm Sockets. This could cause them to chip or crack. Use the Spring Arms as a lever to move the compressed Spring Arm Sockets.*

Insert the Spring Arms into the Spring Arm Sockets so the hole in the Spring Arm lines up with the hole on the Spring Arm Socket.

Insert the Clevis Pin into the hole from the outside to the inside of the hitch. This is to allow you to remove this pin even if the spring arms are close together. Secure the Clevis Pin with the attached wire. Repeat these steps on the other side. See *Figure 10* and *Figure 11* (on next page).

INSTALLATION

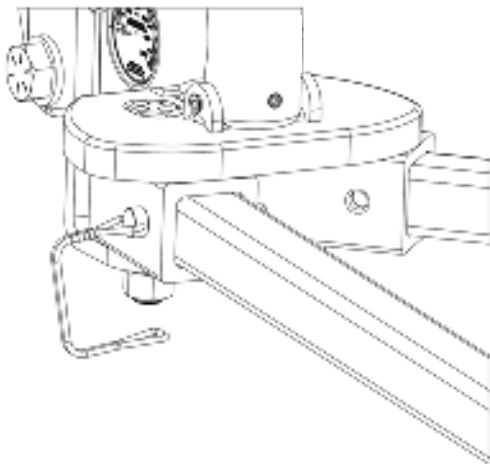

Figure 10

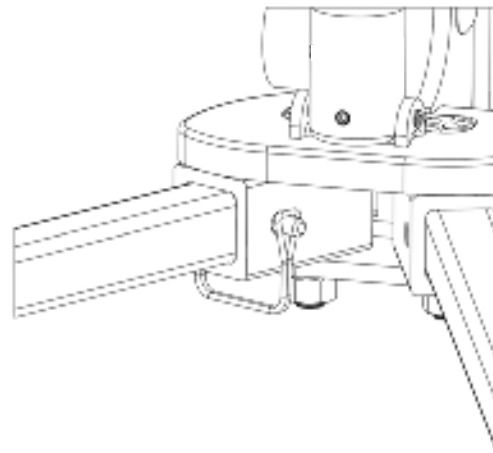

Figure 11

Note: Make sure to swing spring arms outward before backing up to prevent damage from happening to your trailer, trailer brackets and spring arms.

Step 5 - Distributed Tongue Weight (DTW)

NOTICE: For the following steps, it is required that you use the DTW tool found on the Weigh Safe True Tow App or on www.weigh-safe.com. The Weigh Safe True Tow Middle Weight Distribution Hitch not only provides you with the ability to measure tongue weight, it will also accurately calculate how much the Spring Arms need to be loaded in order to provide a truly distributed towing system. This load is reflected in an added amount of force between the ball and coupler, increasing the read out on the Weigh Safe gauge. **This is NOT adding tongue weight to your vehicle.** That weight is called the Distributed Tongue Weight. Without the DTW tool, you will not be able to accurately calculate the correct DTW* to set up your system appropriately.

Input your Gross Trailer Weight (GTW) into the DTW tool. Gross Trailer Weight is the overall loaded weight of the trailer. Back up the tow vehicle to the trailer and lower the trailer coupler onto the Tow Ball. Lock the coupler and insert safety pin/lock for a secure attachment. Continue retracting the trailer tongue jack until it raises off the ground. Jounce your trailer to reduce all friction points. Look at your Weigh Safe gauge and input your tongue weight into the DTW tool. Make sure your tongue weight is within a 10-15% range of your GTW.

Once you have your tongue weight inputted, you will need to take three measurements of your towing system to get the correct DTW*. To take dimensions, pull out one of the Spring Arms until the bar is perpendicular to the Head Assembly. This arm will be used as a base point to take measurements. Always measure using the side of the Spring Arm closest to the tow vehicle. See Figure 12. Insert the following three measurements into the DTW tool or if you are using the website, save your measurements on the provided lines.

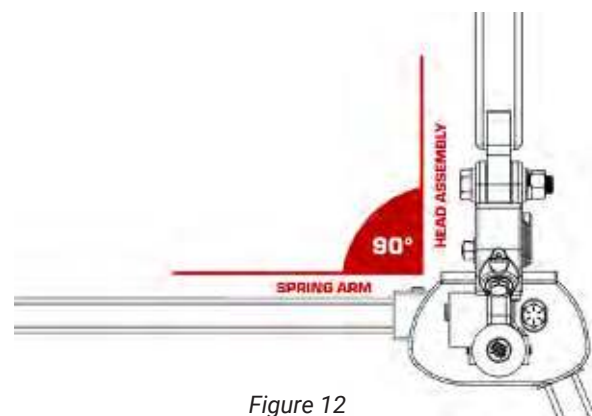

Figure 12

INSTALLATION

Measurement #1

In inches, measure in a straight line from the rear vehicle axle center-line to the Spring Arm (*always measure using the side of the Spring Arm closest to the tow vehicle*). See Figure 13. Record measurement in the app or below.

Measurement: _____

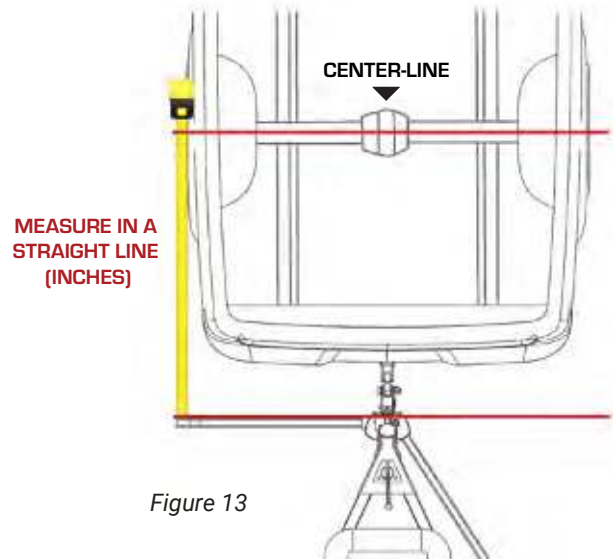

Figure 13

Measurement #2

In inches, measure in a straight line from the Spring Arm to the center of the trailer brackets (*always measure using the side of the Spring Arm closest to the tow vehicle*). See Figure 14. Record measurement in the app or below.

Measurement: _____

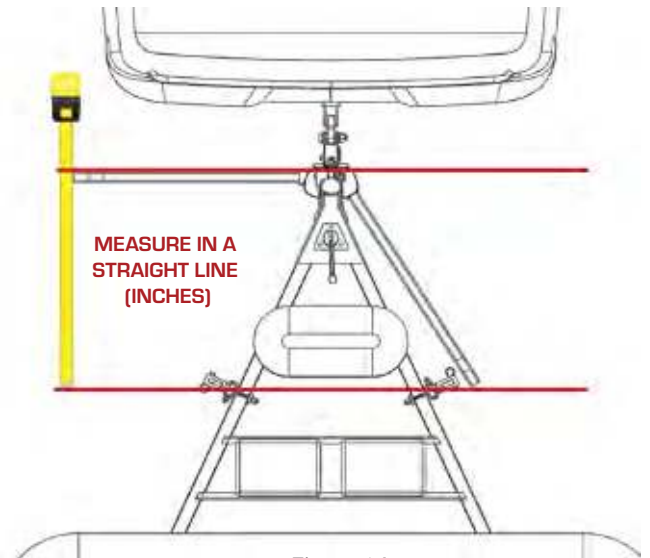

Figure 14

Measurement #3

In inches, measure in a straight line from the Spring Arm to the center-line of a single axle or center-line between multiple axles (*always measure using the side of the Spring Arm closest to the tow vehicle*). See Figure 15. Record measurement in the app or below.

Measurement: _____

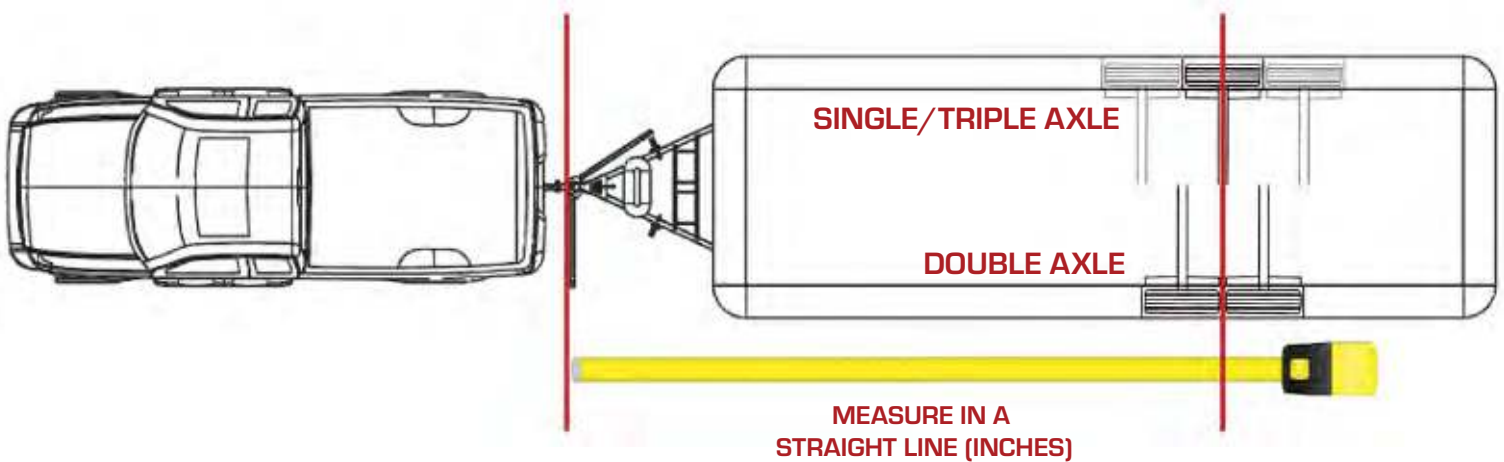

Figure 15

INSTALLATION

Step 6 - Connecting Spring Arms

Now that you know your DTW*, it is time to hook up the Spring Arms.

With the trailer still coupled to the tow vehicle, use the trailer tongue jack to lift both tow vehicle and trailer until you can swing the Spring Arms into place over the Spring Arm Platforms. If you reach the highest level or load of the trailer tongue jack and the Spring Arms are unable to be lifted onto the Spring Arm Platforms, you can use the Lift Arm to lift the Spring Arms up onto the Spring Arm Platforms. See *Figure 16*.

Use the L-Fingers and L-Finger Pins to secure the Spring Arms onto the Spring Arm Platforms. See *Figure 17*.

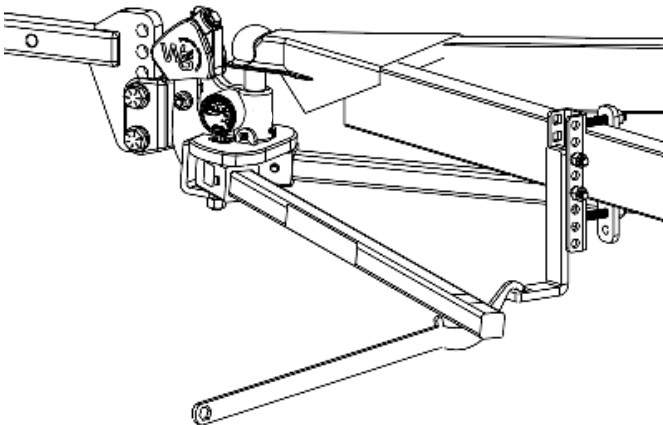

Figure 16

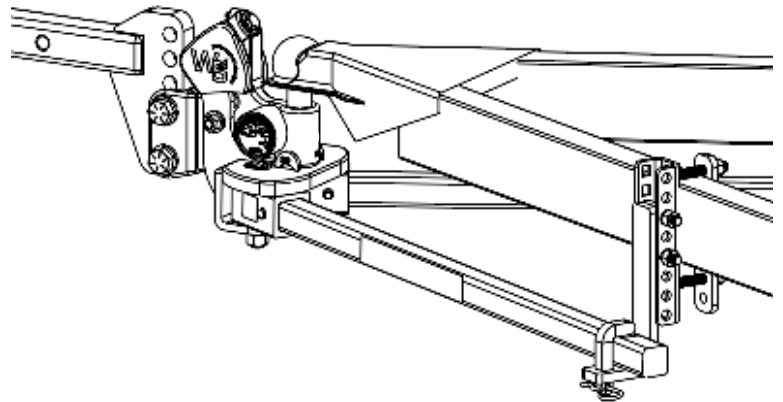

Figure 17

Repeat step for both Spring Arms on each side of the trailer.

Step 7 - Live Weight Distributing System

! WARNING

NEVER TOW WITH SPRING ARMS IN HIGHEST POSITION (LEAD SCREW LOOSENED ALL THE WAY). SEE FIGURE 18. IT CAN CAUSE EXTREME FORCES ON LEAD SCREW AXLE WHICH CAN RESULT IN HITCH FAILURE AND WILL VOID WARRANTY.

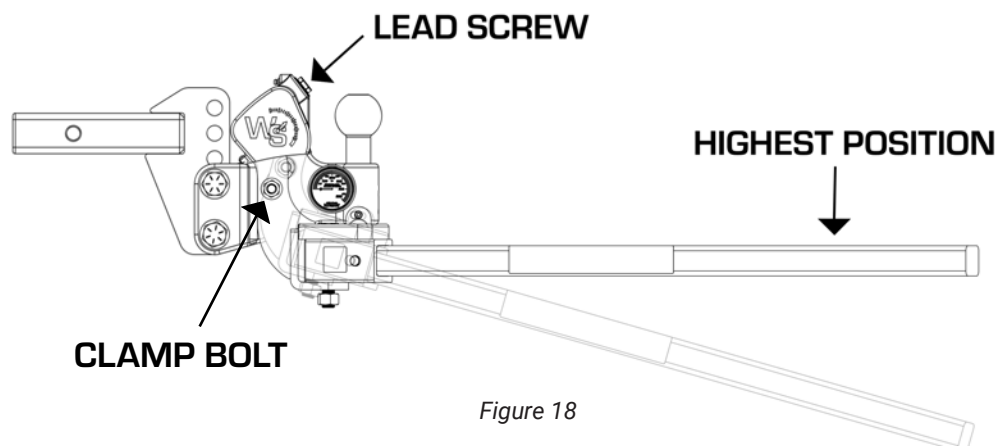

Figure 18

INSTALLATION

Now that the Spring Arms are attached to the trailer, it is time to distribute your towing system using the calculated DTW* populated on the DTW tool. Before adjusting your lead screw make sure to loosen the clamp bolt with a 3/4" socket/torque wrench. Then using the Lift Arm or a 3/4" socket/torque wrench, tighten or loosen the lead screw until your Weigh Safe gauge reaches the DTW* number. Turning it clockwise increases distributed tongue weight and counterclockwise decreases distributed tongue weight. See *Figure 19*. Every few turns, jounce the trailer to reduce built up friction points. Make sure to retighten your clamp bolt (See *Figure 18*) after adjusting your lead screw (35-65 ft lbs). See notice below.

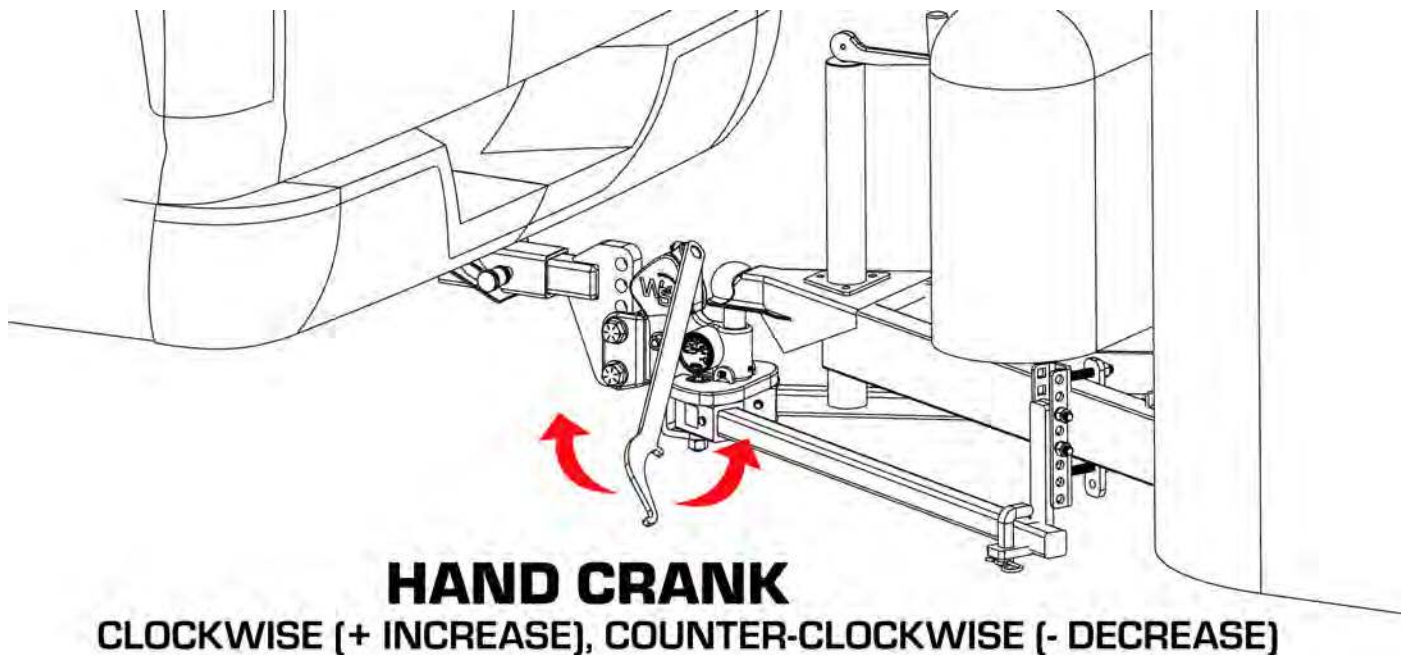

Figure 19

Once the Weigh Safe gauge has reached the DTW* Safe Zone, your system is now distributed. It is important to note that the DTW* will normally, but not always, read somewhere between 2-3 times your tongue weight, which is allowed to be higher than the max tongue weight rating of your hitch.

DO NOT PULL TRAILER WITHOUT DTW ACHIEVED.

Yes, it was that easy.

NOTICE: Sometimes the added force in the Spring Arms can cause extra friction in the Tow Ball resulting in slow or no change in the tongue weight while adjusting the Lead Screw. If you are noticing your system not moving after a substantial amount of adjusting, jounce (stand on or kick the tongue of) your trailer to loosen up the high friction.

INSTALLATION

Step 8 - Disconnecting Your Hitch

Pull your trailer into the place you want it parked; most effectively done on a flat surface.

Set the parking brake and put stops under the wheels of the trailer.

Unhook the electrical cord, chains, and breakaway cable from the tow vehicle.

Raise the trailer tongue jack until it starts to raise both the trailer and tow vehicle. Continue to raise until the weight is lifted off the ends of the Spring Arms, allowing you to easily pull off the Spring Arms from the Spring Arm Platforms.

Remove L-Finger Pins and L-Fingers.

Slide Spring Arms away from the trailer frame to clear the trailer brackets when you lower the trailer tongue jack.

Lower the trailer tongue jack until the trailer tongue is again resting on the hitch (showing some tongue weight) and you can unhook the trailer coupler latch.

Use the trailer tongue jack to lift the trailer off the Tow Ball and pull the tow vehicle away from the trailer.

Unhook the Spring Arms from the Head Assembly and remove the Head Assembly from the Draw Bar.

Store your True Tow Middle Weight Distribution Hitch in a safe and secure location that is protected from weather conditions.

Step 9 - Regular Inspection and Maintenance

WARNING

Do not tow your trailering system unless all bolts and nuts have been properly checked and tightened and all pins and brackets are securely installed. Towing with loose bolts or pins for an extended period can cause abnormal stress on the hitch resulting in accident, severe injury, and/or property damage.

Check that all bolts and nuts are torqued to the specified amount before every tow. See *Table 1*.

Torque Specifications		
Clamp Bolt	35 -65 ft-lbs	Item # 17
Trailer Bracket Bolts	65 ft-lbs	Item # 19 & 20
Spring Arm Swivel Bolts	60-150 ft-lbs	Item # 12
Slider Bolts	150-320 ft-lbs	Item # 10

Table 1

INSTALLATION

Check all plugs and screws in the Head Assembly to make sure that none have backed out or are leaking any hydraulic fluid.

On the Head Assembly, the friction surfaces should be kept clean and well lubricated with high-pressure multipurpose grease or bearing grease. The best way to apply the grease is to twist the Spring Arm Sockets completely to the outside positions and apply grease to the top of the Spring Arm Sockets and where they contact the rest of the Head Assembly. See *Figure 20A* and *Figure 20B*.

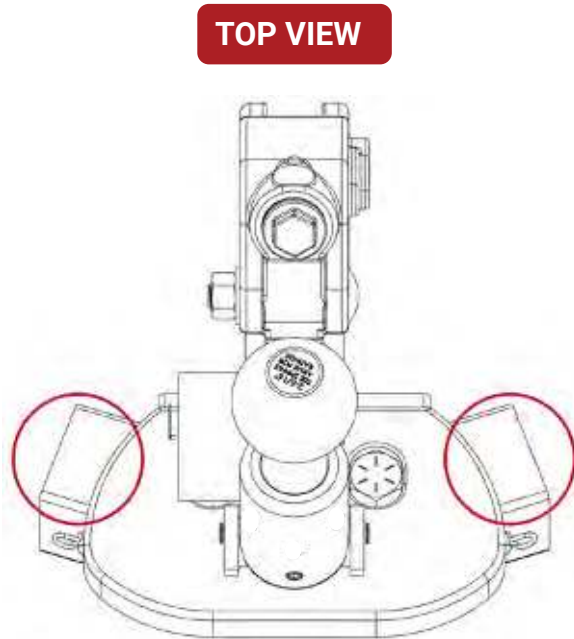

Figure 20A

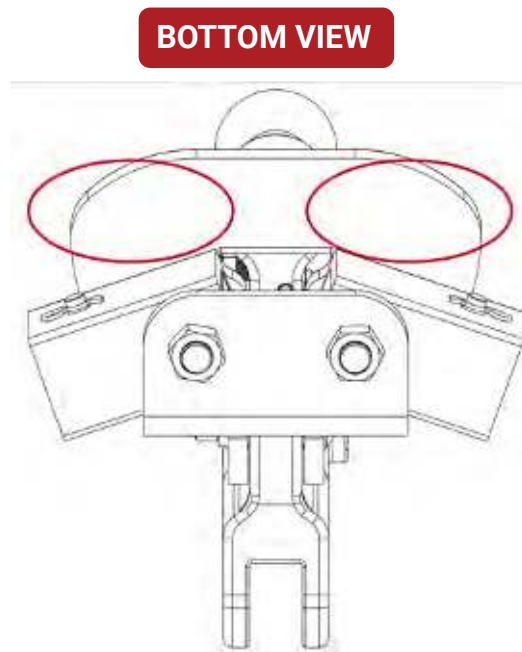

Figure 20B

There are also two grease ports on the Head Assembly that supply grease to the Lead Screw that needs to be serviced at the beginning of each towing season or bi-annually in warmer climates. To service, use a grease gun filled with high-pressure multipurpose grease or bearing grease and pump into ports. To access the lower grease port, the Lead Screw will need to be loosened into its lowest position. Fill the top and bottom ports generously to keep areas well lubricated. See *Figure 20*.

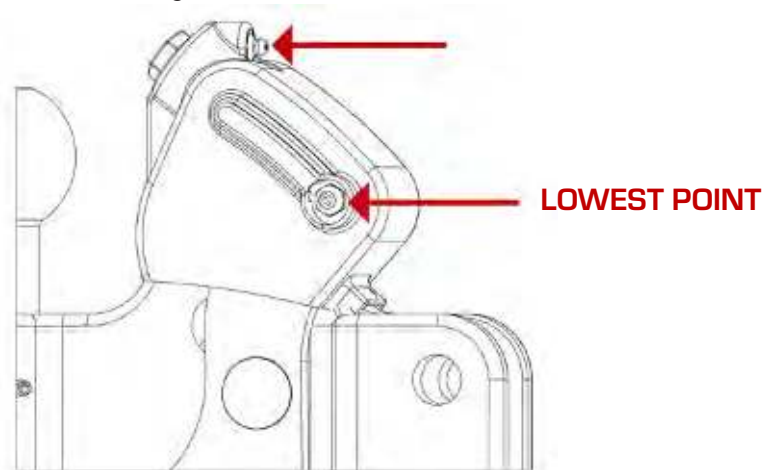

Figure 20

LIMITED WARRANTY

***TO OBTAIN BENEFITS of this warranty you MUST: REGISTER ON LINE (within 30 days of original date of purchase)

Weigh Safe, LLC warrants to the original buyer of this Weigh Safe® (the "product") that –under normal and ordinary use and service—the product will be free from defects in materials and workmanship. If the product includes a latent defect, the product will be repaired or replaced at Weigh Safe's option. Proof of purchase required. Register your product at www.weigh-safe.com within thirty (30) days of purchase to guarantee warranty service and to receive product updates.

This warranty does not cover normal wear and tear and also does not apply to any product (i) beyond its expected useful life; (ii) that has been modified or altered; (iii) damaged as a result of improper installation, improper maintenance, or unreasonable use including, without limitation, loading the product beyond its factory-rated load capacity; (iv) damaged in a collision; or (v) that has suffered any other damage.

This warranty does not cover the finish on any Weigh Safe product which includes machined, brushed, cerakoted, painted/powder coated, or chrome-plated finishes.

The Company shall not be liable for any consequential, incidental, indirect, penal, or special damages arising out of any act or failure to act, even if the Company has been advised of or has foreseen the possibility of such damages. Customer assumes all risk of injury resulting from use of the product.

EXCEPT AS EXPRESSLY SET FORTH IN THIS LIMITED LIFETIME WARRANTY, THE PRODUCT IS SOLD "AS IS" WITH ALL FAULTS AND WITHOUT WARRANTY OF ANY KIND, EXPRESS OR IMPLIED, INCLUDING WITHOUT LIMITATION, ANY WARRANTY OF MERCHANTABILITY OR FITNESS FOR ANY PARTICULAR PURPOSE.

For warranty service, Customer must first contact the Company and obtain a return authorization number, then return the product to the Company, at Customer's expense. Customer will be responsible to pay any labor costs and all shipping charges to return the product to Customer.

In order to receive full warranty benefits the products must be returned in it's originally packaged state or according to Weigh Safe product return requirements.

Contact Customer Service at (801) 820-7020 or returns@weigh-safe.com.

CHECK OUT OUR OTHER PRODUCTS!

STEEL WEIGH SAFE PINTLE HITCH

The Steel Weigh Safe Pintle Hitch is the only pintle hitch on the market that has the ability to measure tongue weight!



SAFE LOAD GOOSENECK PRODUCTS

The only gooseneck products that measure tongue/pin load weight. Available for the B&W Turnover Hitch, OEM puck systems, and in-bed rails.

WEIGH SAFE ADJUSTABLE BALL MOUNT

Weigh Safe Hitch measures your tongue weight signaling you to adjust your load! Available in Brushed Aluminum, Black Cerakote Aluminum & Black Powder Coated Steel.

