



© 2020–2022

by S&S® Cycle, Inc.

All rights reserved.

Printed in the U.S.A.

Installation Instructions: S&S Grand National 2-1 Exhaust System for Indian Scout Models (4111-156/4111-266)

DISCLAIMER:

Many S&S parts are designed for high performance, closed course, racing applications and are intended for the very experienced rider only. The installation of S&S parts may void or adversely affect your factory warranty. In addition such installation and use may violate certain federal, state, and local laws, rules and ordinances as well as other laws when used on motor vehicles used on public highways. Always check federal, state, and local laws before modifying your motorcycle. It is the sole and exclusive responsibility of the user to determine the suitability of the product for his or her use, and the user shall assume all legal, personal injury risk and liability and all other obligations, duties, and risks associated there with.

DISCLAIMER: NOT LEGAL FOR SALE OR USE IN CALIFORNIA ON ANY POLLUTION CONTROLLED MOTOR VEHICLE *Qualified Manufacturer Declared 49-State Federal Emissions Compliant Part for all 2015 to 2023 Indian Scout Models

SAFE INSTALLATION AND OPERATION RULES:

Before installing your new S&S part, it is your responsibility to read and follow the installation and maintenance procedures in these instructions and follow the basic rules below for your personal safety.

- Gasoline is extremely flammable and explosive under certain conditions and toxic when breathed. Do not smoke. Perform installation in a well ventilated area away from open flames or sparks.
- If motorcycle has been running, wait until engine and exhaust pipes have cooled down to avoid getting burned before performing any installation steps.
- Before performing any installation steps, disconnect battery to eliminate potential sparks and inadvertent engagement of starter while working on electrical components.
- Read instructions thoroughly and carefully so all procedures are completely understood before performing any installation steps. Contact S&S with any questions you may have if any steps are unclear or any abnormalities occur during installation or operation of motorcycle with an S&S part on it.
- Consult an appropriate service manual for your motorcycle for correct disassembly and reassembly procedures for any parts that need to be removed to facilitate installation.
- Use good judgment when performing installation and operating motorcycle. Good judgment begins with a clear head. Don't let alcohol, drugs or fatigue impair your judgment. Start installation when you are fresh.
- Be sure all federal, state and local laws are obeyed with the installation.
- For optimum performance and safety and to minimize potential damage to carb or other components, use all mounting hardware that is provided and follow all installation instructions.
- Motorcycle exhaust fumes are toxic and poisonous and must not be breathed. Run motorcycle in a well ventilated area where fumes can dissipate.

IMPORTANT NOTICE:

Statements in this instruction sheet preceded by the following words are of special significance.



WARNING

Means there is the possibility of injury to yourself or others.



CAUTION

Means there is the possibility of damage to the part or motorcycle.

NOTE

Other information of particular importance has been placed in italic type.

S&S recommends you take special notice of these items.

WARRANTY:

All S&S parts are guaranteed to the original purchaser to be free of manufacturing defects in materials and workmanship for a period of twelve (12) months from the date of purchase. Merchandise that fails to conform to these conditions will be repaired or replaced at S&S's option if the parts are returned to us by the purchaser within the 12 month warranty period or within 10 days thereafter.

In the event warranty service is required, the original purchaser must call or write S&S immediately with the problem. Some problems can be rectified by a telephone call and need no further course of action.

A part that is suspect of being defective must not be replaced by a Dealer without prior authorization from S&S. If it is deemed necessary for S&S to make an evaluation to determine whether the part was defective, a return authorization number must be obtained from S&S. The parts must be packaged properly so as to not cause further damage and be returned prepaid to S&S with a copy of the original invoice of purchase and a detailed letter outlining the nature of the problem, how the part was used and the circumstances at the time of failure. If after an evaluation has been made by S&S and the part was found to be defective, repair, replacement or refund will be granted.

ADDITIONAL WARRANTY PROVISIONS:

- (1) S&S shall have no obligation in the event an S&S part is modified by any other person or organization.
- (2) S&S shall have no obligation if an S&S part becomes defective in whole or in part as a result of improper installation, improper maintenance, improper use, abnormal operation, or any other misuse or mistreatment of the S&S part.
- (3) S&S shall not be liable for any consequential or incidental damages resulting from the failure of an S&S part, the breach of any warranties, the failure to deliver, delay in delivery, delivery in non-conforming condition, or for any other breach of contract or duty between S&S and a customer.

Tools Needed:

- Safety Glasses
- Cutting Tool/Utility Knife
- Flashlight
- Socket Set, Hex Bit, Metric
- Socket Set, Metric
- Socket Set, Torx® Bit
- Torque Wrench

Procedure:

NOTE - Please read the installation instructions thoroughly before beginning. Installation is easier if the vehicle is clean and free of debris. For your safety, and to ensure a satisfactory installation, perform all installation steps correctly in the sequence shown.

1. Support motorcycle securely in an upright position. Clamp front tire securely in a wheel vise.
2. Turn key or ignition switch to "OFF" position and remove key. If equipped with keyless fob, remove fob from proximity of vehicle.
3. Remove stock Muffler and Head Pipe from motorcycle as per service manual.
4. Retain four exhaust header nuts (A) and discard two gaskets (B).

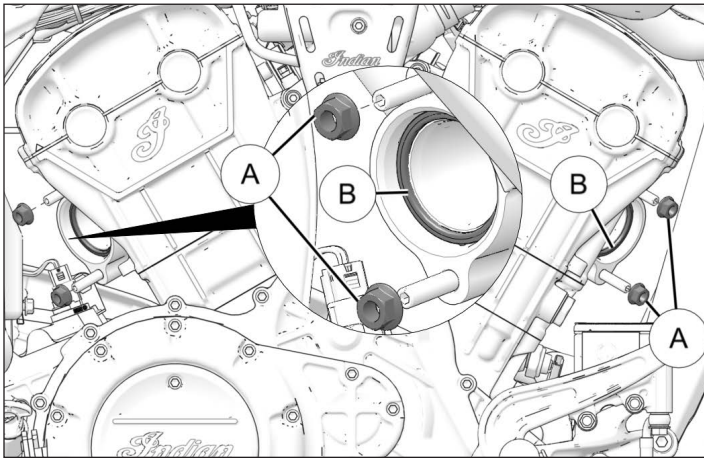

5. Make note of allocation of front and rear Oxygen Sensors. Carefully remove and retain front (C) and rear (D) Oxygen Sensors.

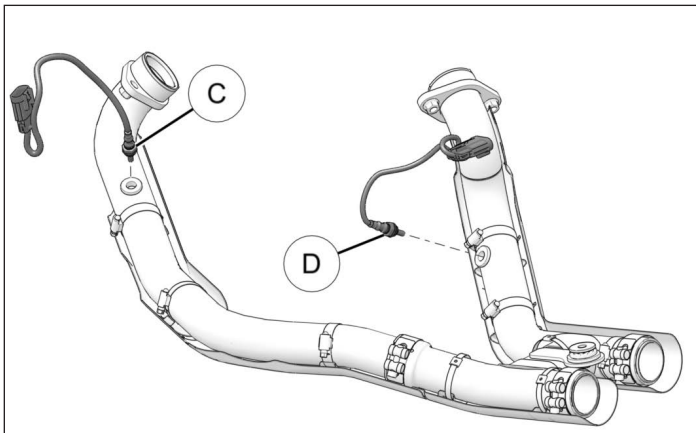

6. Remove and retain two screws (E), one nut (F) and one washer (G) from stock muffler mount (H). Remove stock muffler mount (H) and set aside.

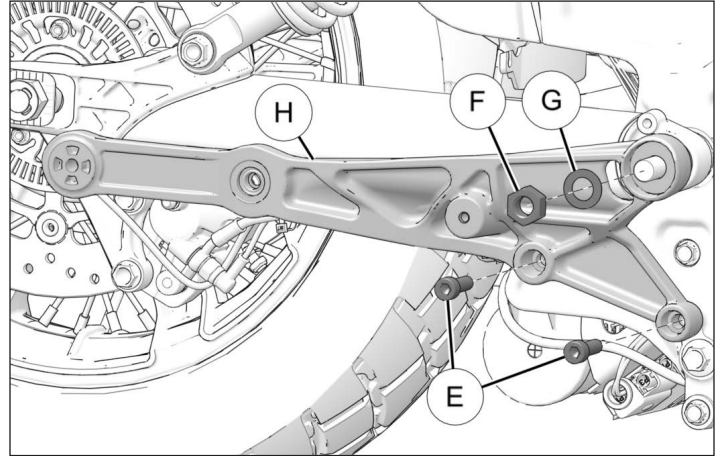

7. Remove and retain two washers (J), four rubber grommets (K) and two sleeve washers (L) from stock muffler mount (H).

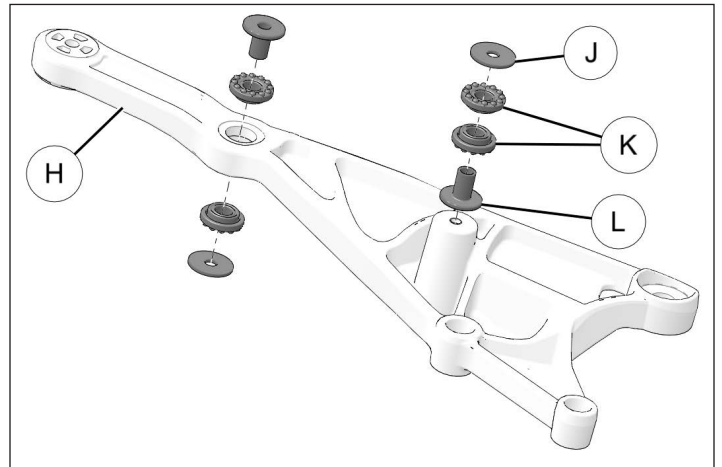

Mounting Bracket Installation

8. Install new Mounting Bracket (12) to frame using retained screws (E), nut (F), and washer (G). Torque fasteners to specification in service manual.

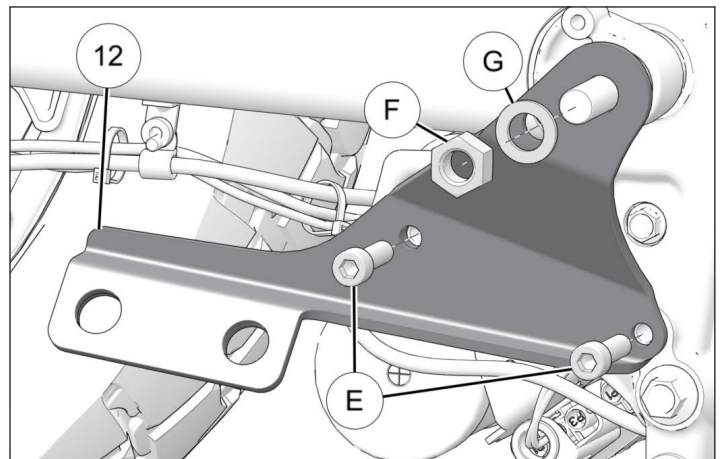

9. Install Swing Arm Cap (15) onto threaded end of exposed stud.

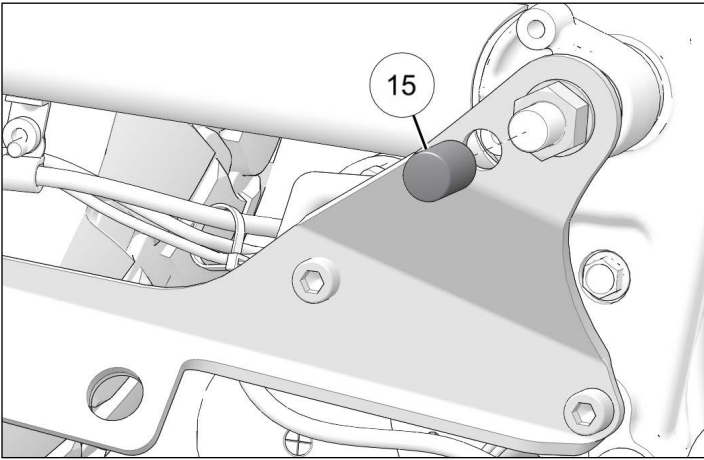

12. Loosely install front exhaust header (7) using two retained nuts (A). DO NOT tighten fasteners at this time. Ensure Oxygen Sensor wiring is routed back to connector.

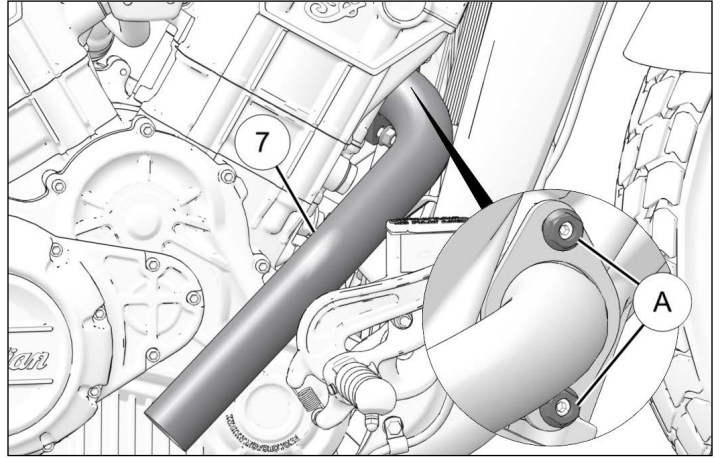

Exhaust Header Installation

10. Loosely install front (C) and rear (D) retained Oxygen Sensors into front (7) and rear (4) header pipes.

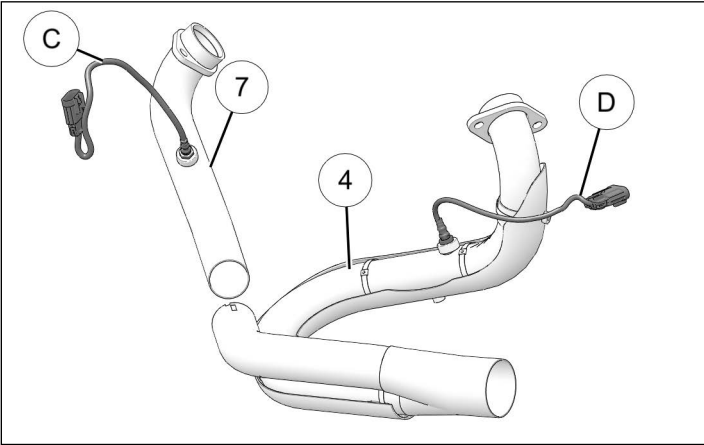

13. Slide clamp (8) onto rear header (4) with nut facing down and outward as shown. Insert front header pipe into rear header pipe opening and slide rear header into place. Loosely install rear exhaust header using two retained nuts (A). Ensure Oxygen Sensor wiring is routed back to connector.

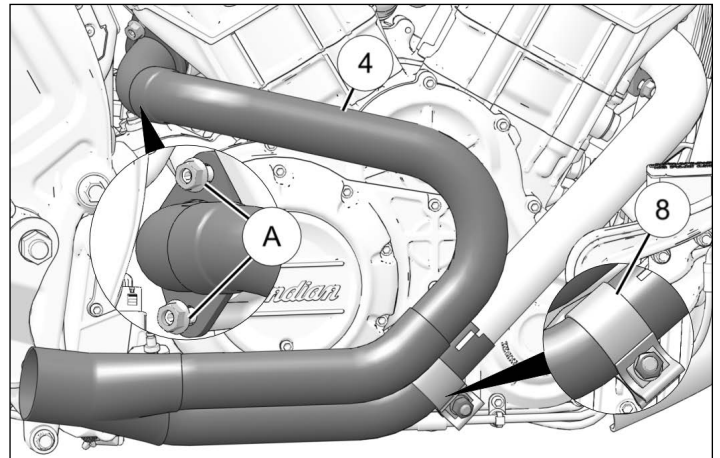

11. Install new exhaust header gaskets (14).

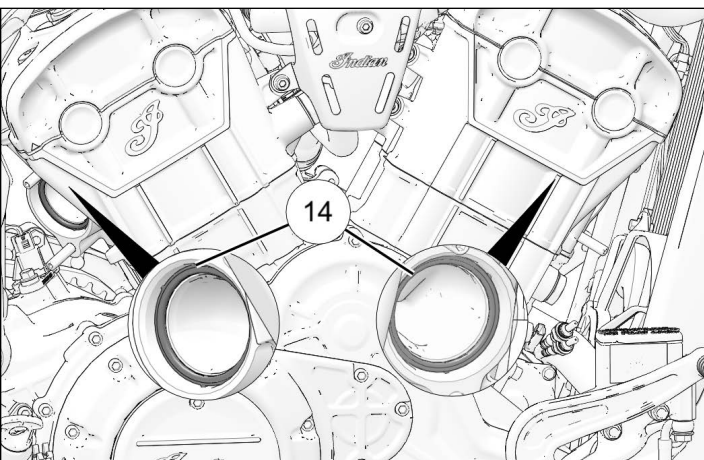

Muffler Installation

14. Stack two screws (13), two washers (J), and two rubber grommets (K). Set these aside for now. Stack two rubber grommets (K) and two sleeves (L) and install through mounting bracket (12) on the side which will contact the muffler.

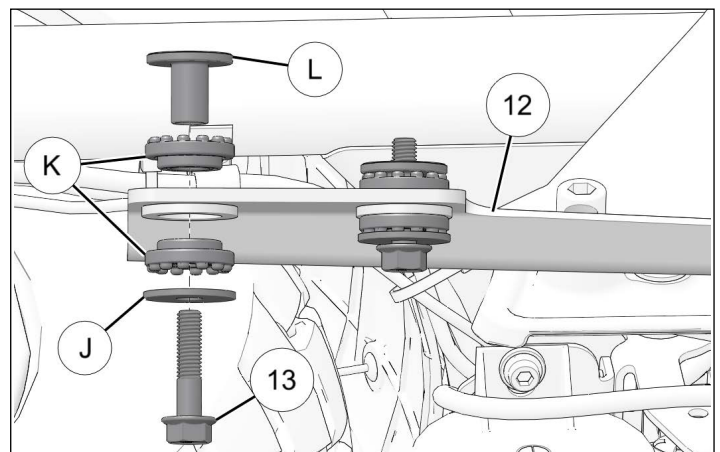

15. Slide muffler clamp ② onto muffler assembly ① and slide muffler assembly ① onto rear header ④ .

DO NOT tighten clamp at this time.

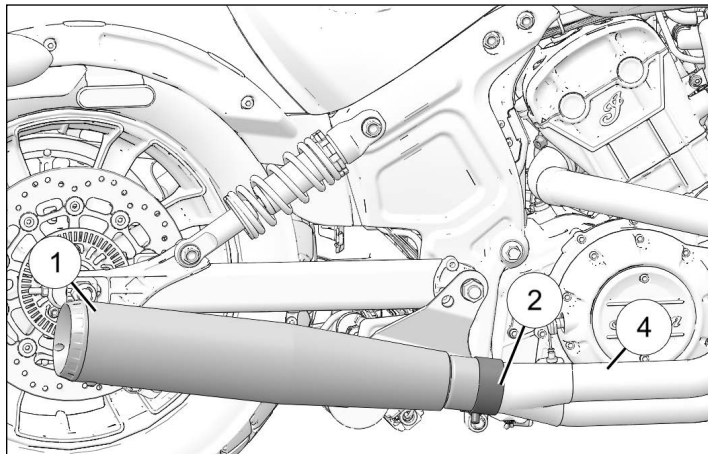

16. Align muffler assembly, install stacks set aside in step 14 through the back of mounting bracket ⑫ into threaded holes in muffler ①. Adjust header components as needed to allow parts to fit together with minimal stress and binding. Rotate muffler clamp ② away from ground and torque clamp ② and mounting bracket screws ⑬ to specifications.

Torque Specifications

Muffler Clamp ② : 40 ft-lbs (54 N·m)

Torque Specifications

Mounting Bracket Screws ⑬ : 18 ft-lbs (24 N·m)

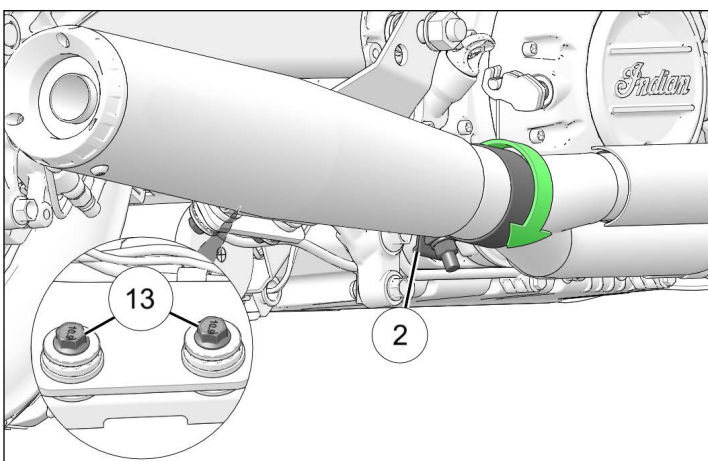

17. Snug down (DO NOT torque) front ⑦ and rear ④ exhaust header nuts in order:

- ① Rear Lower
- ② Front Lower
- ③ Rear Upper
- ④ Front Upper

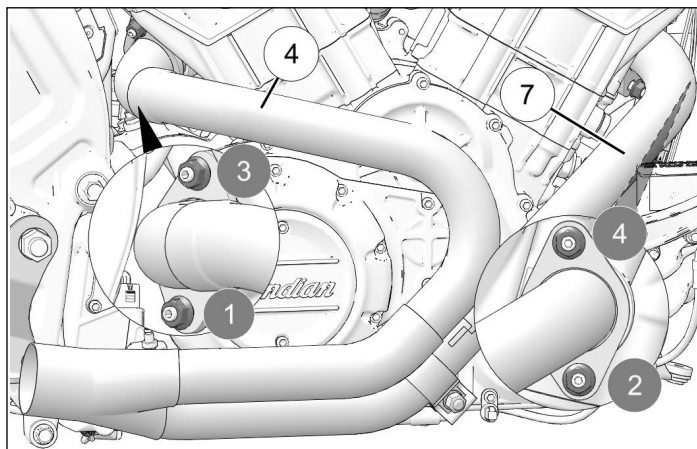

18. Torque exhaust header nuts to specification in same order as previous step.

Torque Specifications

Exhaust Header Nuts: 12 ft-lbs (16 N·m)

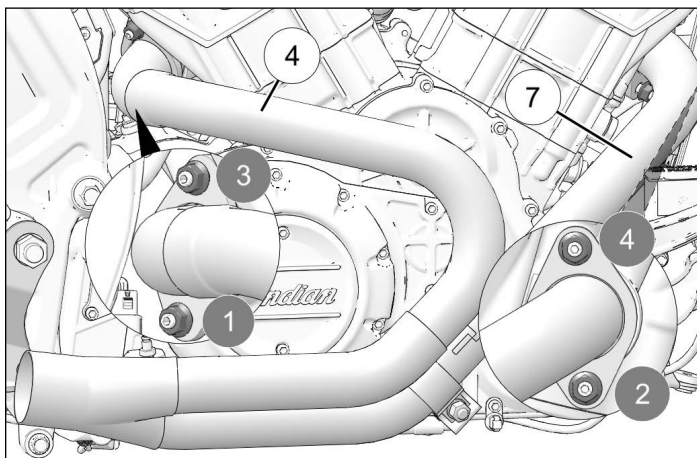

19. Torque clamp ⑧ to specification.

Torque Specifications

Muffler Clamp ⑧ : 40 ft-lbs (54 N·m)

20. Torque Oxygen Sensors to specification.

Torque Specifications

Oxygen Sensors: 14 ft-lbs (19 N·m)

Heat Shield Installation

21. Open up and Insert clamp ③ into slot on collector heat shield ⑨ in orientation shown.

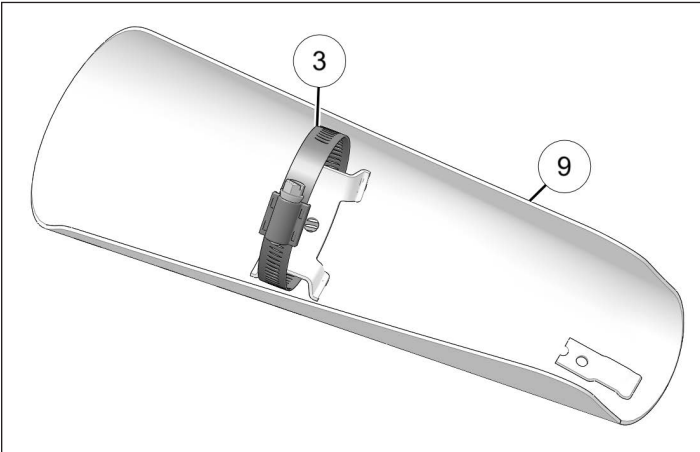

22. Install collector heat shield ⑨ by first inserting tab (shown with inset) under rear edge of installed heat shield, then securing with clamp ③. Torque clamp screw to specification.

Torque Specifications

Exhaust Clamp ③: 27 in-lbs (3 N·m)

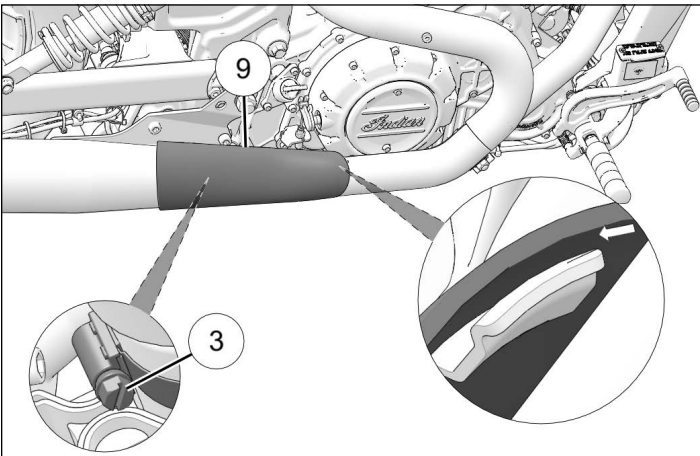

23. Insert three clamps ⑥ into slots on front lower heat shield ⑤ in orientation shown.

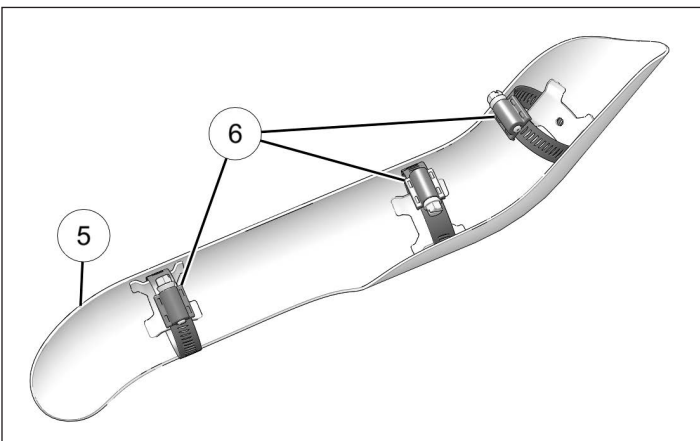

24. Install lower front heat shield ⑤ in place and secure with three clamps ⑥. Torque clamps to specification.

Torque Specifications

Exhaust Clamp ⑥: 27 in-lbs (3 N·m)

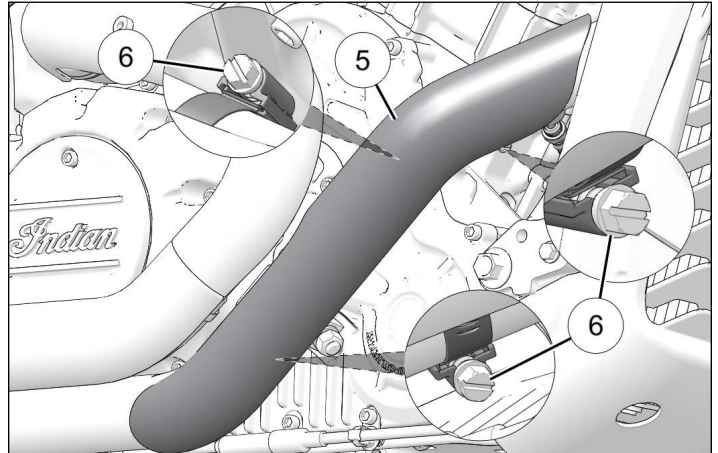

NOTE: The clamps on the rear heat shield are not removable. Replacement of the heat shield requires the purchase of a new header that includes the heat shield.