

BMW Motorrad

Workshop installation instructions

Luggage carrier for topcase

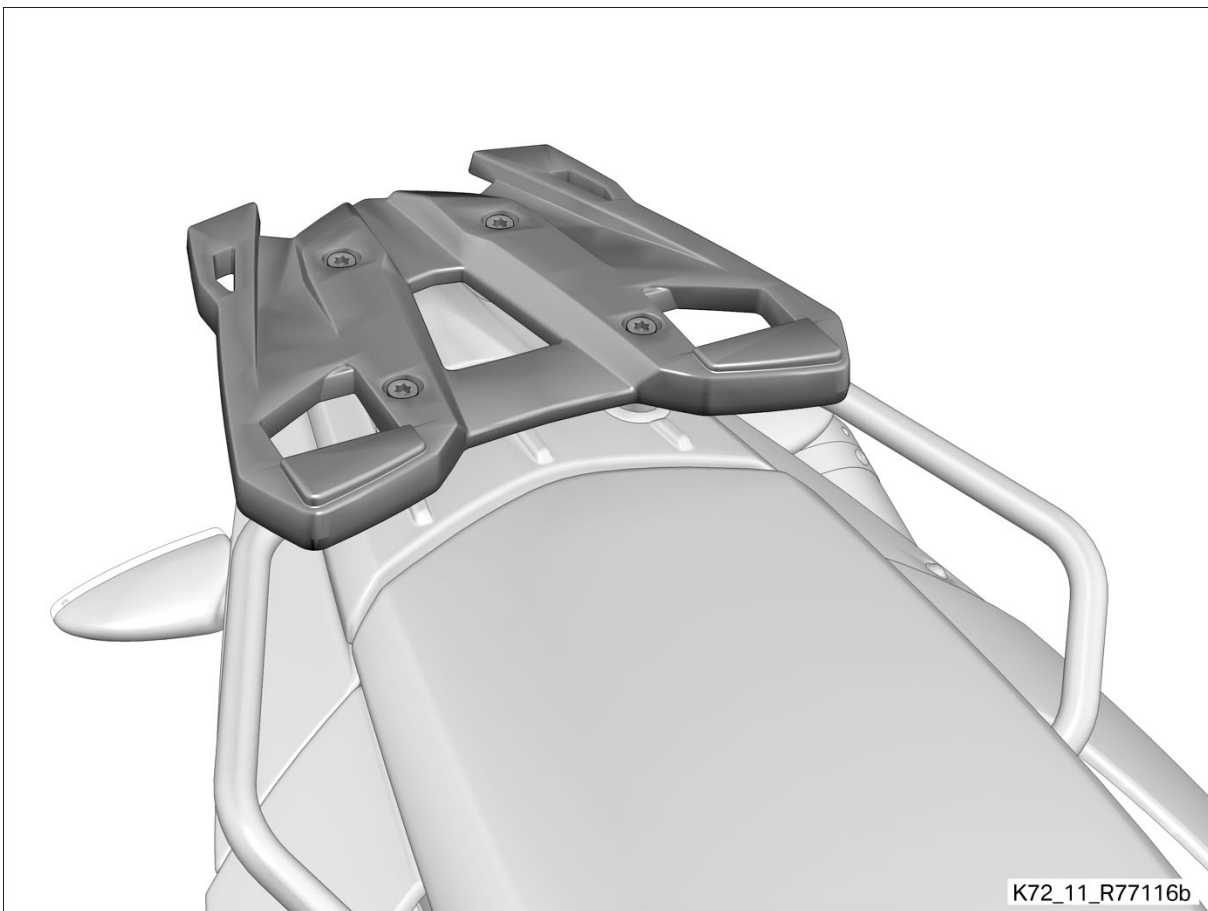

Before commencing work, you must read these installation instructions through carefully and make sure you understand them fully.

BMW Motorrad recommends having this installation kit installed by a specialist workshop with the requisite special tools, preferably an authorised BMW Motorrad dealer.

Incorrect installation and incorrect handling give rise to considerable safety risks.

The symbols used to draw attention to safety instructions in this manual are as follows:



Warning

This symbol stands for precautions and measures which are essential in order to protect the rider and other persons from possibly severe or fatal injury.



Attention

Specific instructions and safety precautions intended to prevent damage to the motorcycle and accessories. Non-compliance can void the warranty.



Note

Specific instructions on how to operate, control, adjust or look after items of equipment on the motorcycle.



Tightening torque

Screws, bolts and nuts are tightened in accordance with the applicable DIN/ISO standards. Tightening torques that deviate from the standards are stated. Non-compliance can result in damage to the motorcycle or accessories or can endanger the rider.

▶ Start of the main activity

▷ Start of the secondary activity

• Instruction

◀ End of the main activity

< End of the secondary activity

◇ End of validity designation CS (construction status), OE (optional extra) or OA (optional accessory)

©2013 Bayerische Motoren Werke Aktiengesellschaft
80788 Munich, Germany

Reprinting, even only in extracts, is only permitted with written authorization by BMW Motorrad, Aftersales.

Printed in Germany.

Subject to change without notice. Errors and omissions excepted.

All rights reserved.

Luggage carrier for topcase

Requisite tools

- Torx bit

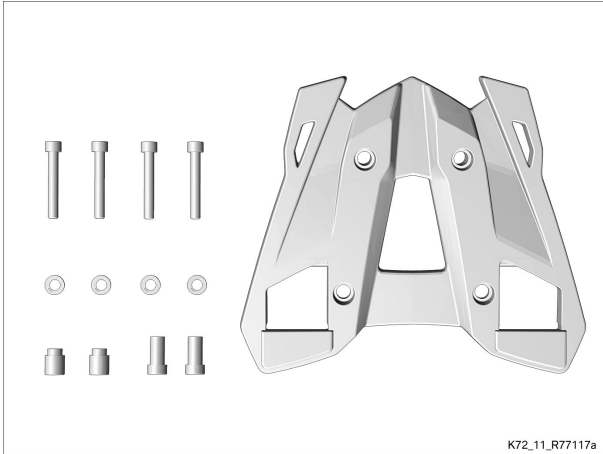

Scope of supply

- Luggage rack 4 of
- Screw, M8 x 55 4 of
- Washer 4 of
- Spacing sleeve, front 2 of
- Spacing sleeve, rear 2 of

Also required:

 Thread-locking compound	
Loctite 243, Medium strength	83 19 2 210 339

General instructions

Attention

A motorcycle that has not been stood up correctly may topple over when the following work is being carried out. Make sure that the motorcycle is standing up safely.

77 44 047 Installing luggage carrier for topcase

Additional work: 46 52 511 Removing and installing the middle stand special tool (motorcycles without centre stand)

1

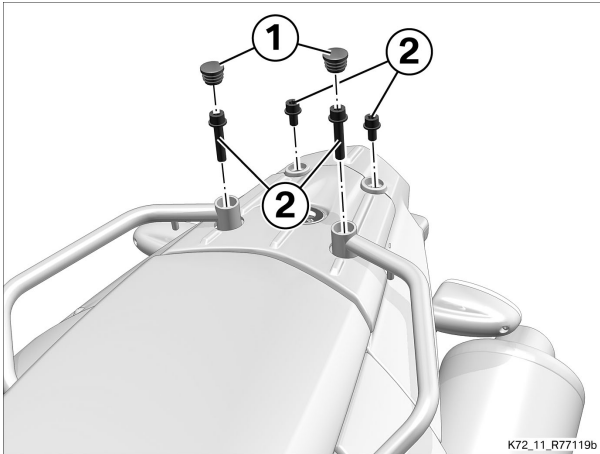

► Removing screws for grab handles and number-plate carrier

- Remove plugs (1).
- Remove screws (2).

2

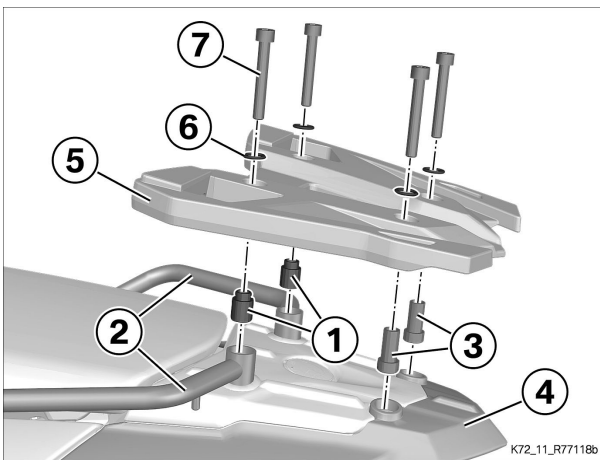

► Installing luggage carrier for topcase

- Insert front spacing sleeves (1) into grab handles (2).
- Insert rear spacing sleeves (3) into number-plate carrier (4).
- Position luggage carrier for topcase (5) on the spacing sleeves.
- Clean the threads.
- Apply thread-locking compound to screws (7).



Thread-locking compound

Loctite 243, Medium strength

83 19 2 210 339

- Install washers (6) with screws (7).



Tightening torques

Luggage carrier for topcase to grab handle and number-plate carrier

M8 x 55

19 Nm

Thread-locking compound (Loctite 243, Medium strength)

► **Final check of work performed**

- Check that
 - the work as performed achieved the intended purpose.
 - all reservoirs and containers have been filled and that all fluids and lubricants are at their correct levels.
 - all threaded fasteners released beforehand have been correctly retightened.
 - the fuel system is free of leaks.
 - the lights and signalling equipment are fully operational and that the motorcycle is roadworthy.
 - the brake pads of the front and rear brakes are bedded against the brake discs.

