

HYDRAULIC PLOW ACTUATOR BRACKETS

Plow Accessory

PART #106305

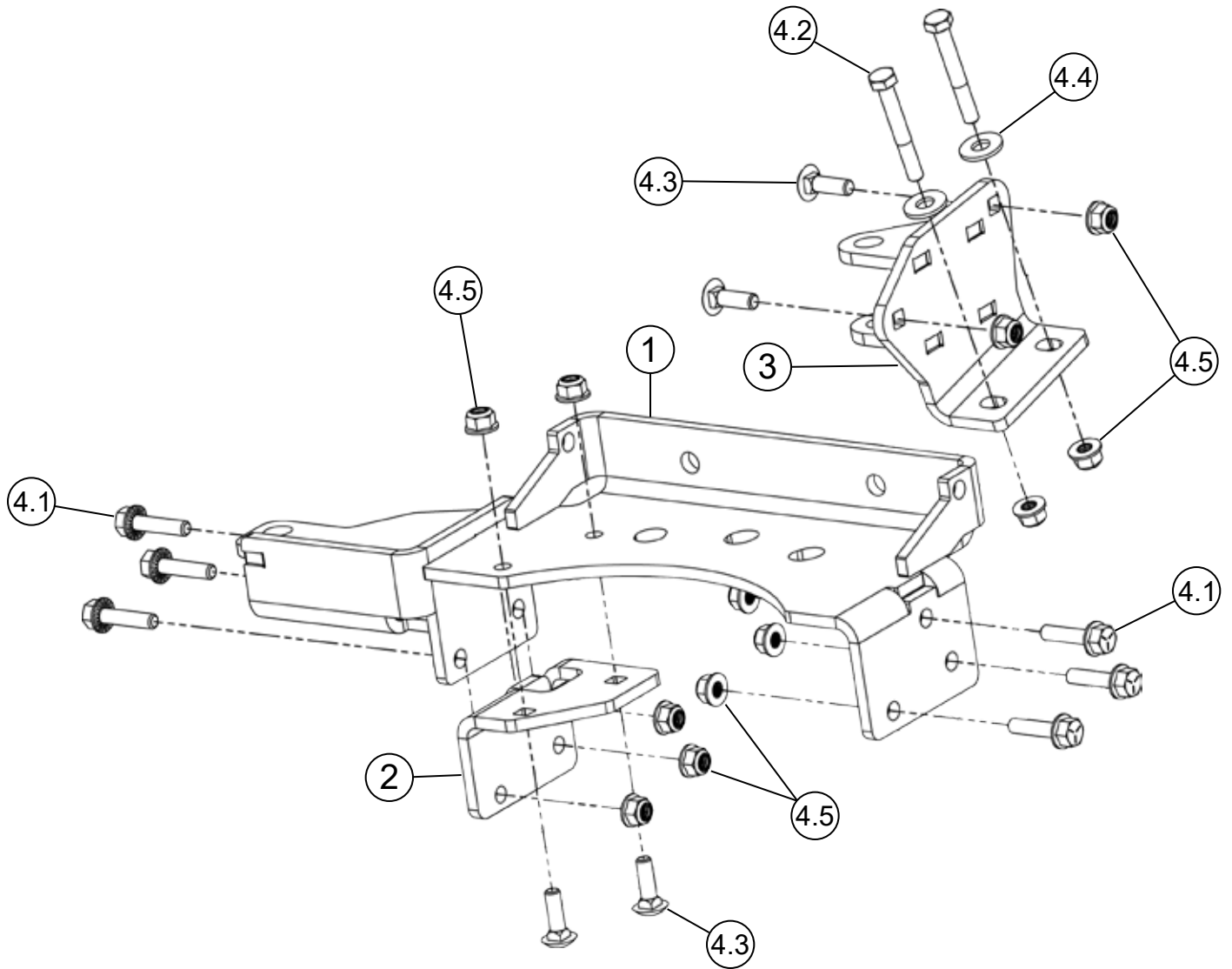

Item #	Qty.	Description
1	1	Cradle Bracket
2	1	Inner Cradle Bracket
3	1	Rear Tube Bracket
4	1	Hardware Kit (HK-404)

Item #	Qty.	Description
4.1	6	5/16"-18 X 1.25 Hex Flange Bolt GR 8
4.2	2	5/16"-18 X 2.25 Hex Bolts GR 5
4.3	4	5/16"-18 X 1.00 Carriage Bolts GR5
4.4	2	5/16" Flat Washer
4.5	12	5/16"-18 Hex Flange Lock Nut



BRACKET INSTALLATION INSTRUCTIONS

Note: Make sure all hardware needed to complete this mount is in the package. Thoroughly read through and understand the instructions before installing.

1. Remove springs from cradle

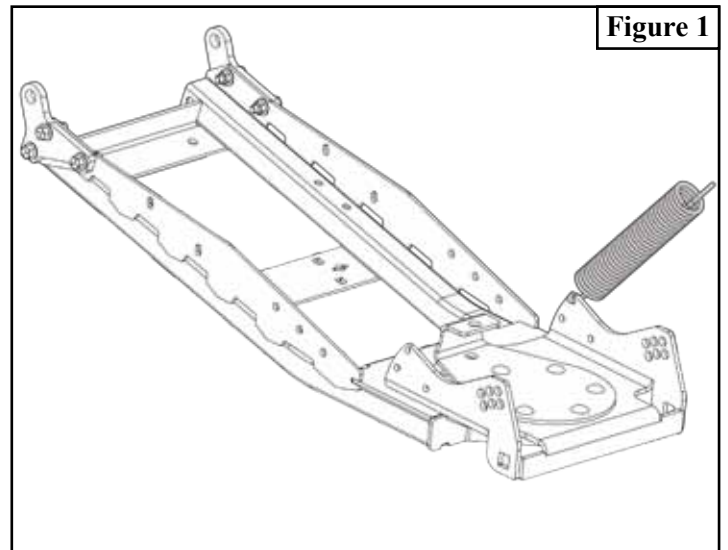

2. Pull up on the lift latch handle (A), compressing spring (B). Remove the E-retaining clip (D) located under washer (C) as shown in Figure 2. Items (A,B,C, and D) can be discarded as they will not be reused.

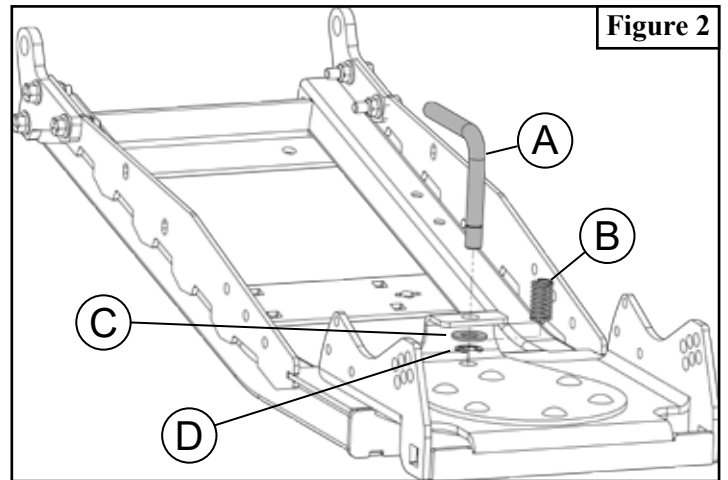

3. Attach rear tube bracket (3) to the push tube using bolts (4.2 & 4.3) and nuts (4.5). Place bolts (4.2) through washers (4.4) before placing through the push tubes. As shown in figure 3.

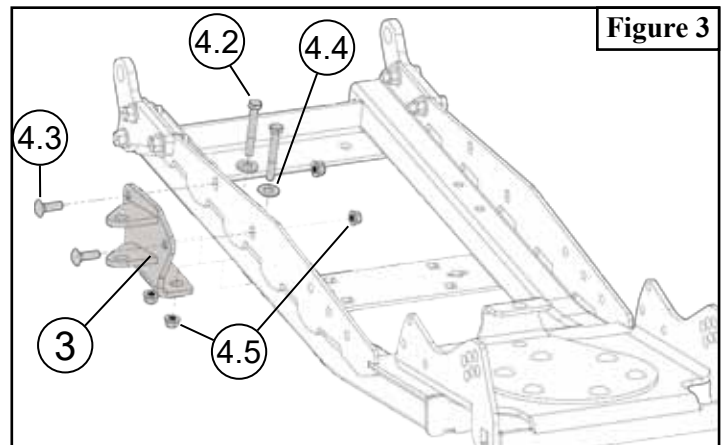

BRACKET INSTALLATION INSTRUCTIONS

4. Loosely assemble inner cradle bracket (2) to the cradle bracket (1), using carriage bolts (4.3) and lock nuts (4.5), as shown in Figure 4.
5. Place cradle bracket (1) over the push tube cradle and attach with bolts (4.1) and lock nuts (4.5), as shown in Figure 4.
6. Tighten all hardware evenly.

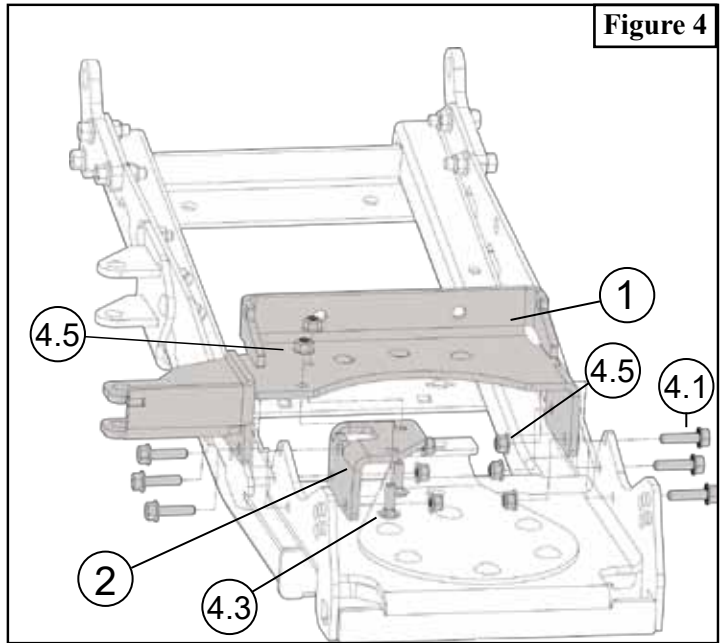

7. Springs will attach to the bent flange on the front cradle bracket (1). As shown in Figure 5.

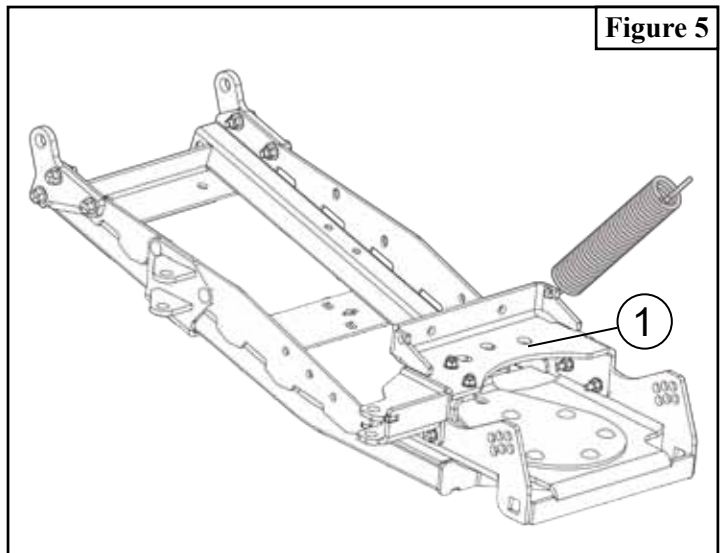

ACTUATOR INSTALLATION INSTRUCTIONS

Note: Actuator is not included with this kit. Items below come with kit #ACT203

Item #	Qty.	Description
5	1	Actuator
6	1	Hardware Kit
6.1	2	M14-2.00 X 80 Hex Bolts GR8.8
6.2	12	M14 Flat Washer
6.3	2	M14 X 2.00 Hex Lock Nut

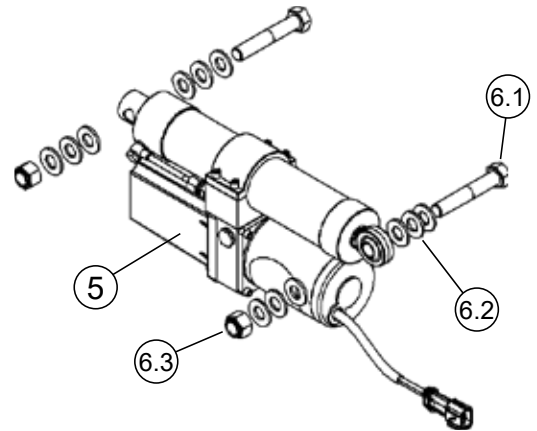

INSTALLATION INSTRUCTIONS

1. Place bolt (6.1) through flat washer (6.2), top tab of rear actuator bracket, flat washer (6.2), Hydraulic Actuator (5), flat washer (6.2), bottom tab of rear actuator bracket, and flat washer (6.2). Place nylock nut (6.3) onto bolt (6.1) as shown in Figure 6. (This orientation of hardware is just a guideline)

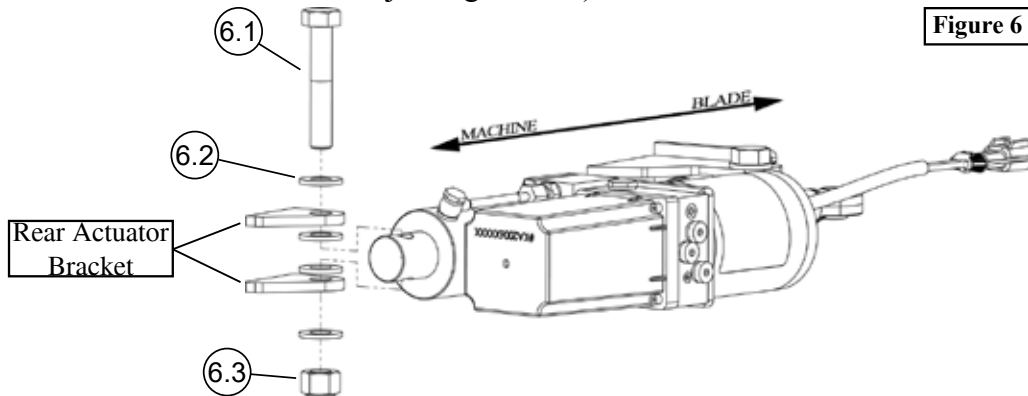

Figure 6

2. Repeat previous step for mounting the front half of the actuator, as shown in Figure 7. It is most important that you use the washers to make sure that the actuator is parallel to the cradle swivel point, as shown in Figure 8. Both front, and rear bolts should not be tight, thread the nut on until Nylock is engaged.

Note: Periodically apply lubricant to actuator attachment points.

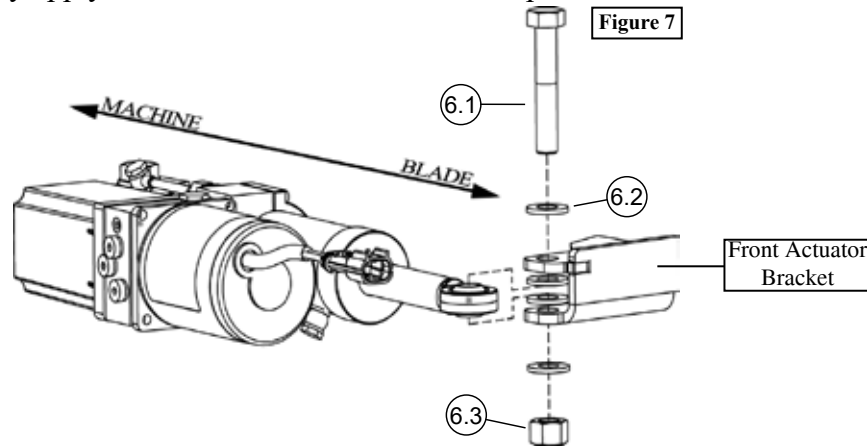

Figure 7

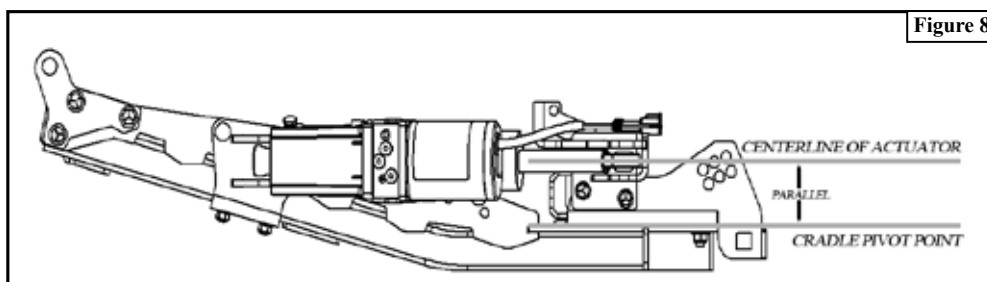

Figure 8