

POWER COMMANDER 6

Install guide for: PC6-22066

Model coverage: 2015-2018 Yamaha SR400

PARTS LIST

×

- | | | | |
|---|--------------------|---|------------------------|
| 1 | POWER COMMANDER 6 | 2 | POWER COMMANDER DECALS |
| 1 | INSTALLATION GUIDE | 2 | VELCRO STRIPS |
| 1 | USB CABLE | 1 | ALCOHOL SWAB |
| 2 | DYNOJET DECALS | 1 | ZIP TIE |

**PLEASE READ ALL DIRECTIONS BEFORE STARTING INSTALLATION.
THE IGNITION MUST BE TURNED OFF BEFORE INSTALLATION.**

×

 IPC6-22066.01

YAMAHA

INPUT ACCESSORY GUIDE

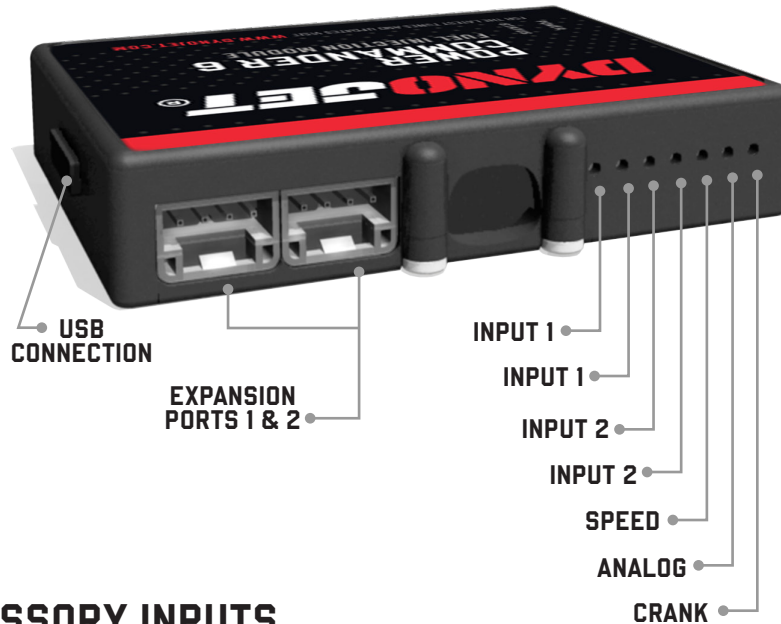

OPTIONAL ACCESSORY INPUTS

- Map** (Input 1 or 2) The PC6 has the ability to hold 2 different base maps. You can switch on the fly between these two base maps when you hook up a switch to the MAP inputs. You can use any open/close type switch. The polarity of the wires is not important.
- Shifter** (Input 1 or 2) Used for clutch-less full throttle upshifts. Insert the wires from the Dynojet quick shifter into either Input 1 or Input 2. The polarity of the wires is not important. Set to Input 2 by default.
- Speed** If your application has a speed sensor then you can tap into the signal side of the sensor and run a wire into this input. This will allow you to calculate gear position in the Control Center Software. Once gear position is setup you can alter your map based on gear position and setup gear dependent kill times when using a quickshifter. .
- Analog** This input is for a 0-5v signal such as engine temp, boost, etc. Once this input is established you can alter your fuel curve based on this input in the Power Core software.
- Launch** You can connect a wire to either Input 1 or Input 2 and then the other end to a switch. This switch when engaged (continuity) will only allow the RPM to be raised to a certain limit (set in the software). When released, you will have full RPM.

WIRE CONNECTIONS

To input wires into the PC6 first remove the rubber plug on the backside of the unit and loosen the screw for the corresponding input. Using a 22-24 gauge wire, strip about 10mm from its end. Push the wire into the hole of the PC6 until it stops and then tighten the screw. Make sure to reinstall the rubber plug.

NOTE: If you tin the wires with solder it will make inserting them easier.

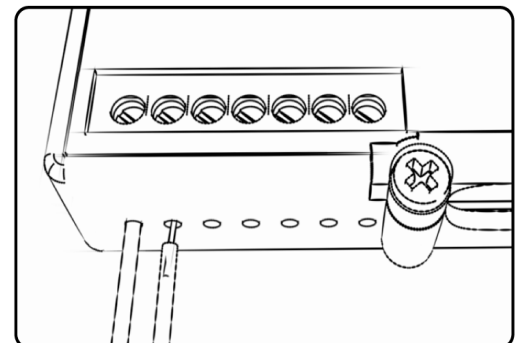

INSTALLING THE POWER COMMANDER 6

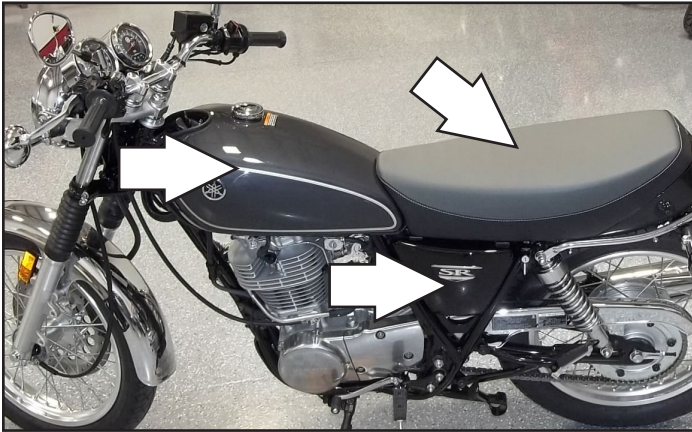

REMOVE BODYWORK

- 1 Remove the seat.

There are 2 bolts going through the frame rails below the seat on both sides.

- 2 Remove the left side cover.

Use the bike's key to unlock this side cover. The key latch is just forward of the side cover.

- 3 Remove the fuel tank.

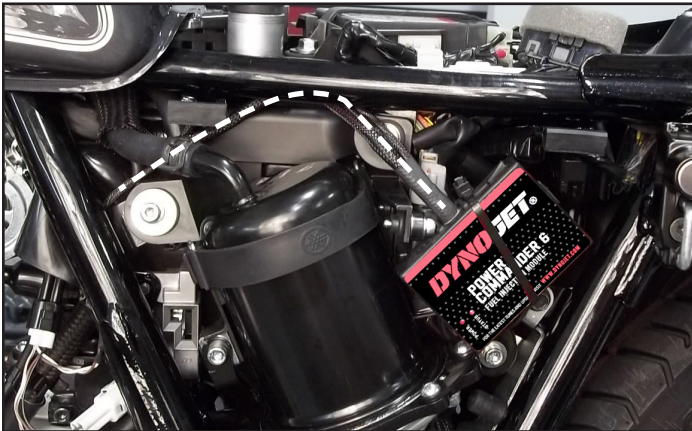

INSTALL PC6

- 4 Using the supplied zip-tie, secure the PC6 module behind the left side cover just rear of the fuel pump.

- 5 Route the PC6 wiring harness.

Route the wiring harness branch with the pair of WHITE 3-pin connectors under frame rail and towards the stock electrical connector bundle inside of the BLACK rubber boot located just rear of the engine on the left side of the bike.

Route the main wiring harness branch with several connectors under the upper frame rail towards the throttle body. Then route the wires with spade connectors out to the left side of the bike and forward alongside the stock wiring harness to the bike's ignition coil.

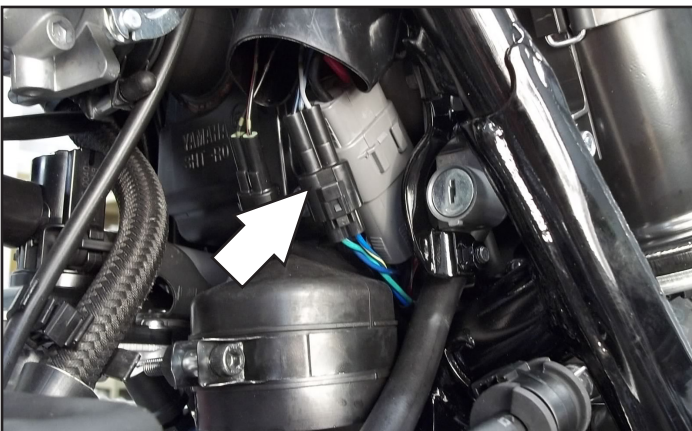

UNPLUG CPS

- 6 Inside of the BLACK rubber boot on the left side of the bike, locate and unplug the stock Crank Position Sensor connectors.

This is a pair of BLACK 3-pin connectors.

INSTALLING THE POWER COMMANDER 6

- 7 Plug the pair of WHITE 3-pin connectors of the PC6 in-line of the stock Crank Position Sensor connectors.

Tuck all of the connectors in this location back into the stock rubber boot.

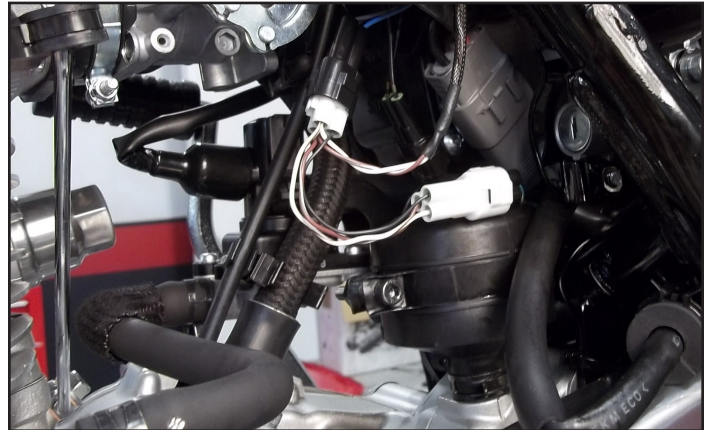

CONNECT TO CPS

- 8 At the top of the throttle body unplug the Fuel Injector,

This is a GREY 2-pin connector.

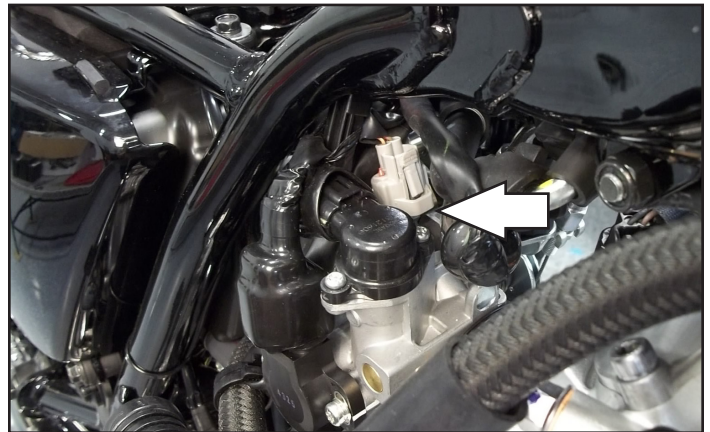

UNPLUG INJECTOR

- 9 Plug the pair of 2-pin connectors on the PC6 wiring harness in-line of the Fuel Injector and the stock wiring harness.

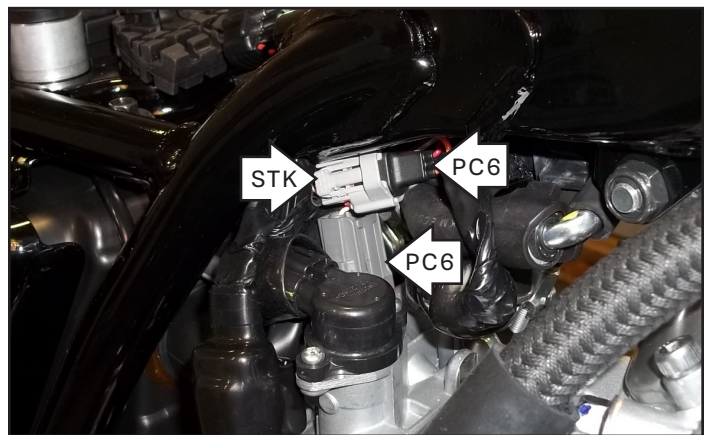

CONNECT TO INJECTOR

INSTALLING THE POWER COMMANDER 6

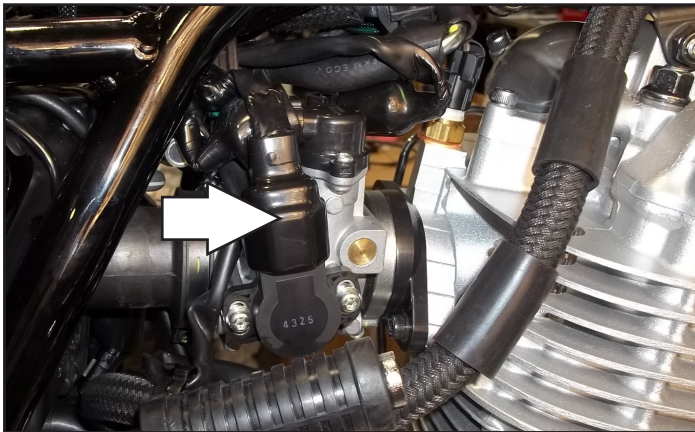

UNPLUG TPS

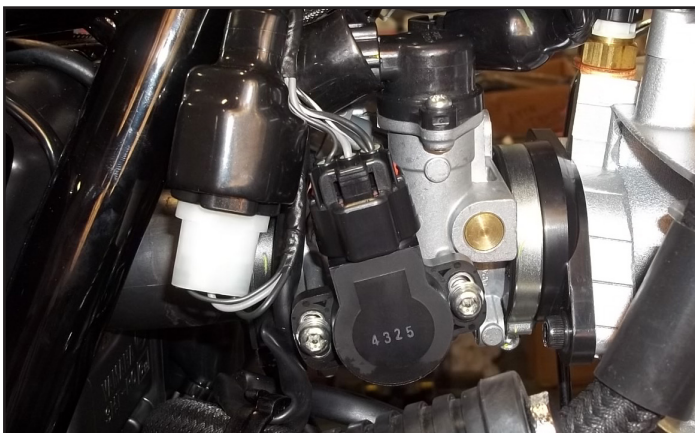

CONNECT TO TPS

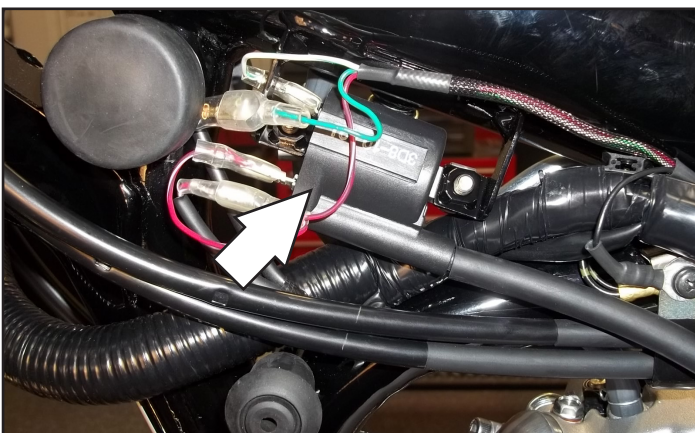

CONNECT TO IGNITION COIL

- 10 Unplug the stock BLACK 3-pin connector from the bike's Throttle Position Sensor on the right hand side of the throttle body.
- 11 Plug the PC6 wiring harness in-line of the bike's Throttle Position Sensor and stock wiring harness.
- 12 Unplug the stock ORANGE wire from the Ignition Coil.
- 13 Unplug the stock RED/WHITE wire from the Ignition Coil.
- 14 Plug the stock ORANGE wire to the PC6 GREEN wire.
- 15 Plug the PC6 WHITE/GREEN wire to the upper tab on the Ignition Coil.
- 16 Plug the RED/WHITE PC6 wires in-line of the stock RED/WHITE wire and the lower tab on the Ignition Coil.

The Ignition Coil is located on the left side of the frame near the steering stem.

Be sure to slide the insulators over any exposed metal at all of these connections.

- 17 Secure the PC6 ground wire with the small ring lug to the common ground used for the throttle cable holder on the left side of the frame.
- 18 Reinstall the fuel tank, left side cover, and the seat.
- 19 Affix the supplied CARB E.O. label to a conspicuous area. Next to the original emissions label is a good location. Make sure to clean the surface before attaching.

Optional inputs:

Speed - WHITE wire in the headlight shell (front wheel speed)

12v source for Auto-tune - BLUE wire of the tail light connector under the seat.

To see a video demonstration of this install visit our channel (DynojetResearch) on YouTube.com



PUSH THE LIMIT

2191 MENDENHALL DRIVE, NORTH LAS VEGAS, NV 89081 - 800-992-4993 - DYNOJET.COM

© 2007-2020 DYNOJET RESEARCH ALL RIGHTS RESERVED