

[POWER COMMANDER V]

2020 Suzuki Katana

Installation Instructions



PARTS LIST

- 1 Power Commander
- 1 USB Cable
- 1 Installation Guide
- 2 Power Commander Decals
- 2 Dynojet Decals
- 2 Velcro strips
- 1 Alcohol swab

THE IGNITION MUST BE TURNED OFF BEFORE INSTALLATION!

THE LATEST POWER COMMANDER SOFTWARE AND MAP FILES CAN BE DOWNLOADED FROM OUR WEB SITE AT:
www.powercommander.com

PLEASE READ ALL DIRECTIONS BEFORE STARTING INSTALLATION

Dynojet

2191 Mendenhall Drive North Las Vegas, NV 89081 (800) 992-4993 www.powercommander.com

POWER COMMANDER V INPUT ACCESSORY GUIDE

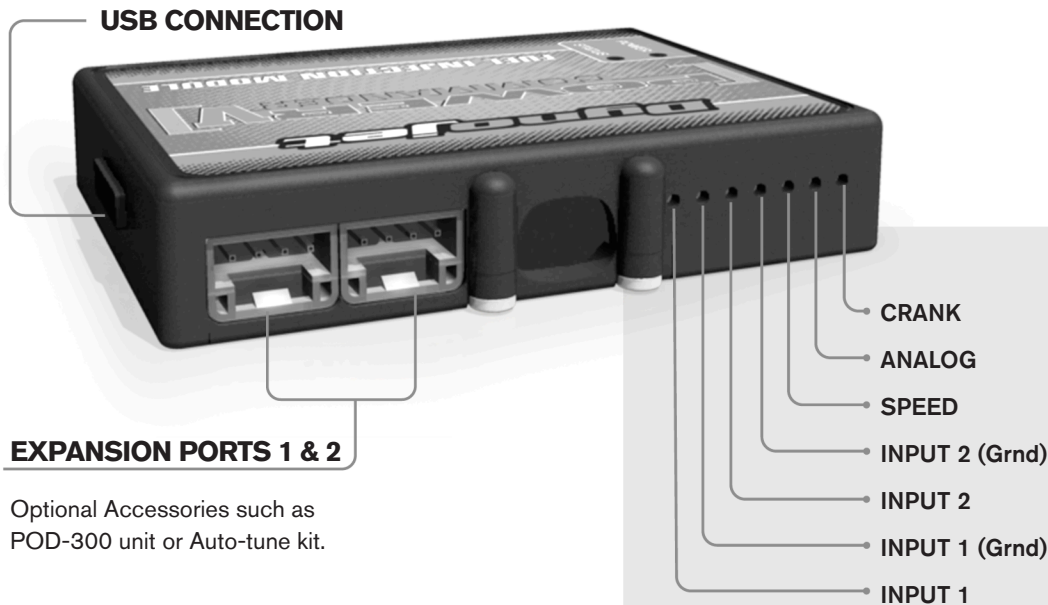

Wire connections:

To input wires into the PCV first remove the rubber plug on the backside of the unit and loosen the screw for the corresponding input. Using a 22-24 gauge wire strip about 10mm from its end. Push the wire into the hole of the PCV until it stops and then tighten the screw. Make sure to reinstall the rubber plug.

NOTE: If you tin the wires with solder it will make inserting them easier.

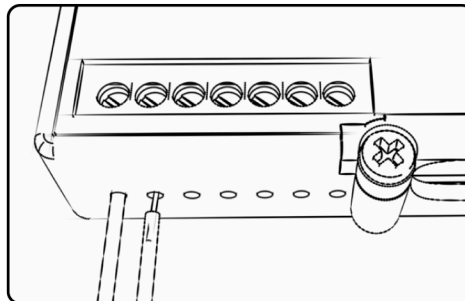

ACCESSORY INPUTS

Map -

(Input 1 or 2) The PCV has the ability to hold 2 different base maps. You can switch on the fly between these two base maps when you hook up a switch to the MAP inputs. You can use any open/close type switch. The polarity of the wires is not important. When using the Autotune kit one position will hold a base map and the other position will let you activate the learning mode. When the switch is "CLOSED" Autotune will be activated. (Set to Switch Input #1 by default.)

Shifter-

(Input 1 or 2) These inputs are for use with the Dynojet quickshifter. Insert the wires from the Dynojet quickshifter into the SHIFTER inputs. The polarity of the wires is not important. (Set to Switch Input #2 by default.)

Speed-

If your application has a speed sensor then you can tap into the signal side of the sensor and run a wire into this input. This will allow you to calculate gear position in the Control Center Software. Once gear position is setup you can alter your map based on gear position and setup gear dependent kill times when using a quickshifter.

Analog-

This input is for a 0-5v signal such as engine temp, boost, etc. Once this input is established you can alter your fuel curve based on this input in the control center software.

Crank-

Do **NOT** connect anything to this port unless instructed to do so by Dynojet. It is used to transfer crank trigger data from one module to another.

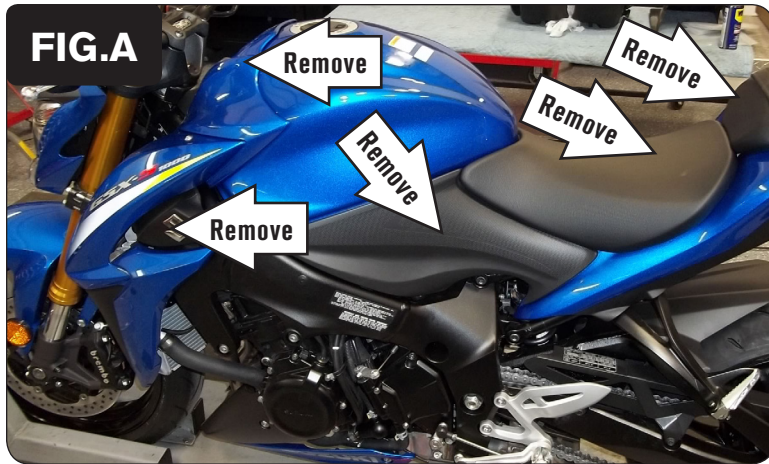

- 1 Remove both seats. Remove the side panels on both sides of the bike. Remove the radiator shroud panels on both sides of the bike. Remove the panel at the front of the fuel tank and the panel over the key switch (Fig. A).
- 2 Remove the bike's battery.
- 3 Remove the 2 bolts at the front of the fuel tank. Lift and prop the fuel tank.



- 4 Use the supplied Velcro to secure the PCV module in the tail section beneath the passenger seat (Fig. B).

Clean both surfaces with the supplied alcohol swab prior to attaching the Velcro.

- 5 Route the PCV wiring harness forward towards the engine along the left side frame rail.

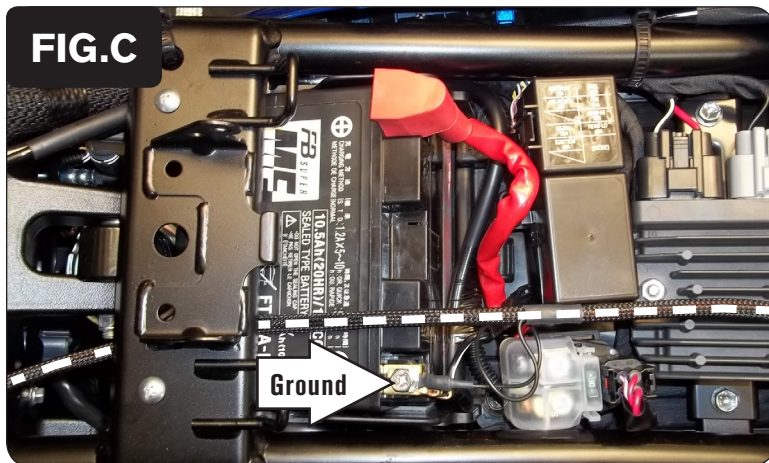

- 6 Route the wiring harness through the left side of the battery box.
- 7 Reinstall the battery. Secure the PCV ground wire with the small ring lug to the negative (-) battery post (Fig. C).

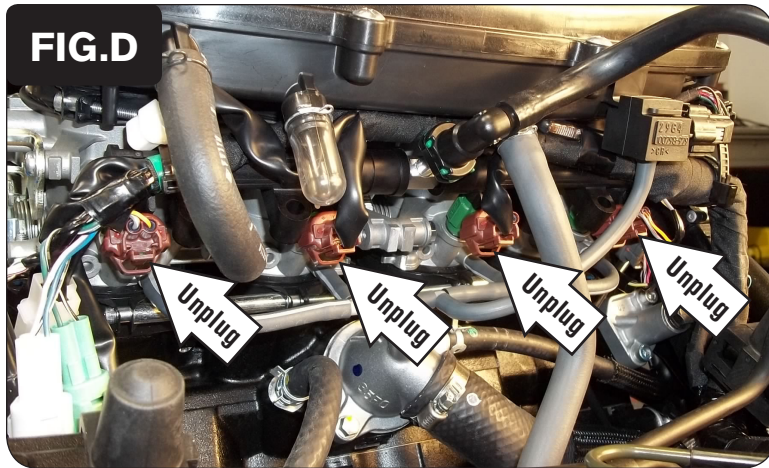

- 8 Unplug all 4 of the fuel injectors (Fig. D).

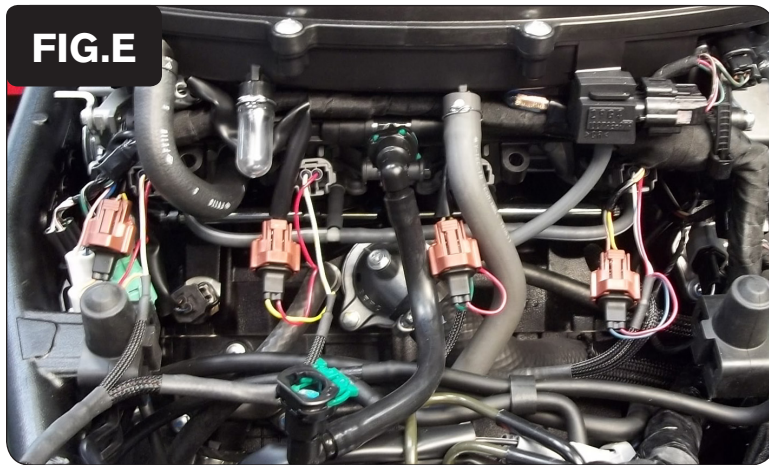

- 9 Plug the PCV wiring harness in-line of each fuel injector and the stock wiring harness (Fig. E).

PCV leads with ORANGE colored wires go to the #1 injector (left most).

PCV leads with YELLOW colored wires go to the #2 injector.

PCV leads with GREEN colored wires go to the #3 injector.

PCV leads with BLUE colored wires go to the #4 injector (right most).

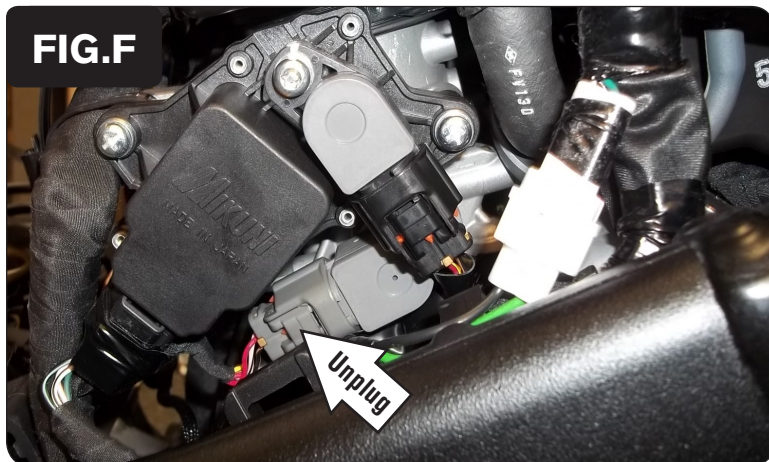

- 10 Unplug the lower primary Throttle Position Sensor connector with the GREY connector (Fig. F).

The TPS is located on the right side of the throttle bodies.

Do NOT unplug the upper secondary TPS connector with the BLACK connector.

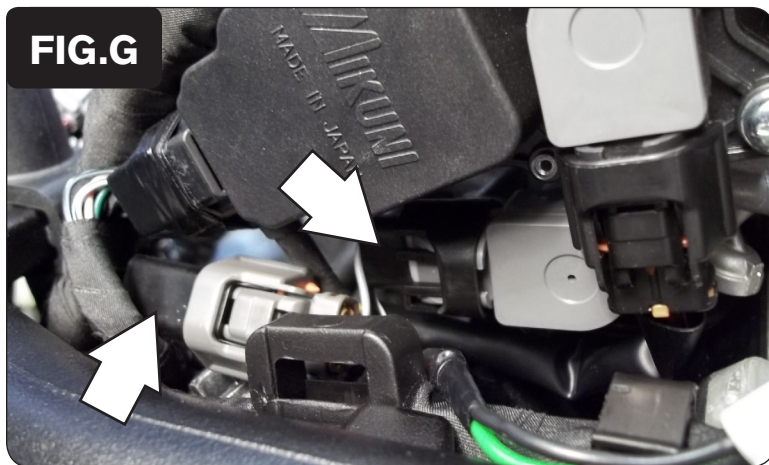

- 11 Plug the pair of 3-pin PCV connectors in-line of the TPS and the stock wiring harness (Fig. G).
- 12 Lower and re-secure the fuel tank. Reinstall all of the removed bodywork and the seats.

Optional Inputs:

Analog Gear - PINK wire of the Gear Position Sensor located below the countershaft sprocket

Engine Temp - BLACK/BLUE wire of coolant temp sensor located under the throttle bodies on the left side of the engine