



INSTALLATION & USER'S GUIDE

The Rekluse CoreManual TorqDrive Clutch Kit

Doc ID: 191-7113080A

Revision: 080118

TABLE OF CONTENTS

OVERVIEW	2
INSTALLATION TIPS	3
TOOLS NEEDED.....	3
INCLUDED PARTS	4
BIKE PREP & DISASSEMBLY	5
INSPECT THE DAMPERS.....	7
INSTALL HUBS	8
INSTALL THE CLUTCH PACK	10
PRESSURE PLATE INSTALLATION.....	13
MAINTENANCE.....	17
Clutch wear	17
Clutch parts	18
Preventive Maintenance.....	18
NEED ADDITIONAL HELP?.....	20

OVERVIEW

- This kit replaces the OE (Original Equipment) or “stock” core clutch components including the center clutch hub and pressure plate with high-quality billet components designed for optimal operation specific to your bike.
- All 8 OE friction disks will be replaced with Rekluse TorqDrive® Frictions, and all OE steel drive plates will be replaced with Rekluse TEC drive plates.
- All 6 of the OE drive pins will be reinstalled.
- If you install this product for a customer or another person, instruct them to read the **Safety Information** document and the **Installation and User Guide** before operating the bike with the product.

INSTALLATION TIPS

- Read this entire document before performing any steps, so you will know what to expect.
- Be sure to use proper eye protection.
- Laying the bike on its left side allows for easy clutch access and eliminates the need to drain oil.
- Use an air or electric impact wrench to remove the center clutch nut. If one is not available, you can place the bike in top gear and hold the rear brake while loosening the center clutch nut with a socket and breaker bar.
- Channel-lock pliers work best to bend the tabs of the washer up over the center clutch nut.
- Use clean, quality JASO-MA or JASO-MA2 certified transmission oil for best performance.

TOOLS NEEDED

- 8 mm socket
- 27 mm socket
- Channel-lock pliers
- Hammer
- Torque wrench (in-lb & ft-lb, or N-m)
- T-25 Torx bit (included with kit)
- Screwdriver

INCLUDED PARTS

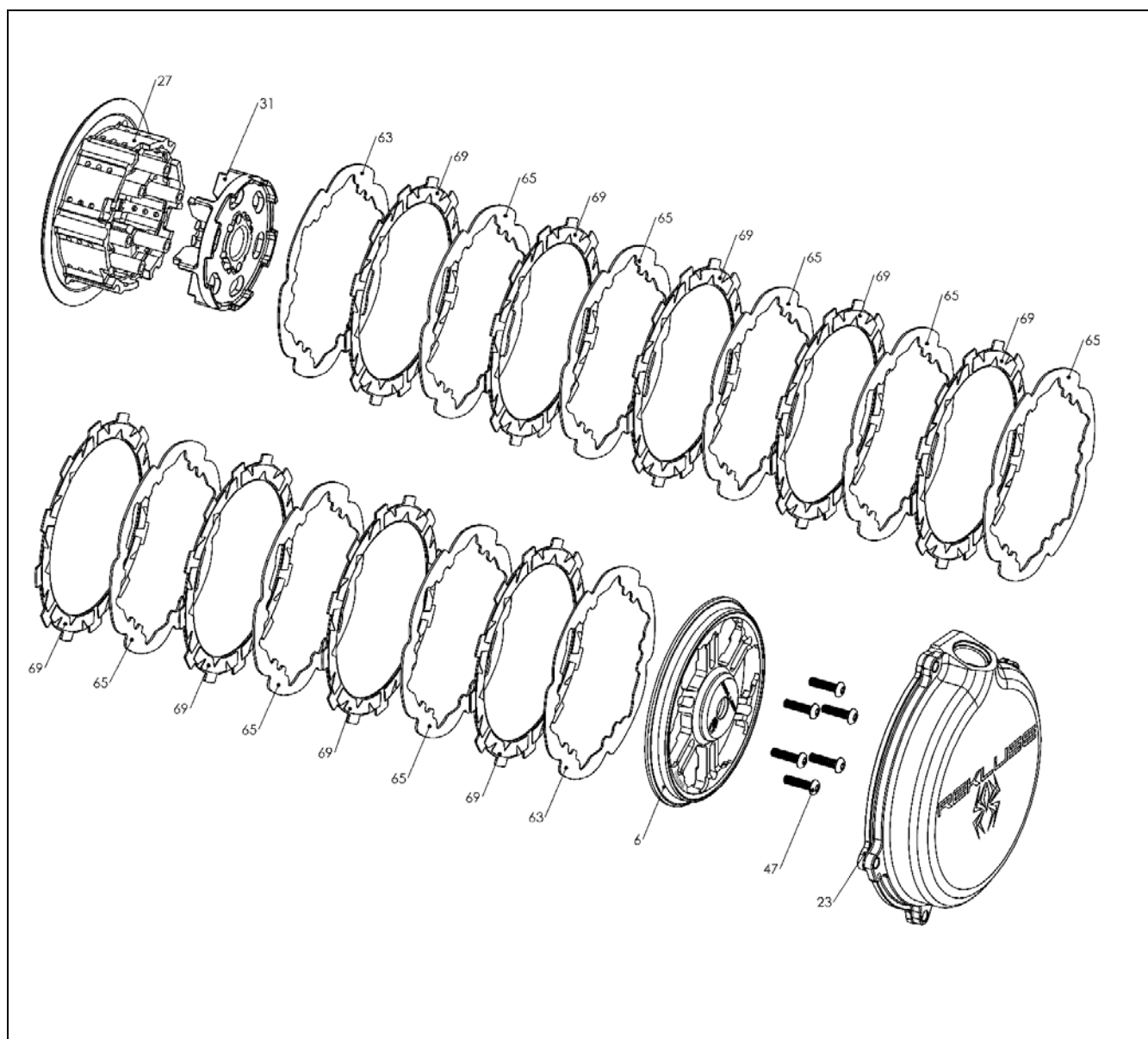

Item	Item Type	Qty
6	Pressure Plate	1
23	Clutch Cover	1
27	Outer Hub	1
31	Inner Hub	1
47	Pressure ring screws - T-25 Torx Screw (T-25 Torx bit included)	6
65	Steel Drive Plate - .040" (1 mm)	2
63	Steel Drive Plate - .048" (1 mm)	8
69	TorqDrive Friction Disks	9

Visit Rekluse.com/support for a full parts fiche illustration and part numbers.

BIKE PREP & DISASSEMBLY

1. Lay the bike on its left side. Catch any fuel that might drain in a suitable container.



2. Using a socket, remove the clutch cover bolts, then remove the clutch cover.

3. Remove the OE parts named in the following diagram.

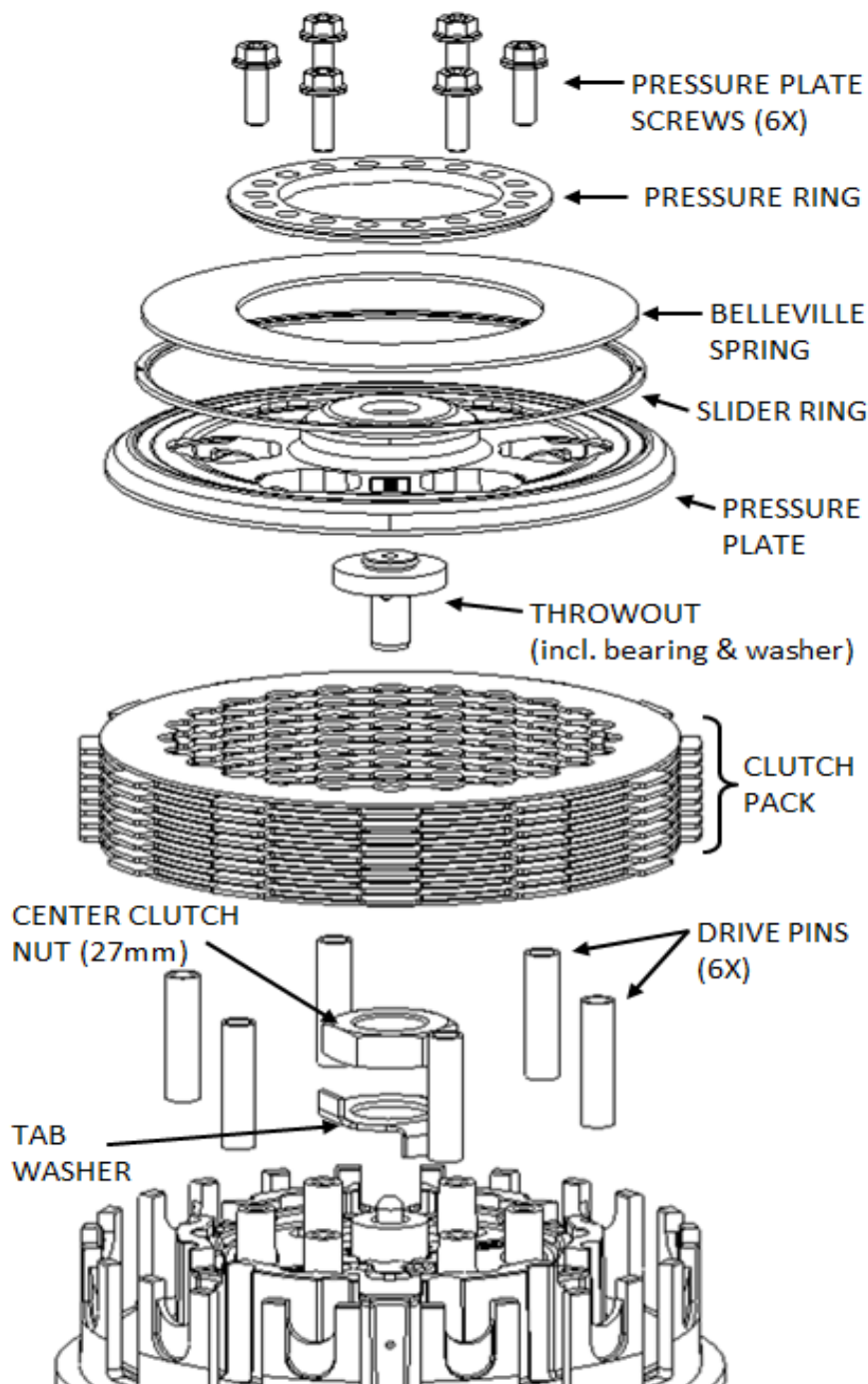

4. Soak the TorqDrive® friction disks in new engine oil for 5 minutes. Make sure the friction disks are coated on both sides.

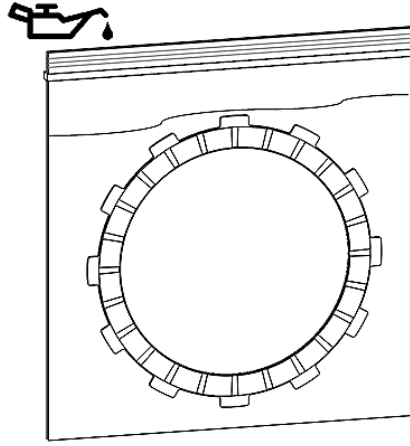

NOTES:

- Be careful that the drive pins do not fall into the engine while disassembling.

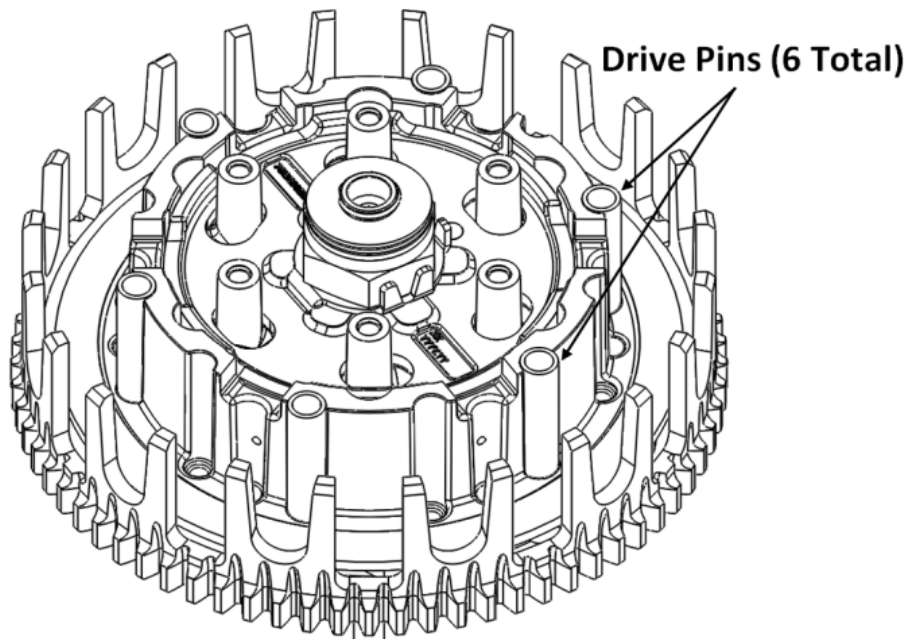

- Use a hammer and large screw driver to bend down the tabs of the tab washer.

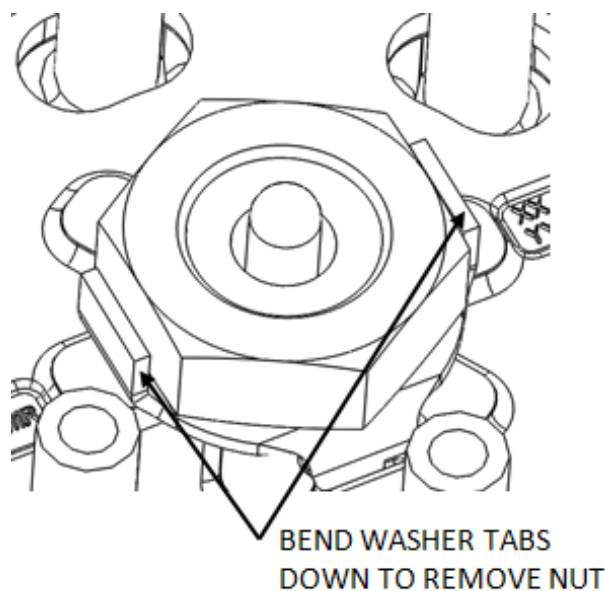

5. Remove the center hub assembly from the bike. *Make sure the thrust washer is in place on the main shaft and not stuck to the bottom of the center hub assembly.*

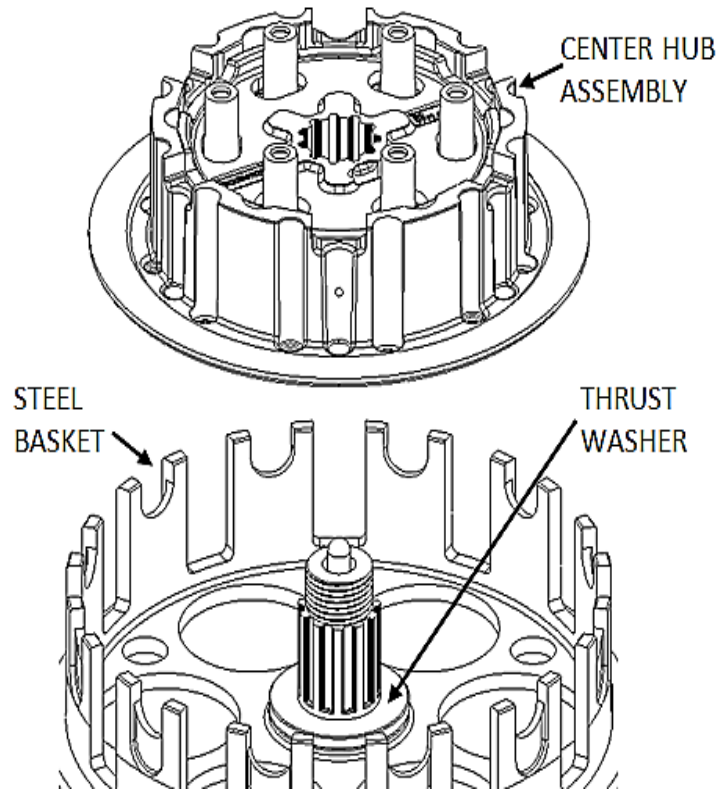

INSPECT THE DAMPERS

The OE dampers inside the center hub assembly shrink due to heat and use. Any movement between the dampers will shorten the life of your clutch. Inspect the dampers before proceeding and replace if necessary. Use the following instructions to inspect the dampers.

1. Hold the center hub assembly in your hands, then place your thumbs on the inner hub by the embossed part numbers.
2. Rotate the inner hub back and forth inside the outer hub. *Rekluse recommends replacing the dampers if you feel any play between the two hubs.*



INSTALL HUBS

1. If the dampers are in good condition, remove the 6 rubber dampers from the OE center hub assembly.

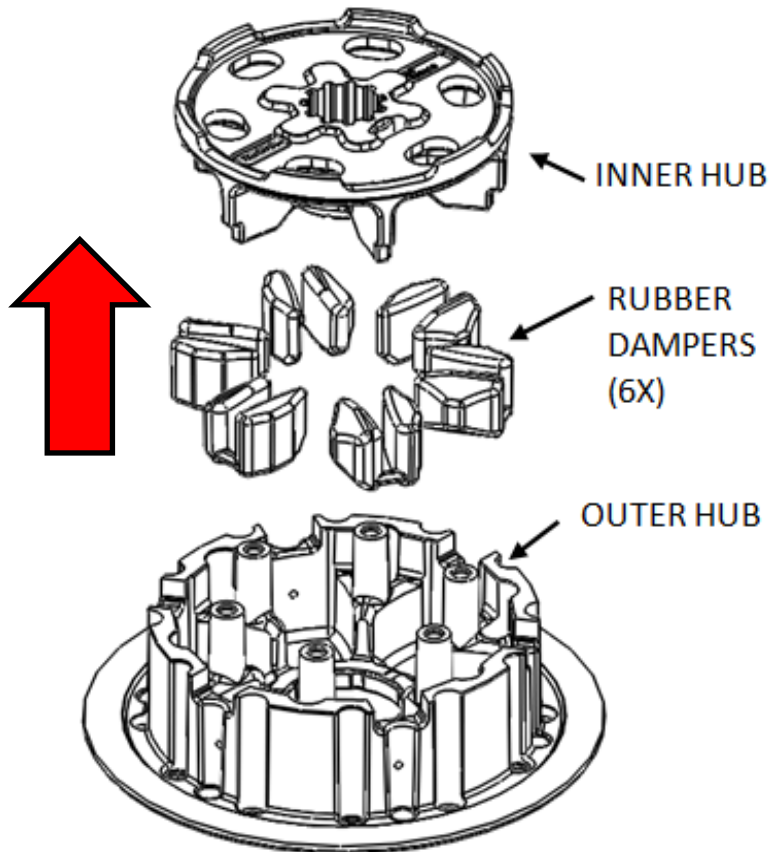

2. Install the 6 OE rubber dampers and the Rekluse inner hub onto the Rekluse outer hub.

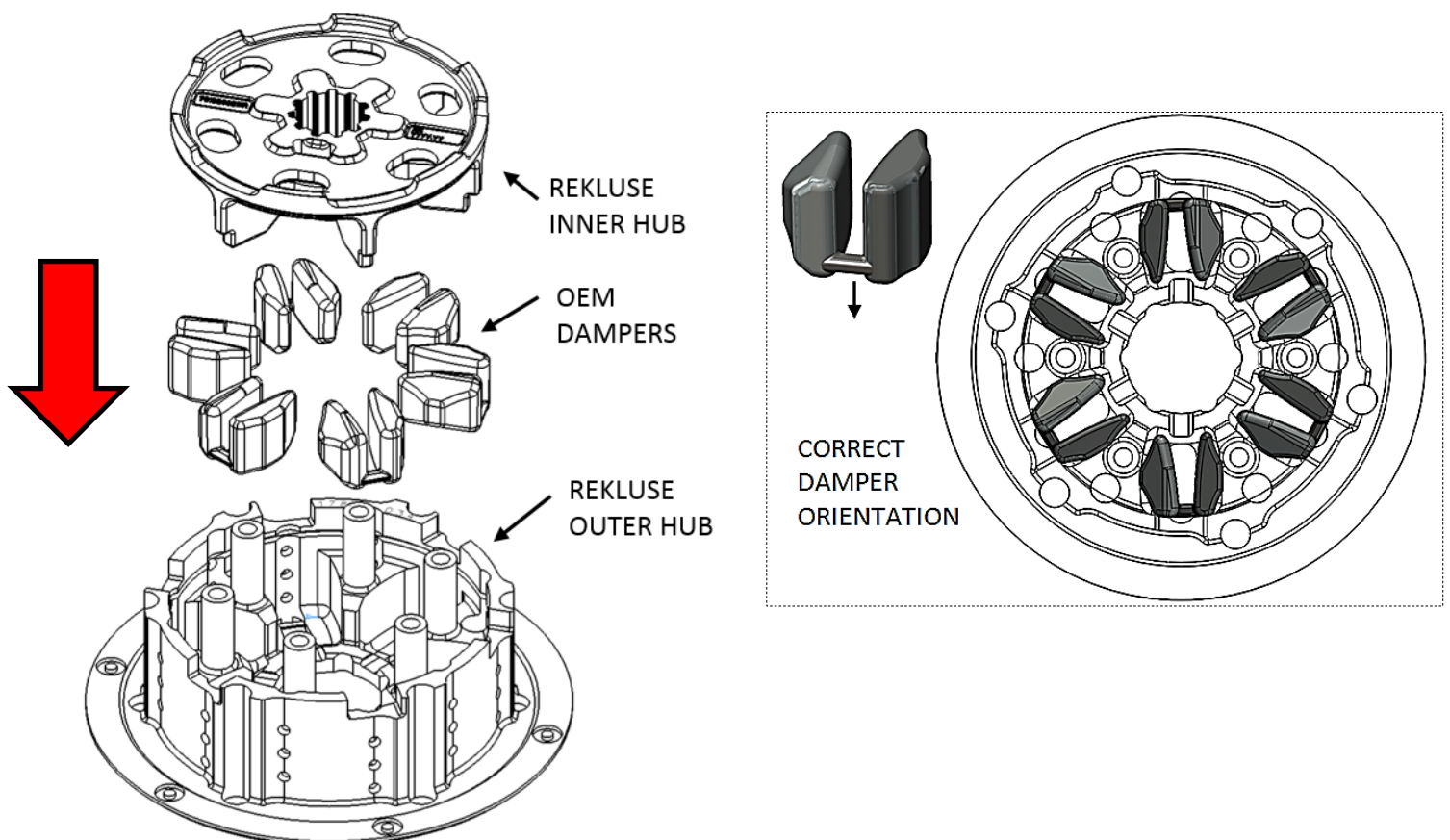

3. Install the new center hub assembly into the motorcycle. *Make sure the thrust washer is on the main shaft before installing.*

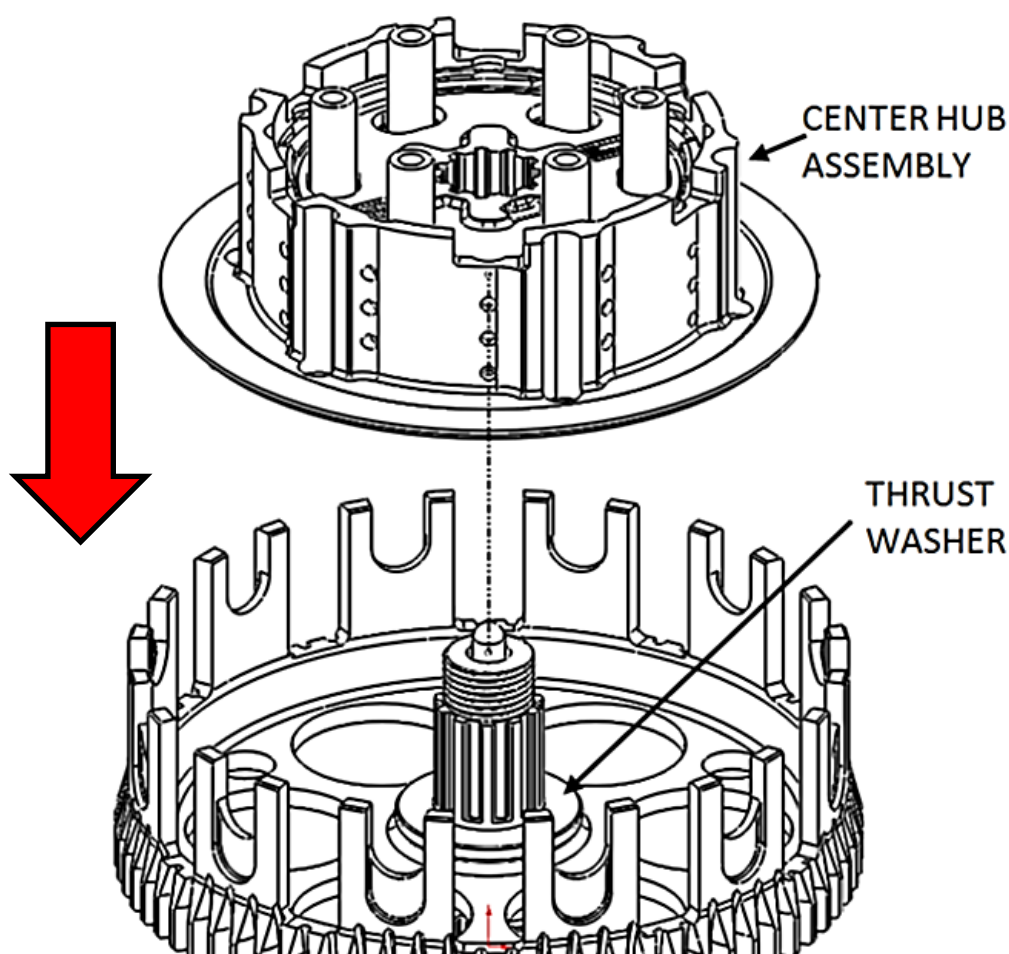

4. Reinstall the OE tab washer and center clutch nut torquing the nut to **50 ft-lb (68 N-m)**.
5. Using the channel-lock pliers, bend up **both** tabs of the tab washer tightly around the nut. The tabs can be bent on the straight sides or around the corners.

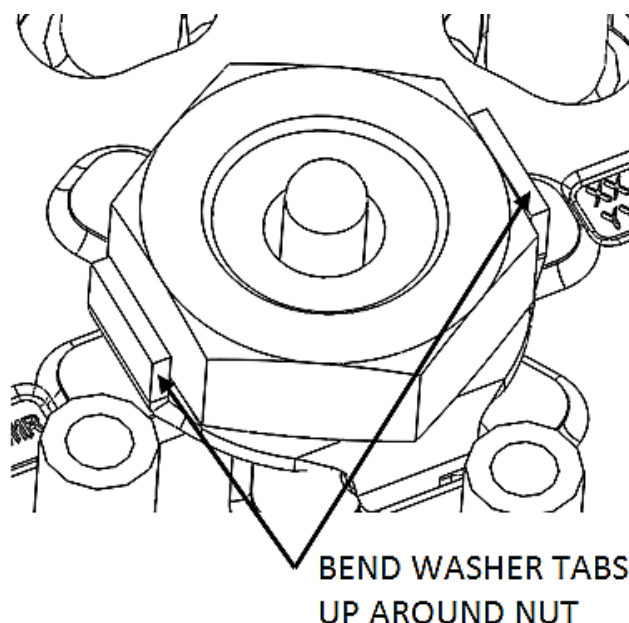

6. Seat the 6 OE drive pins into the Rekluse hub.

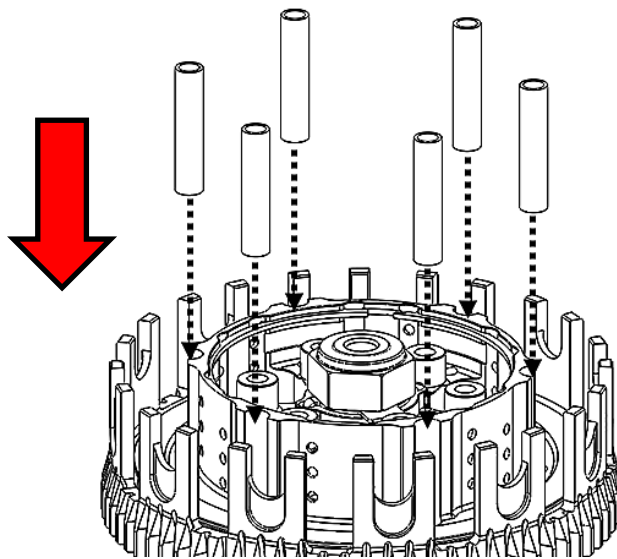

INSTALL THE CLUTCH PACK

1. Install 1 of the .040" (1 mm) thick drive plates in the orientation shown into the clutch basket. (All drive plates will follow this orientation).

NOTE: *Proper orientation of the drive plates is critical for optimal clutch performance. If you install them backwards, the clutch will still function but will lack proper modulation performance.*

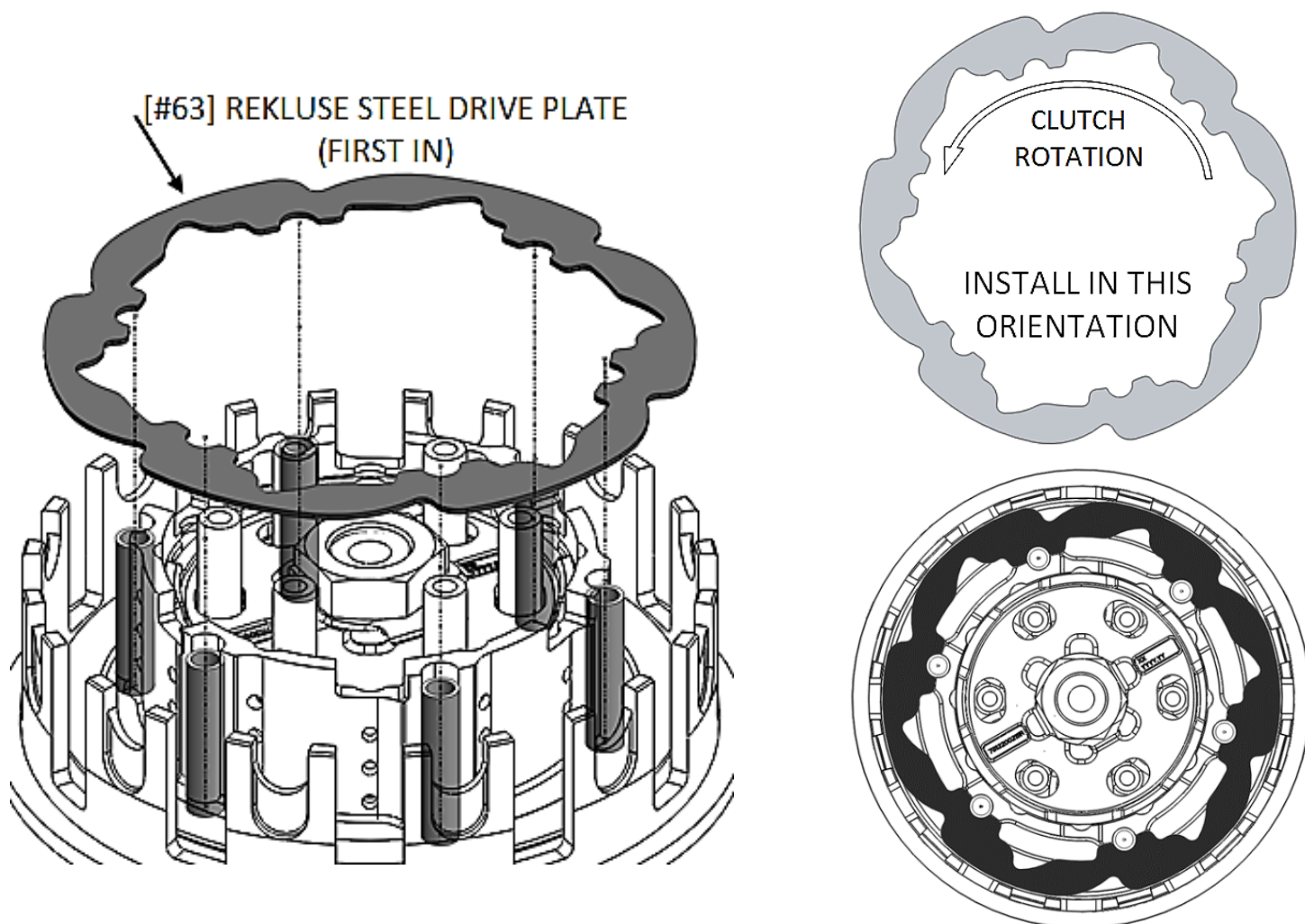

NOTES:

- Align the drive pin notches in the TEC drive plate with the drive pins on the hub when you install the drive plate into the basket. Be sure that the drive pins are seated in the notches and not in the bigger sections.
- ALL the TEC plates must be aligned in the drive pins notches or damage may occur. The plates will not move when installed correctly.

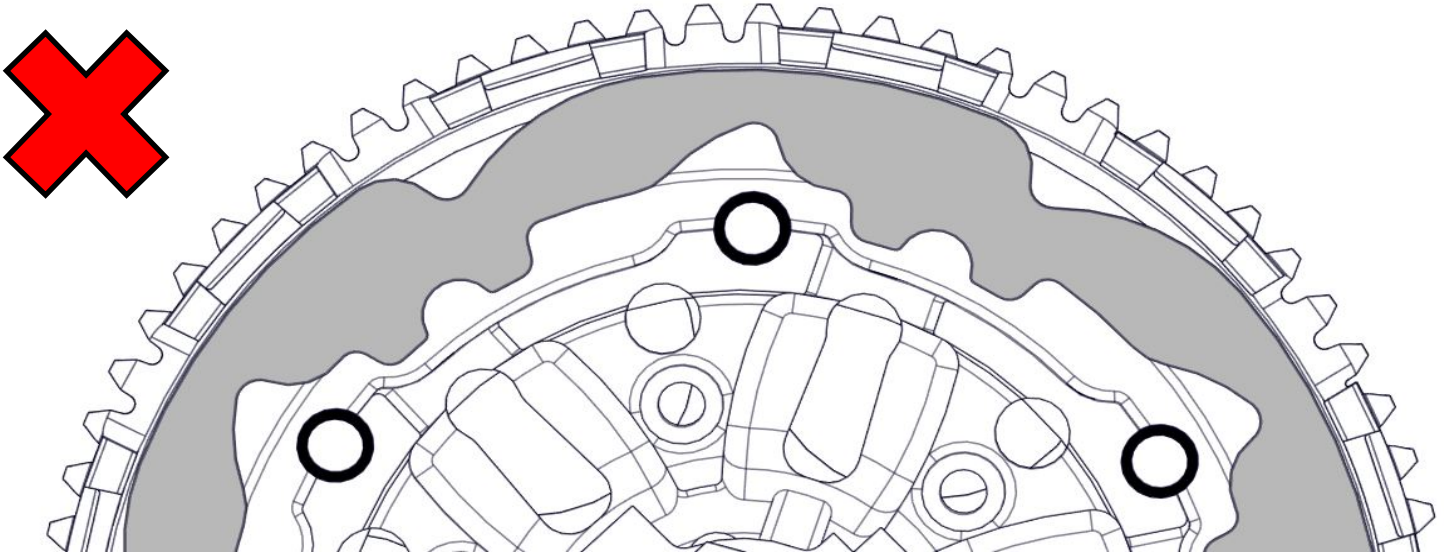
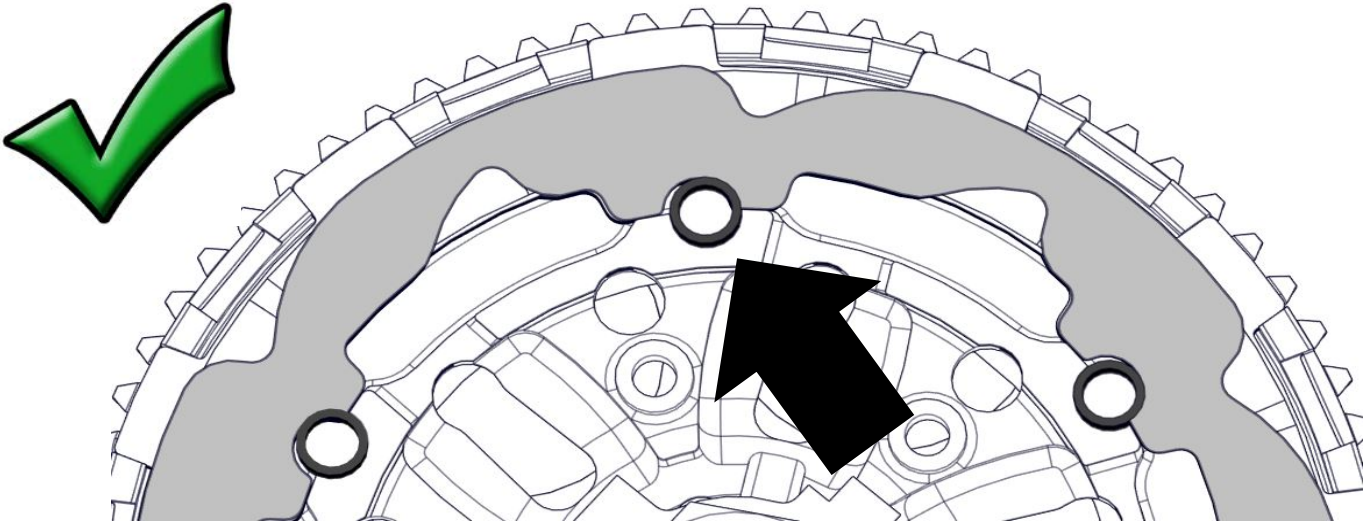

2. On top of the steel drive plate, install the rest of the clutch pack. The clutch pack number and order is based on the bike model. This information is found in the attached **Setup Sheet located at the back of the manual**. The following diagram is an example of the installed clutch pack.

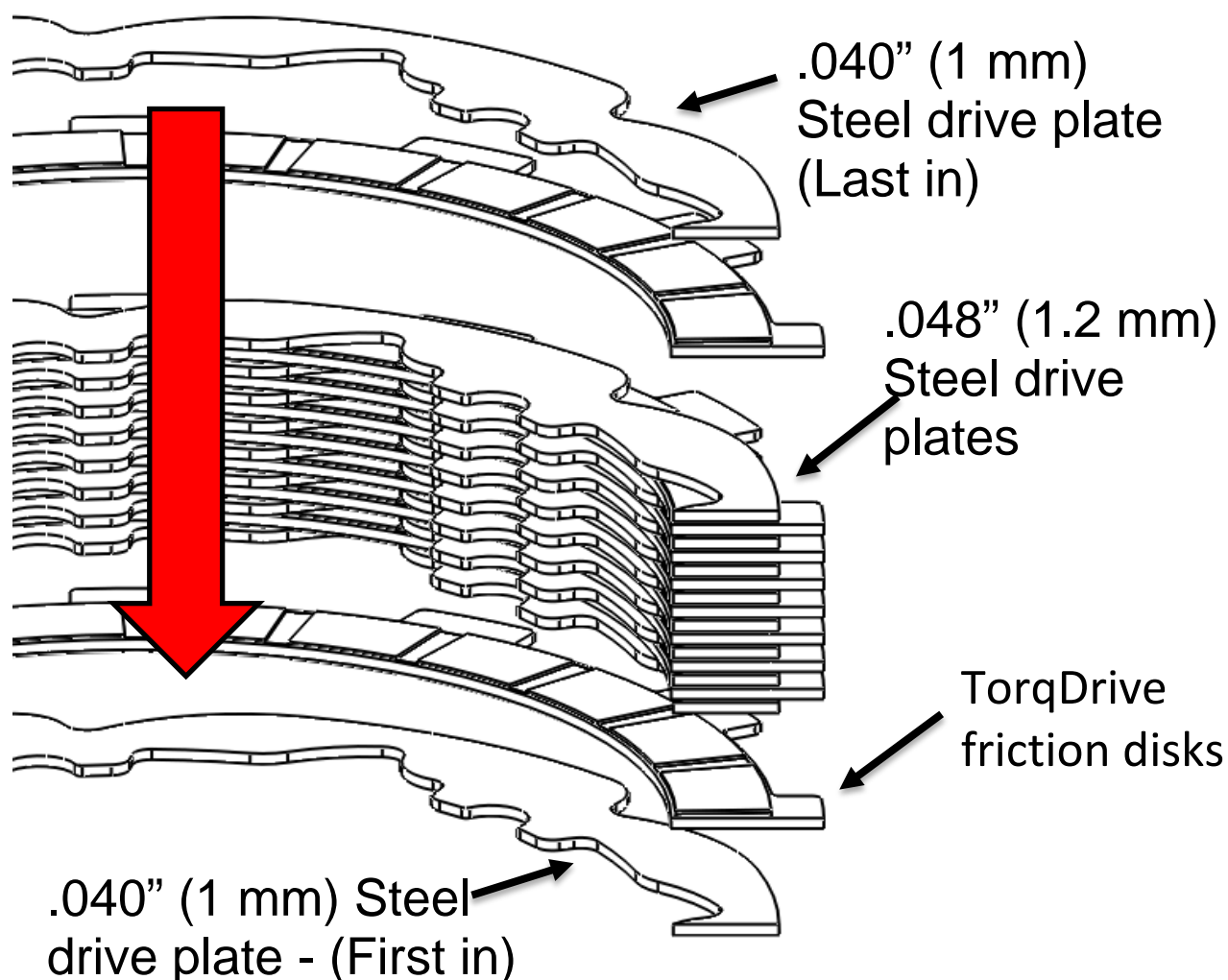

3. Reinstall the OE throw-out.

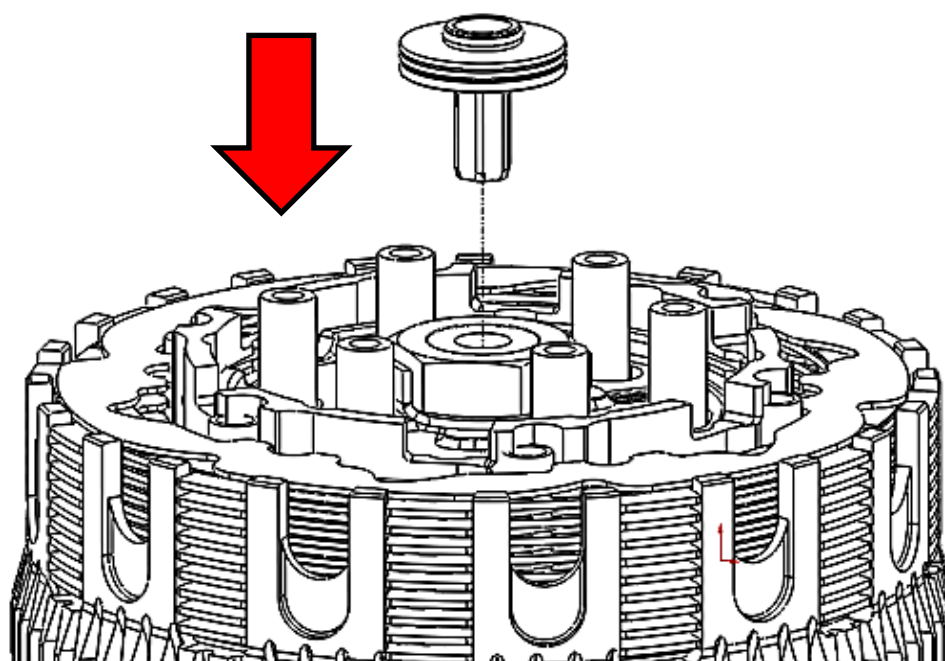

PRESSURE PLATE INSTALLATION

1. Install pressure plate by indexing the pressure plate into the slots in the hub.

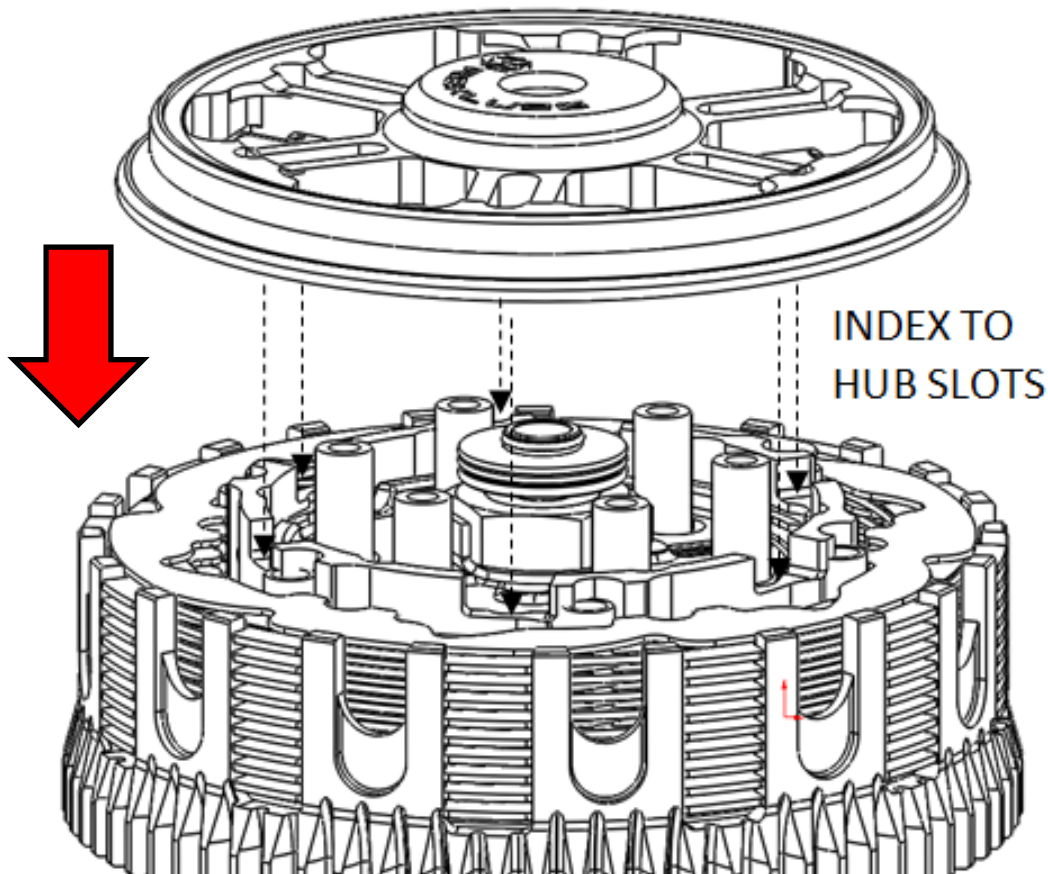

2. Place the OE slider ring on the pressure plate with the "top" marking facing up. (The top side is rounded and the bottom edge is sharp.)

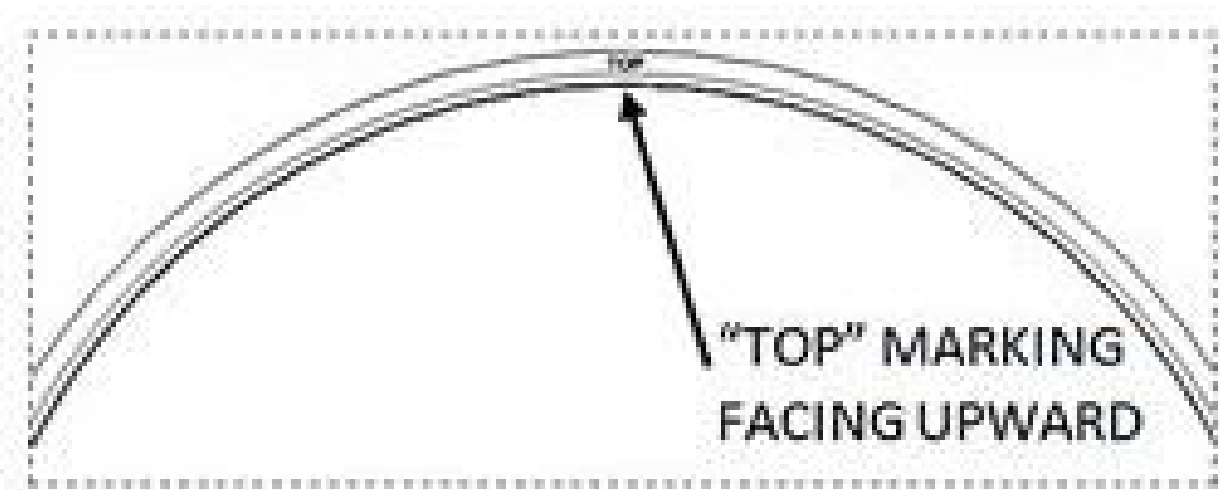

3. Install the OE Belleville spring onto the slider ring, with the rounded dome side facing up. See pictures for reference.

NOTE: *The outer edge of the Belleville spring will make contact with the slider ring. If it does not, the Belleville spring is upside down.*

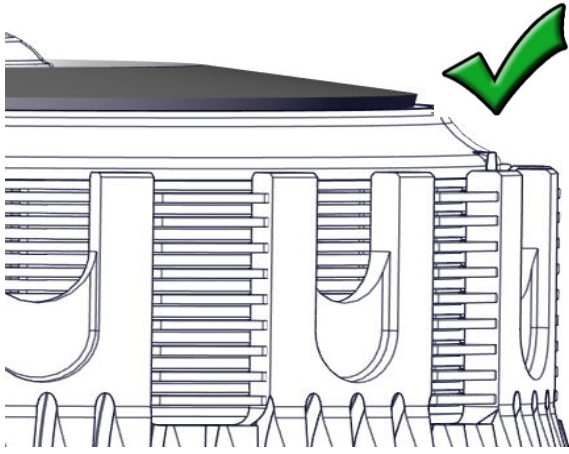

Correct – The Belleville spring sits flat against the slider ring.

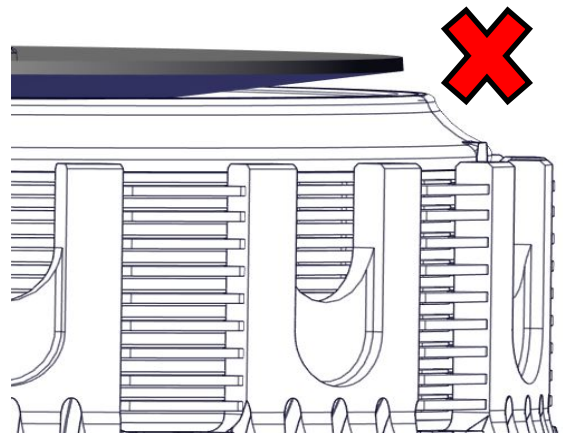

Incorrect – The Belleville spring is upside down.

4. Install the OE pressure ring followed by the Rekluse Pressure Plate Screws.

NOTE: There are 3 possible settings on the OE pressure ring. Rekluse recommends setting Y/II (4-strokes) or Y/II (2-strokes) for optimum clamping force and performance. See the **Setup Sheet** located at the back of the manual for more information.

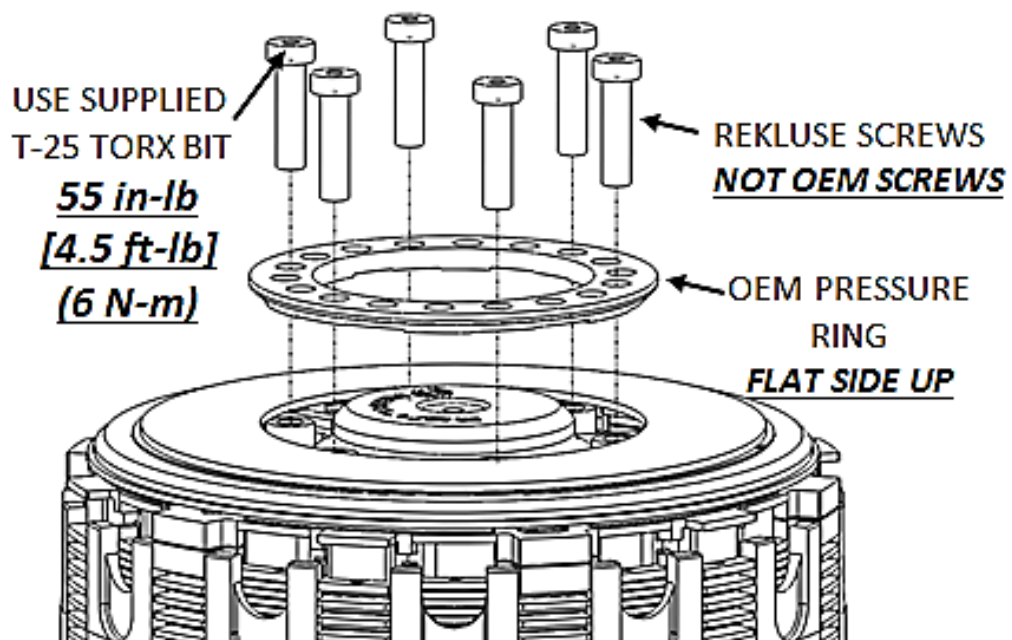

CAUTION

DO NOT reuse the stock screws, or clutch cover interference will occur! **DO NOT** over-torque the screws, or damage to the screw heads will occur!

5. Torque the pressure ring screws to **55 in-lb (4.5 ft-lb) (6 N-m)**.
6. Install the OE cover gasket onto the Rekluse clutch cover, then install the cover onto the clutch.
7. Reinstall the clutch cover bolts in their proper location, then lightly tighten the cover bolts in small increments in a star pattern. Torque the cover bolts to OE specifications.

250/300 2 stroke 2017+ models:

- **Use 6 OEM bolts and 1 Rekluse bolt.** Your Rekluse clutch cover kit comes with 1 longer bolt to replace a shorter OEM bolt. Install 6 of the OEM bolts in their original location and install the longer Rekluse bolt in the lower right hand corner. **See following pictures for reference.**

 CAUTION

Failure to install the OEM clutch cover bolts back in their proper location can result in damage to your motorcycle.

250/300 2 stroke 2017+ models:

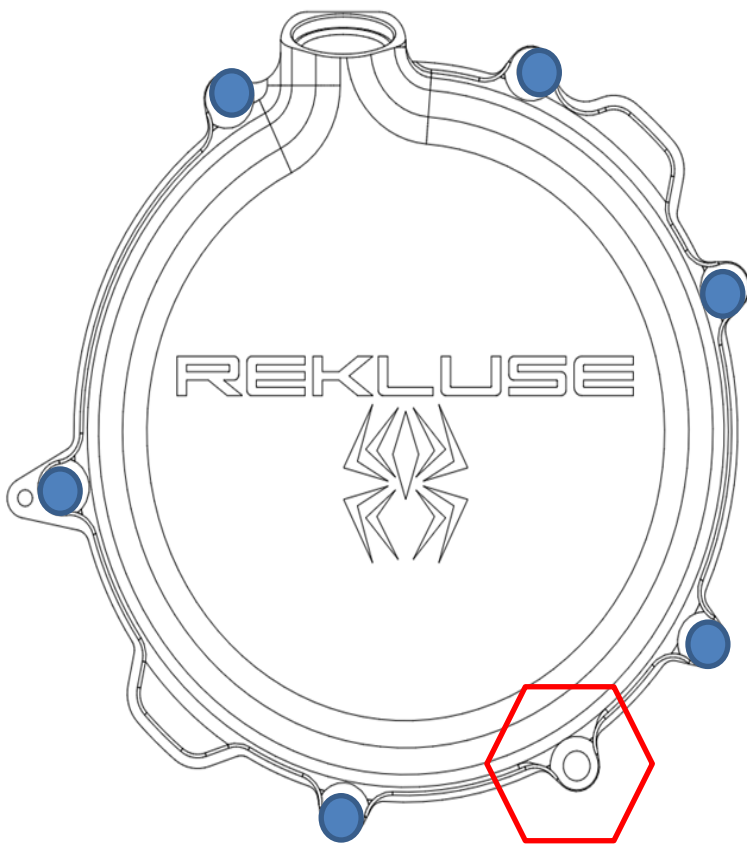

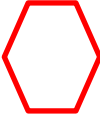
-  --OE bolts
-  --Rekluse bolt

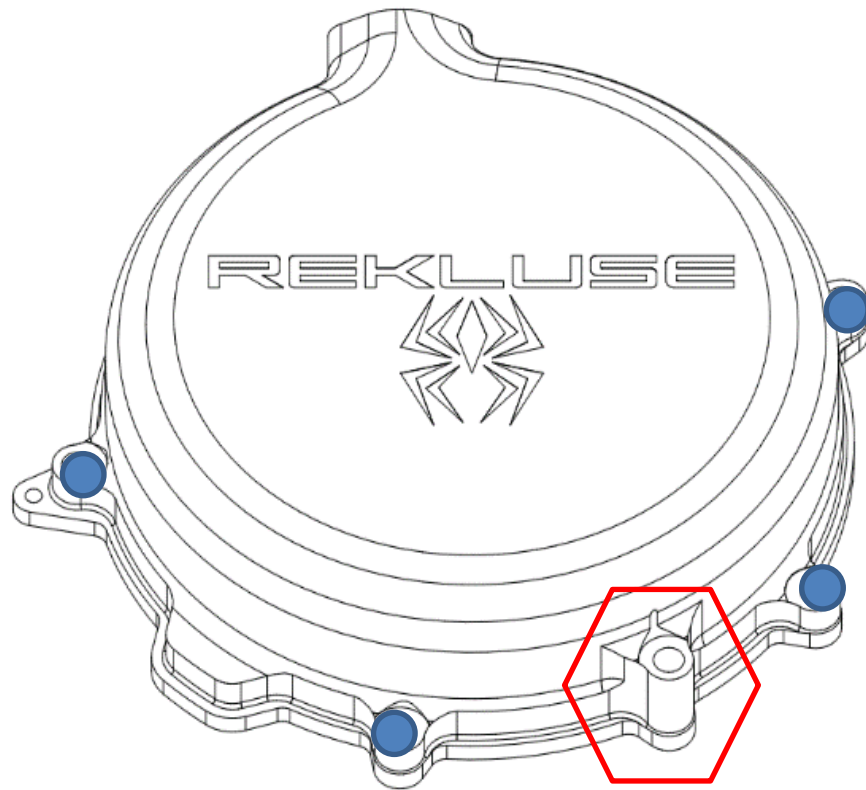

8. If your clutch cover has an oil fill plug and/or engine inspection plug, reinstall the plug.

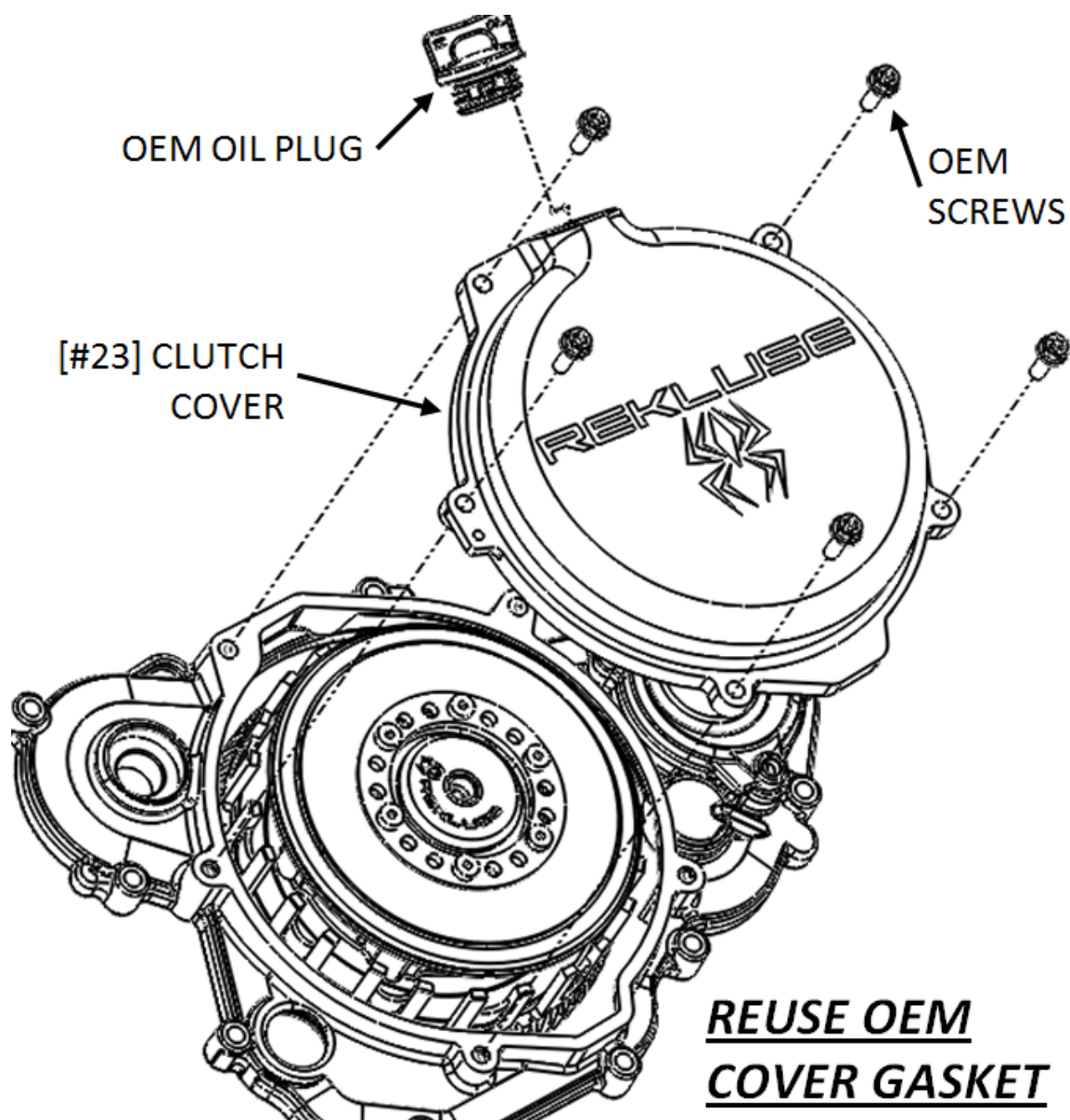

MAINTENANCE

Clutch wear

Rekluse clutches are built using high quality materials but do wear based on the rider's use, type of terrain, and natural wear and tear.

- Clutch longevity and performance is greatly increased with oil quality and other bike factors that reduce engine heat.
- Riding style, such as speed, engine RPM, and terrain can also effect the life of the clutch.
- To keep your clutch performing at its best, perform regular maintenance on your bike and clutch based on your riding style.

- The maintenance range is based on an average rider's moderate use. If you ride in extreme environments or riding conditions, use the lower end of the range for best performance.

Clutch parts

Inspect all of your clutch parts at regular intervals for signs of wear or excessive heat, and replace components as necessary.

- The OE spring ring can be optimized based on the wear and height of the clutch pack. See the attached Setup Sheet for the specific clutch pack measurements.
- Repeat the break-in procedure anytime you replace the frictions disks. Always soak new friction disks in fresh oil before installing.
- Measuring the clutch pack can help determine if the components need replacing. The clutch pack is measured with the entire clutch pack together. Include the friction pad in the measurement.
- Disk inspection examples are found in the following section.

Measure entire clutch pack including the friction pad.

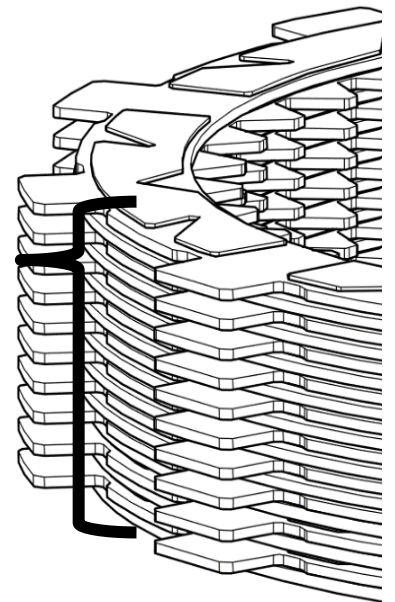

Preventive Maintenance

- Use clean, quality oil with the JASO-MA or JASO-MA2 certification for motorcycles for best performance.
- Keep up with regular oil changes as per the bike manufacturer's recommendations. Clutch performance and longevity depend on oil quality.
- Change the oil filter and/or clean the oil screen with every oil change.

- **Disk inspection examples:** When inspecting the clutch pack, the following pictures can be used as a reference. **These are best viewed in color by viewing this install document on our website at www.rekluse.com/support.**

Drive Plates – If the clutch pack is getting high amounts of heat, purple, blue, or black color can be seen on the drive plate teeth. See pictures below. Not all drive plates look the same and may look different than pictured.



Normal Heat

High Heat
(Blue)

Excessive Heat
(Black)

Friction Disks – Due to the dark color of the friction material, the friction disks will appear almost black as soon as they are put in oil. During inspection, look for glazing of the friction material. Glazing will appear shiny and feel like glass, even after oil is cleaned from the friction disk. Not all friction disks look the same and may look different than pictured.



Normal Friction



Glazed Friction

NEED ADDITIONAL HELP?

Website

www.rekluse.com/support

Frequently Asked Questions

www.rekluse.com/faq

Support Videos

www.rekluse.com/support/videos

Phone

(208) 426-0659

Technical Support

Contact Technical Support for questions related to product installation, tuning, and performance.

Hours:

Monday thru Friday: 8:00 a.m. - 5:00 p.m.

Mountain Time zone

Email: tech@rekluse.com

Customer Service

Contact Customer Service for additional product information, orders, and returns.

Hours:

Monday thru Friday: 8:00 a.m. - 5:00 p.m.

Mountain Time zone

Email: customerservice@rekluse.com

