

THIS SHEET INCLUDES FITTING INSTRUCTIONS FOR THE FOLLOWING PARTS:

Secondary Alternator Cover Part No. EC-ZXR400-2018-1-GBR / Secondary Clutch Cover Part No. EC-ZXR400-2018-2-GBR /  
Secondary Water Pump Cover Part No. EC-ZXR400-2018-5-GBR /  
Lower Chain Guard Part No. CGA18-GBR-SET



**SECONDARY ALTERNATOR COVER**  
**PART NO. EC-ZXR400-2018-1-GBR**

1. Remove nearside lower belly panel. The lower part of the main fairing panel will need to be loosened to allow for access to Bolt 4 in terms of its removal and replacement.
2. Remove 4 existing bolts from the stock Alternator cover, shown as position Bolt 1, 2, 3 & 4.
3. Place the Secondary Alternator Cover over the stock cover.
4. Assemble 4 replacement bolts loosely in the correct positions as shown: 3 x M6X40HHF & 1 x M6X45HHF.
5. Tighten bolts to a Torque of 11Nm as per manufacturer's recommendations. DO NOT OVERTIGHTEN.
6. Re-fit lower belly panel.

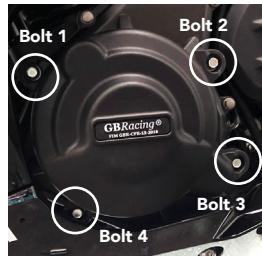

**SECONDARY CLUTCH COVER**  
**PART NO. EC-ZXR400-2018-2-GBR**

1. Remove Lower Fairing panel.
2. Remove 4 existing bolts from the Clutch cover, shown as position Bolt 1, 2, 3 & 4.
3. Place the Secondary Clutch Cover over the stock cover.
4. Assemble 4 replacement bolts M6X30HHF loosely in the correct position as shown.
5. Tighten bolts to a Torque of 11Nm as per manufacturer's recommendations. DO NOT OVERTIGHTEN.
6. Re-fit Lower Fairing panel.

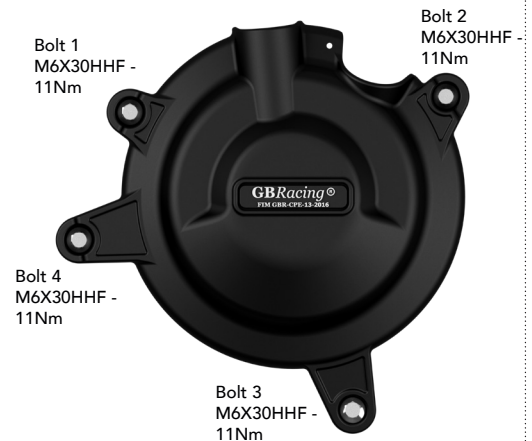
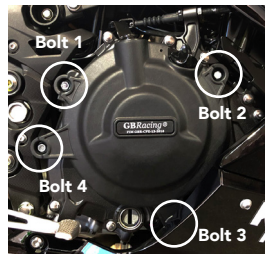

**SECONDARY WATER PUMP COVER**  
**PART NO. EC-ZXR400-2018-5-GBR**

1. Remove Lower Fairing panel.
2. Remove 3 existing bolts from the water pump cover, shown as position Bolt 1, 2, & 3.
3. Place the Secondary water pump cover the stock cover.
4. Assemble 3 replacement bolts M6X55HHF loosely in the correct position as shown.
5. Tighten bolts to a Torque of 11Nm as per manufacturer's recommendations. DO NOT OVERTIGHTEN.
6. Re-fit Lower Fairing panel.

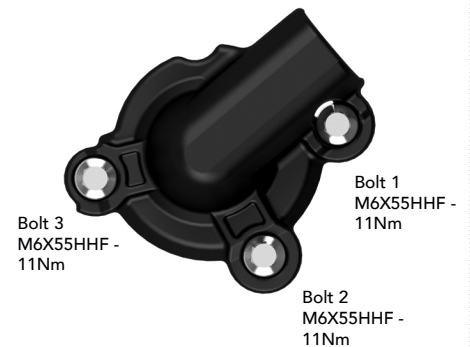
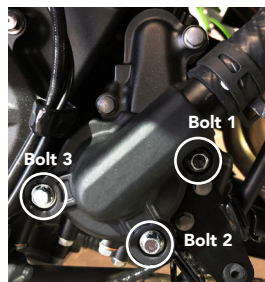

**Engine Cover Set: EC-ZXR400-2018-SET-GBR**

EC-ZXR400-2018-1-GBR, EC-ZXR400-2018-2-GBR, EC-ZXR400-2018-5-GBR

[www.GBRacing.eu](http://www.GBRacing.eu)