



LP0196

FITTING INSTRUCTIONS FOR LP0196BK LICENCE PLATE BRACKET
HUSQVARNA 701 ENDURO/SUPERMOTO 2016-

Page | 1



THIS KIT CONTAINS THE ITEMS PICTURED AND LABELLED BELOW.
DO NOT PROCEED UNTIL YOU ARE SURE ALL PARTS ARE PRESENT.

Please note that the way the kit is packed does not necessarily represent the way of mounting to the bike

THE PARTS SHOWN MAY BE REPRESENTATIVE ONLY (FOR CLARITY OF INSTRUCTIONS ONLY)

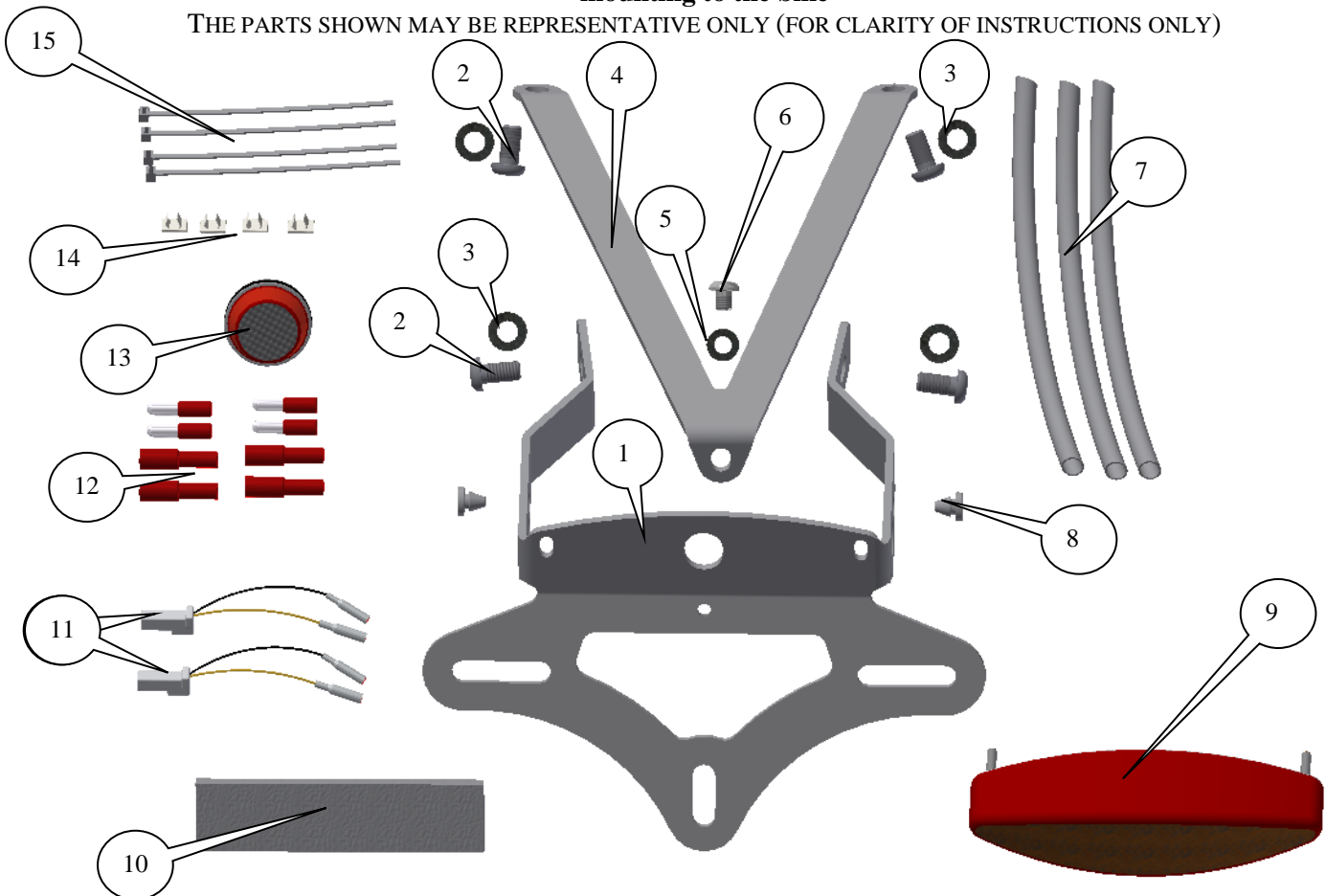

R&G Racing

Unit 1, Shelley's Lane, East Worldham, Alton, Hampshire, GU34 3AQ

Tel: +44 (0)1420 89007 Fax: +44 (0)1420 87301 www.rg-racing.com Email: info@rg-racing.com



LP0196

Page | 2

LEGEND

- ITEM 1 = MAIN LICENCE PLATE BRACKET (TB0196 PART 1) (x1).
- ITEM 2 = M6 x 12mm LONG BUTTON HEAD BOLT (x4).
- ITEM 3 = M6 WASHERS (x4).
- ITEM 4 = LICENCE PLATE SUPPORT BRACKET (TB0196 PART 2) (x1).
- ITEM 5 = M5 WASHERS (x1).
- ITEM 6 = M5 x 6mm LONG BUTTON HEAD BOLT (x1).
- ITEM 7 = 150mm LENGTH OF HEAT SHRINK (x3).
- ITEM 8 = RB50-20-00FG RUBBER GROMMETS (x2)
- ITEM 9 = LA0005 REAR LIGHT ASSEMBLY (RED) (x1).
- ITEM 10 = 150mm LENGTH OF BLACK SELF ADHESIVE FOAM (x1).
- ITEM 11 = INDICATOR CONNECTORS (CON0014) (x2).
- ITEM 12 = REAR LIGHT CONNECTORS (CON0004) (x2).
- ITEM 13 = REFLECTOR (REFL 1) (x1).
- ITEM 14 = SELF ADHESIVE CABLE CLIPS (x4).
- ITEM 15 = SMALL CABLE TIES (x2).

Please note that in cases where kits are packed with rubber washers holding the components onto the bolt – *the rubber washers should be thrown away!*

TOOLS REQUIRED

- Set of Metric Allen keys to include 3 and 4mm A/F.
 - T30 Torx bit or key.
 - 13mm Spanner.
- Small amount of super glue.

Digital copies of these instructions are available to download from www.rg-racing.com

GENERAL TORQUE SETTINGS

- M4 BOLT = 8Nm
- M5 BOLT = 12Nm
- M6 BOLT = 15Nm
- M8 BOLT = 20Nm
- M10 BOLT = 40Nm

R&G Racing
Unit 1, Shelley's Lane, East Worldham, Alton, Hampshire, GU34 3AQ
Tel: +44 (0)1420 89007 Fax: +44 (0)1420 87301 www.rg-racing.com Email: info@rg-racing.com



LP0196

Page | 3



PICTURE 1



PICTURE 2



PICTURE 3

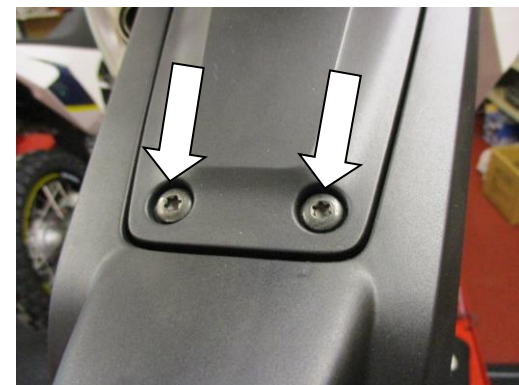

PICTURE 4

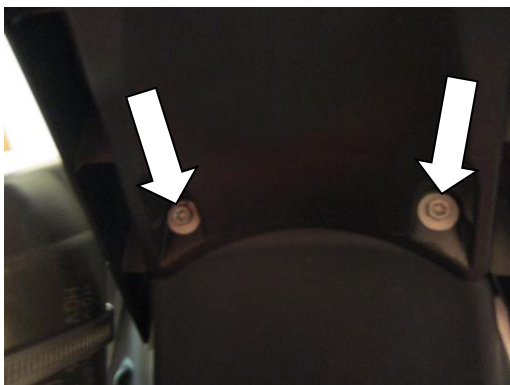

PICTURE 5

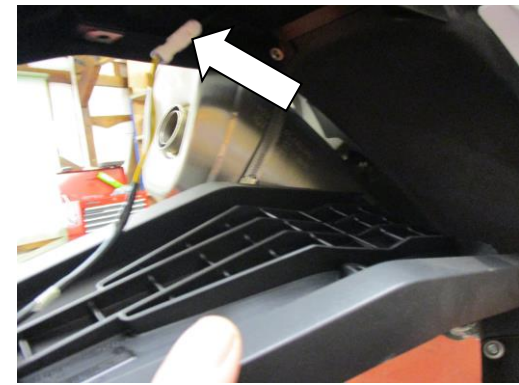

PICTURE 6



LP0196

Page | 4

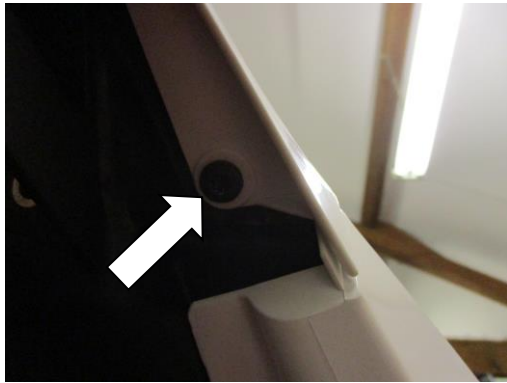

PICTURE 7

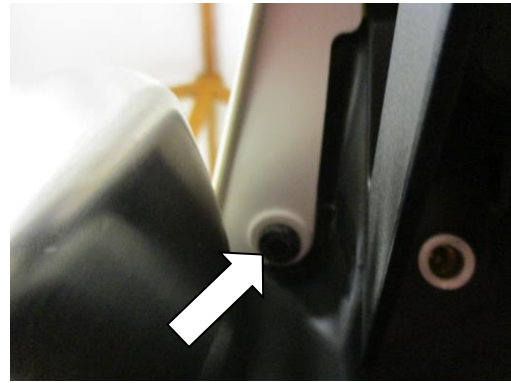

PICTURE 8

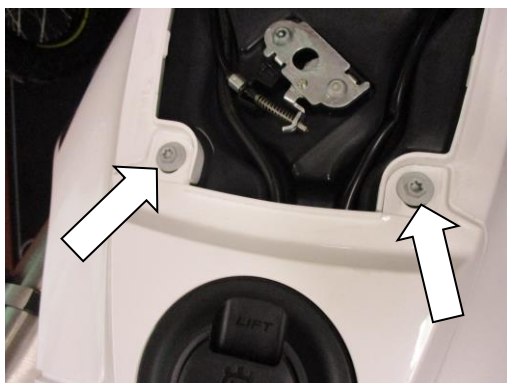

PICTURE 9



PICTURE 10



PICTURE 11



PICTURE 12



LP0196

Page | 5



PICTURE 13

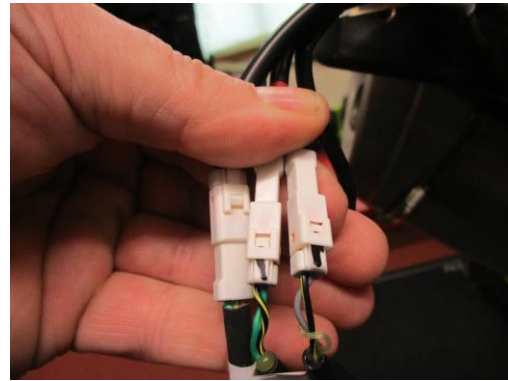

PICTURE 14



PICTURE 15



PICTURE 16



PICTURE 17



PICTURE 18



LP0196

Page | 6

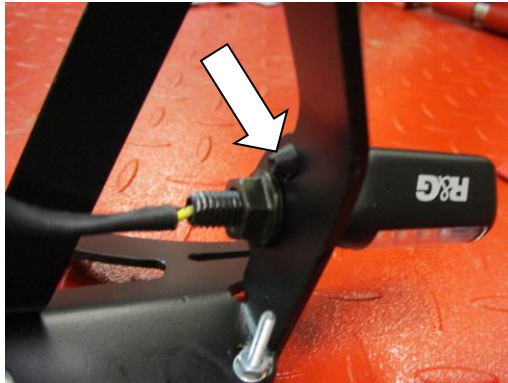

PICTURE 19



PICTURE 20



PICTURE 21



PICTURE 22



PICTURE 23



PICTURE 24



LP0196

Page | 7



PICTURE 25



PICTURE 26



PICTURE 27



PICTURE 28



PICTURE 29

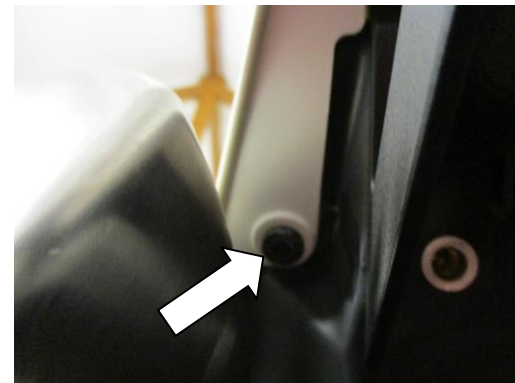

PICTURE 30



LP0196

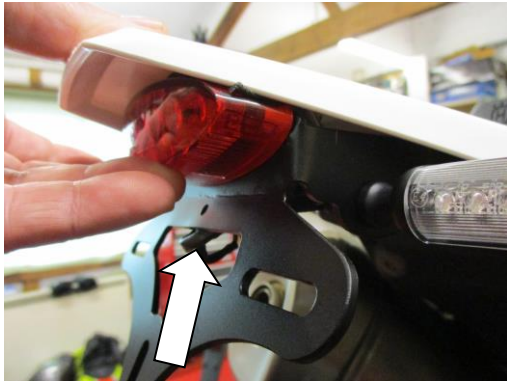

PICTURE 31



PICTURE 32



PICTURE 33



PICTURE 34

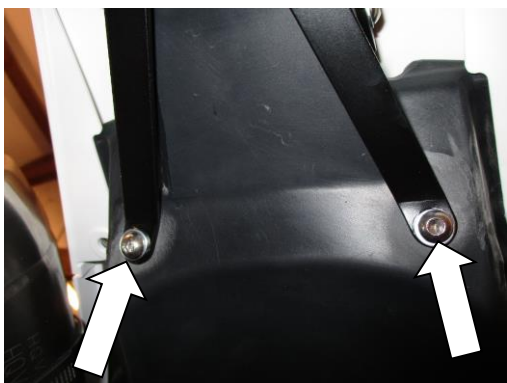

PICTURE 35

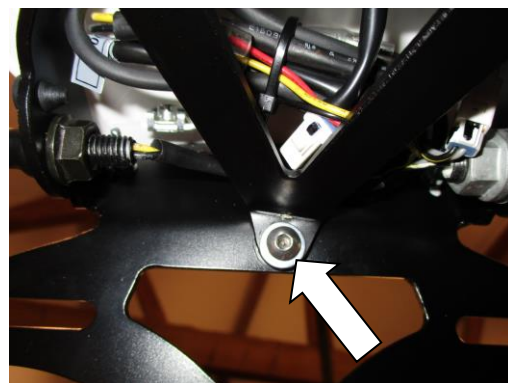

PICTURE 36



LP0196

FITTING INSTRUCTIONS

- Remove the seat using the pull cable arrowed in picture 1 and unsnapping the two location spigots shown in pictures 2 and 3.
- Remove the four bolts arrowed in pictures 4 and 5 and gently lower the licence plate bracket under-tray as shown in picture 6.
- Disconnect the licence plate illuminator plug socket arrowed in picture 6 and remove the licence plate bracket under-tray.
- Remove the six bolts arrowed in pictures 7, 8, 9 and 10.
- Remove the fuel cap as shown in picture 11.
- Remove the rear cowl as shown in picture 12 and replace the fuel cap until ready for reassembly.
- Remove the cable ties and disconnect the rear light and indicator plug sockets as shown in pictures 13 and 14 (*It's a good idea to mark the matching connectors up at this stage to make re-fitting easier*).
- Remove the two bolts arrowed in pictures 15 and 16 and carefully remove the original licence plate bracket.
- If you intend to re-use the OEM indicators, then remove the indicator mounting nut arrowed in picture 17 then fit to the new licence plate bracket (item 1) as shown in picture 18 (repeat for opposite side noting which side they were removed from).
- If using mini indicators fit the indicators of choice to the new licence plate bracket (item 1) (R&G mini indicator product code RG370 for bulb type and RG371 for LED type or RG372 for Aero Style led type) as shown in picture 19 (please use the provided heat shrink (item 7) to protect the wiring). *If fitting the R&G Mini Indicators, use the two rubber grommets (item 8) to plug the unused holes as arrowed in pictures 19 and 20.*
- Take the R&G Licence Plate Bracket (item 1) and fit the new rear light (item 9), as shown in pictures 19 and 20 (a clear lens option is also available--product code LA0003). (Please use the heat shrink (item 7) to protect the new rear light wiring).
- Cut to size and stick the foam strip (item 10) to the upper edge of the light as shown in pictures 21 and 22.
- Offer the licence plate bracket assembly up to the underside of the tail unit (as shown in picture 23, 24 and 25) and use two of the M6 bolts with washers (items 2 and 3) to hold in position as shown in pictures 23, 24 and 25 (do not fully tighten the bolts at this stage).
- Connect the indicator wiring plug sockets (as they were marked up earlier) (if using R&G mini indicators please use the two connectors (item 11= the ones with two wires) to connect to the main loom as shown in picture 26. If the indicator fail to work please swap the connectors over. Please use the supplied cable ties and self-adhesive clips to tidy and secure the wiring.
- Using the Scotch block connectors supplied re-attach the rear light wiring as detailed below and shown overleaf.

OEM WIRES-----R&G WIRES
GREEN-----BLACK=EARTH/RETURN
YELLOW----- RED=BRAKE LIGHT
LIGHT BROWN/ORANGE----- YELLOW=RUNNING/SIDE LIGHT AND LICENCE
PLATE ILLUMINATOR

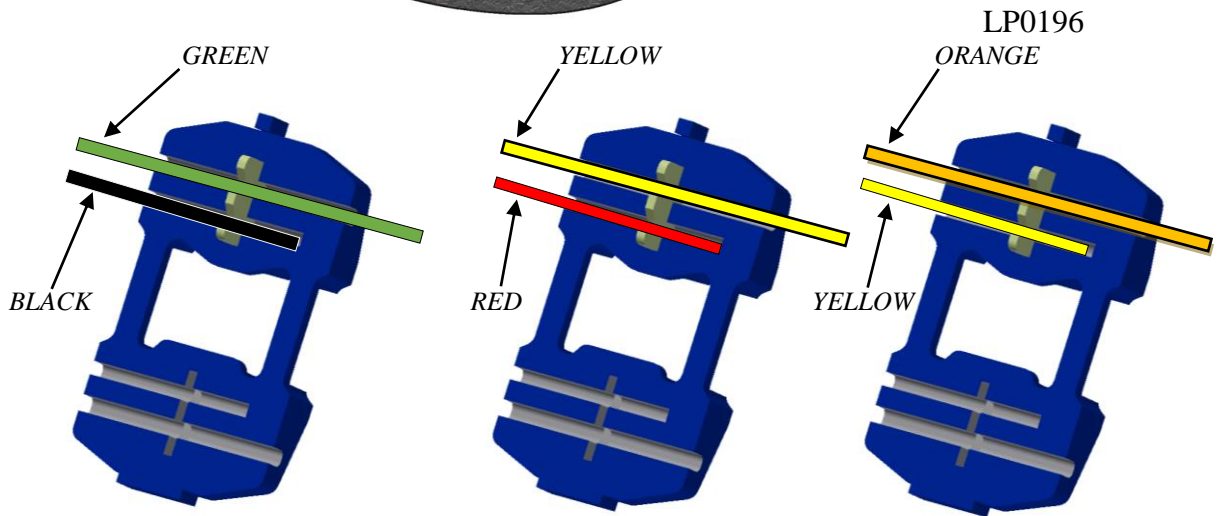

- Alternatively you can cut and shut the original plug socket from the original rear light using the bullet connectors (item 12) as detailed below.
- **Take the OEM tail light with the connector on, and cut the wires, about 4cm up from the connector. Strip back the ends of the three wires and fit three male bullet connectors supplied (item 12 – CON0004).**
- **Connect three female bullet connectors to the new tail light wiring and connect as indicated above. Reconnect the rear light plug socket, it is a good idea to test indicator and rear light operation at this stage, if any lights do not illuminate, switch the bullet connectors around.** Please use the supplied cable ties and self-adhesive clips to tidy and secure the wiring.
- Remove the fuel cap and refit the rear cowl as original as shown in picture 27.
- Replace the fuel cap as shown in picture 28.
- Refit the original bolts to secure the rear cowl as shown in pictures 9, 29 and 30 as original (the two bolts shown in picture 10 are not reused).
- Gently push the licence plate bracket into position as shown in picture 31 and tighten the two bolts arrowed in pictures 32 and 33.
- Offer the support bracket (item 4) into position as shown in picture 34 and secure in place using the two remaining M6 bolts and washers (items 2 and 3) as shown in picture 35.
- Use the M5 bolt with washer (items 5 and 6) to secure the support bracket to the licence plate bracket as shown in picture 36.
- **IMPORTANT: IF FITTING A FULL-SIZE LICENCE PLATE AND PLACING IT FAR DOWN ON THE LICENCE PLATE HANGER, THERE IS A SMALL CHANCE OF THE LICENCE PLATE HITTING THE BACK WHEEL UNDER HEAVY LOAD AND OVER LARGE BUMPS IN THE ROAD. IT IS YOUR RESPONSIBILITY TO CHECK FOR THIS POSSIBILITY AND TAKE AVOIDING ACTION. FAILURE TO CHECK THIS COULD RESULT IN SERIOUS INJURY.**
- Refit the seat unit and licence plate (it may require drilling).
- Depending on local laws, attach enclosed reflector (item 13) in an appropriate location.
- **Please test the indicators, rear light and licence plate illuminator before riding.**

ISSUE 1 27/04/2016 (NSY)

CONSUMER NOTICE

The catalogue description and any exhibition of samples are only broad indications of the Products and R&G may make design changes which do not diminish their performance or visual appeal and supplying them in such state shall conform to the order. The Buyer acknowledges no representation or warranty (other than as to title) has been given or will apply to the Products other than those in R&G's order or confirmation and the Buyer confirms it has chosen the Products as being of merchantable quality

R&G Racing

Unit 1, Shelley's Lane, East Worldham, Alton, Hampshire, GU34 3AQ

Tel: +44 (0)1420 89007 Fax: +44 (0)1420 87301 www.rg-racing.com Email: info@rg-racing.com



LP0196

and suitable for its particular purposes. Where R&G fits the Products or undertakes other services it shall exercise reasonable skill and care and rectify any fault free of charge unless the workmanship has been disturbed. The Buyer is responsible for ensuring that the warranty on the motorcycle is not affected by the fitting of the Products. On return of any defective Products R&G shall at its option either supply a replacement or refund the purchase money but shall not be liable if the Products have been modified or used or maintained otherwise than in accordance with R&G's or manufacturer's instructions and good engineering practice or if the defect arises from accident or neglect. Other than identified above and subject to R&G not limiting its liability for causing death and personal injury, it shall not be liable for indirect or consequential loss and otherwise its liability shall be limited to the amounts paid by the Buyer for the Products or the fitting or service concerned. These terms do not affect the Buyer's statutory rights.

Page | 11

R&G RACING RETURNS POLICY (NON-FAULTY GOODS)

Returns must be pre-authorized (if not pre-authorized the return will be rejected). Goods may only be returned direct to us if they were purchased direct from us (customer must prove if necessary). Otherwise to be returned to original vendor. Goods must be in re-sellable condition, in the opinion of R&G Racing. All returns are subject to a 25% restocking and handling fee (25% of the gross value exc. P&P – at the prevailing price at time of purchase). The customer must pay any and all carriage charges. No returns of discontinued products, unless within 14 days of purchase. This policy does not affect your statutory rights and does not refer to faulty goods.

R&G Racing

Unit 1, Shelley's Lane, East Worldham, Alton, Hampshire, GU34 3AQ

Tel: +44 (0)1420 89007 Fax: +44 (0)1420 87301 www.rg-racing.com Email: info@rg-racing.com



LP0196

NOTICE DE MONTAGE POUR LP0196BK SUPPORT DE PLAQUE
HUSQVARNA 701 ENDURO/SUPERMOTO 2016-

Page | 12



Le kit contient les articles exposés ci-dessous, vérifier que toutes les pièces soient présentes avant de procéder au montage.

LA FAÇON DONT LE KIT EST EMBALLE NE CORRESPOND PAS FORCEMENT A LA FAÇON DE MONTER LES PIÈCES SUR LA MOTO

LES PARTIES PRESENTÉES PEUVENT ÊTRE UNIQUEMENT REPRESENTATIVES (POUR LA CLARTE DES INSTRUCTIONS UNIQUEMENT)

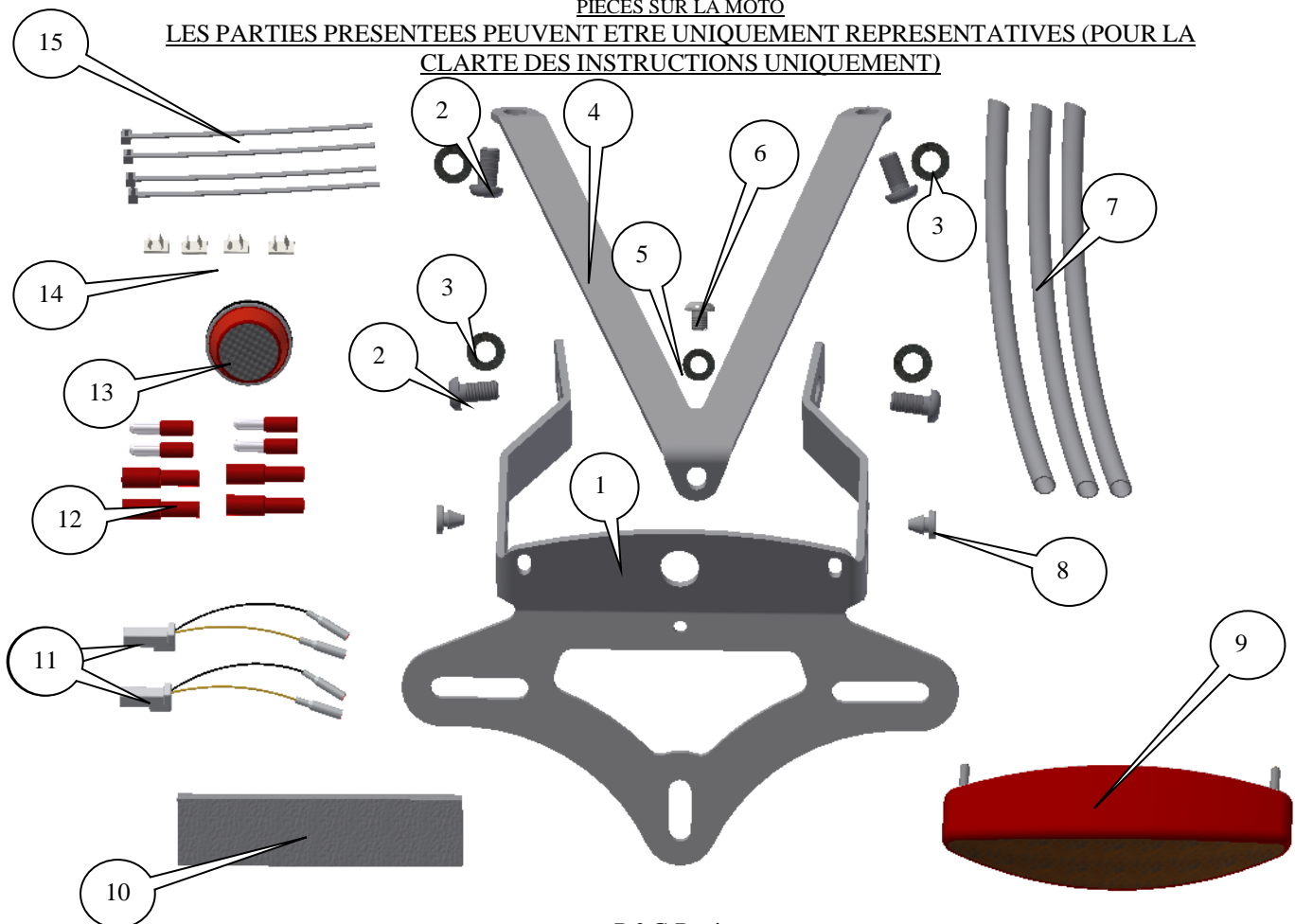

R&G Racing

Unit 1, Shelley's Lane, East Worldham, Alton, Hampshire, GU34 3AQ

Tel: +44 (0)1420 89007 Fax: +44 (0)1420 87301 www.rg-racing.com Email: info@rg-racing.com



LP0196

Page | 13

LEGENDE

- ARTICLE 1 = SUPPORT DE PLAQUE PRINCIPAL (TB0196 PARTIE 1) (x1).
ARTICLE 2 = BOULON M6 x 12mm (x4).
ARTICLE 3 = RONDELLES M6 (x4).
ARTICLE 4 = SUPPORT DE PLAQUE (TB0196 PART 2) (x1).
ARTICLE 5 = RONDELLES M5 (x1).
ARTICLE 6 = BOULON M5 x 6mm (x1).
ARTICLE 7 = LONGUEUR DE THERMO RETRACTABLE 150mm (x3).
ARTICLE 8 = OEILLETS CAOUTCHOUC RB50-20-00FG (x2)
ARTICLE 9 = ASSEMBLAGE FEU ARRIERE LA0005 (ROUGE) (x1).
ARTICLE 10 = MOUSSE AUTOCOLLANTE 150mm (x1).
ARTICLE 11 = CONNECTEURS CLIGNOTANTS (CON0014) (x2).
ARTICLE 12 = CONNECTEURS FEU ARRIERE (CON0004) (x2).
ARTICLE 13 = REFLECTEUR (REFL 1) (x1).
ARTICLE 14 = CLIPS CABLE AUTOCOLLANTS (x4).
ARTICLE 15 = PETITS COLLIERS DE SERRAGE (x2).

Notez que si les kits sont emballés avec des rondelles en caoutchouc servant à tenir les composants, *ces rondelles doivent être jetées !*

OUTILS REQUIS

- Clés Allen 3 et 4mm.
- Clé Torx T30.
- Clé à molette 13mm
- Un peu de superglue.

Notice disponible sur www.rg-racing.com

COUPLES DE SERRAGE RECOMMANDÉS :

M4 BOULON = 8Nm
M5 BOULON = 12Nm
M6 BOULON = 15Nm
M8 BOULON = 20Nm
M10 BOULON = 40Nm



LP0196

NOTICE DE MONTAGE

- Enlever le siège à l'aide du tire-câble (photo 1) et en décliquetant les 2 faussets indiqués sur les photos 2 et 3.
- Enlever les 4 boulons (photos 4 et 5) et abaisser le sous-plateau du support de plaque, voir photo 6.
- Déconnecter la prise de feu de plaque, voir photo 6 et enlever le sous-plateau du support de plaque.
- Enlever les 6 boulons, voir photos 7, 8, 9 et 10.
- Enlever le bouchon d'essence, voir photo 11.
- Enlever le capot arrière, voir photo 12 et remettre le bouchon d'essence jusqu'à ce qu'il soit prêt pour le réassemblage.
- Enlever les colliers de serrage et déconnecter le feu arrière et les prises de clignotants, voir photos 13 et 14 (*Il est judicieux de noter les correspondances entre connecteurs pour faciliter le remontage*).
- Enlever les 2 boulons, voir photos 15 et 16 puis enlever le support de plaque d'origine.
- Si vous souhaitez réutiliser les clignotants d'origine, enlever l'écrou de fixation du clignotant, voir photo 17 puis monter le nouveau support de plaque (article 1) voir photo 18 (répéter du coté opposé en notant de quel coté ils ont été enlevés).
- Si vous montez les mini clignotants de votre choix sur le nouveau support de plaque (article 1) (mini clignotant R&G code RG370 pour type ampoule et RG371 pour type LED ou RG372 pour type LED latéral) voir photo 19 (Utiliser la thermo rétractable fournie (article 7) pour protéger les fils). *Si vous montez les mini clignotants R&G, utiliser les 2 oeillets de caoutchouc (article 8) pour boucher les trous non utilisés (photos 19 et 20).*
- Prendre le support de plaque R&G (article 1) et monter le nouveau feu arrière (article 9), voir photos 19 et 20 (une option « lentille claire » est disponible à l'achat – code produit LA0003). (Utiliser la gaine thermo rétractable (article 7) pour protéger le nouveau fil de feu arrière).
- Couper à la bonne longueur et coller le bandeau de mousse (article 10) sur le bord supérieur du feu, voir photos 21 et 22.
- Monter l'assemblage de support de plaque au dessous de l'unité de support de plaque (voir photos 23, 24 et 25) et utiliser 2 des boulons M6 avec rondelles (articles 2 et 3) pour fixer la position, voir photos 23, 24 et 25 (ne pas serrer les boulons complètement pour le moment).
- Connecter les prises de clignotant (telles qu'elles ont été marquées précédemment) (Si vous utilisez les mini clignotants R&G, utilisez les 2 connecteurs (article 11= ceux qui ont 2 fils) pour connecter le faisceau principal, voir photo 26.
- Si le clignotant ne fonctionne pas, tournez les connecteurs. Svp, utilisez les colliers de serrage et les clips autocollants pour serrer et fixer les fils.
- Utiliser les connecteurs en forme de bloc de scotch pour rattacher les fils de feu arrière comme détaillé ci-dessous et indiqué au verso.

FILS D'ORIGINE-----FILS R&G
VERT-----NOIR=TERRE/RETOUR
JAUNE----- ROUGE=FEU STOP
FEU MARRON/ORANGE----- JAUNE=FEU LATERAL ET FEU DE PLAQUE

R&G Racing

Unit 1, Shelley's Lane, East Worldham, Alton, Hampshire, GU34 3AQ
Tel: +44 (0)1420 89007 Fax: +44 (0)1420 87301 www.rg-racing.com Email: info@rg-racing.com

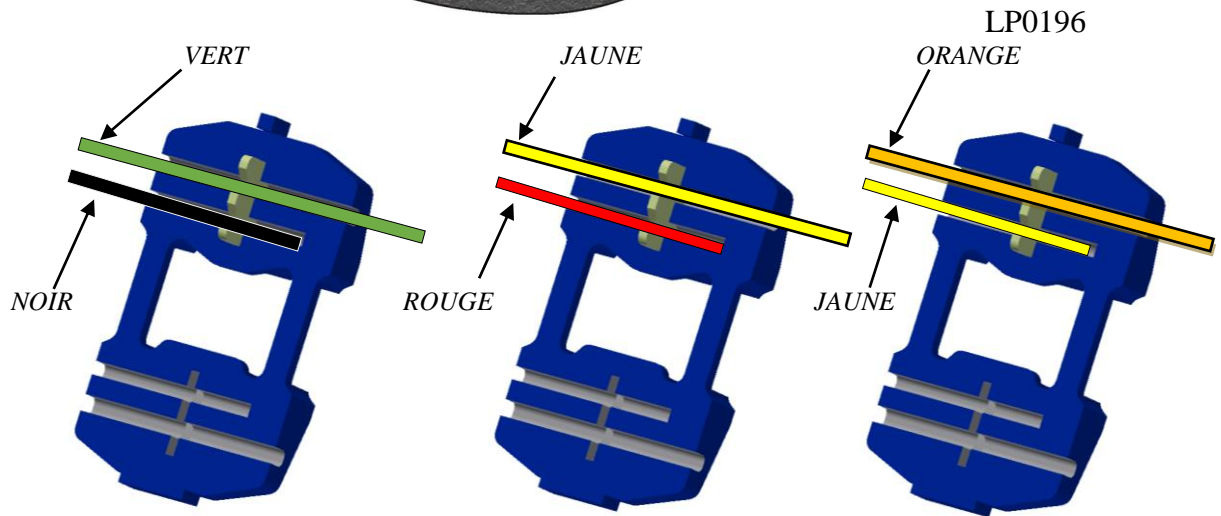

- Vous pouvez également couper puis fermer la prise d'origine du feu arrière à l'aide des connecteurs (article 12) comme détaillé ci-dessous.
- Prendre le feu d'origine avec le connecteur, et couper les fils à environ 4cm du connecteur. Dénudez les extrémités des 3 fils et monter 3 connecteurs mâle fournis (article 12 – CON0004).
- Connecter les 3 connecteurs femelle sur le nouveau fil de feu et connecter comme indiqué ci-dessus. Reconnecter la prise de feu arrière, il est judicieux de tester les clignotants et le feu arrière à ce stade. Si un feu ne s'allume pas, tournez les connecteurs. Utilisez les colliers de serrage et clips autocollants fournis pour fixer les fils.
- Enlever le bouchon d'essence et remonter le capot arrière comme à l'origine, voir photo 27.
- Remettre le bouchon d'essence, voir photo 28.
- Réinsérez les boulons d'origine pour fixer le capot arrière, voir photos 9, 29 et 30 comme à l'origine (les 2 boulons indiqués sur la photo 10 ne sont pas réutilisés).
- Placer le support de plaque en position, voir photo 31 puis serrer les 2 boulons indiqués sur les photos 32 et 33.
- Monter le support de plaque (article 4) en position, voir photo 34 et fixer la position à l'aide des 2 boulons M6 restants et des rondelles (articles 2 et 3) voir photo 35.
- Utiliser le boulon M5 avec rondelle (articles 5 et 6) pour fixer le support sur le support de plaque, voir photo 36.
- **IMPORTANT: Si vous installez une grosse plaque, il y a un risque que la plaque entre en contact avec la roue arrière en cas de choc sur la route (bosse, grosse charge etc...). Il est de votre responsabilité de vérifier que cela ne puisse pas se produire. Ne pas effectuer ces vérifications peut entraîner des dommages ainsi que des blessures graves pour le pilote.**
- Remettre le siège et la plaque (peut nécessiter un perçage).
- Selon la loi locale, attachez le réflecteur (article 13) fourni à son emplacement approprié
- **Vérifiez que les clignotants et les feux de plaque fonctionnent bien avant de prendre la route.**

ISSUE 1 27/04/2016 (NSY)



LP0196

CONSUMER NOTICE

The catalogue description and any exhibition of samples are only broad indications of the Products and R&G may make design changes which do not diminish their performance or visual appeal and supplying them in such state shall conform to the order. The Buyer acknowledges no representation or warranty (other than as to title) has been given or will apply to the Products other than those in R&G's order or confirmation and the Buyer confirms it has chosen the Products as being of merchantable quality and suitable for its particular purposes. Where R&G fits the Products or undertakes other services it shall exercise reasonable skill and care and rectify any fault free of charge unless the workmanship has been disturbed. The Buyer is responsible for ensuring that the warranty on the motorcycle is not affected by the fitting of the Products. On return of any defective Products R&G shall at its option either supply a replacement or refund the purchase money but shall not be liable if the Products have been modified or used or maintained otherwise than in accordance with R&G's or manufacturer's instructions and good engineering practice or if the defect arises from accident or neglect. Other than identified above and subject to R&G not limiting its liability for causing death and personal injury, it shall not be liable for indirect or consequential loss and otherwise its liability shall be limited to the amounts paid by the Buyer for the Products or the fitting or service concerned. These terms do not affect the Buyer's statutory rights.

Page | 16

R&G RACING RETURNS POLICY (NON-FAULTY GOODS)

Returns must be pre-authorized (if not pre-authorized the return will be rejected). Goods may only be returned direct to us if they were purchased direct from us (customer must prove if necessary). Otherwise to be returned to original vendor. Goods must be in re-sellable condition, in the opinion of R&G Racing. All returns are subject to a 25% restocking and handling fee (25% of the gross value exc. P&P – at the prevailing price at time of purchase). The customer must pay any and all carriage charges. No returns of discontinued products, unless within 14 days of purchase. This policy does not affect your statutory rights and does not refer to faulty goods.

R&G Racing

Unit 1, Shelley's Lane, East Worldham, Alton, Hampshire, GU34 3AQ

Tel: +44 (0)1420 89007 Fax: +44 (0)1420 87301 www.rg-racing.com Email: info@rg-racing.com