

50-0640 Ducati 1098 Assembly Instructions

1) Place the tube clamps around the frame tube with the threaded portion towards the motor.

IMPORTANT NOTE: The frame tube is not parallel to the main bracket, it gets closer to the bracket as you move away from the main frame bolt. The tube clamps must be oriented such that the 8 x 35 bolts run parallel with the main 12mm motor mount bolts and the tube clamps are perpendicular to the Main Support Bracket.
Warning - improper installation will damage your frame.

2) Pass the (2) 8 x 35 bolts through the main bracket and through the unthreaded portion of the clamp. Then screw the bolts into the threaded portion of the clamp 4-5 revolutions (leave loose at this point).

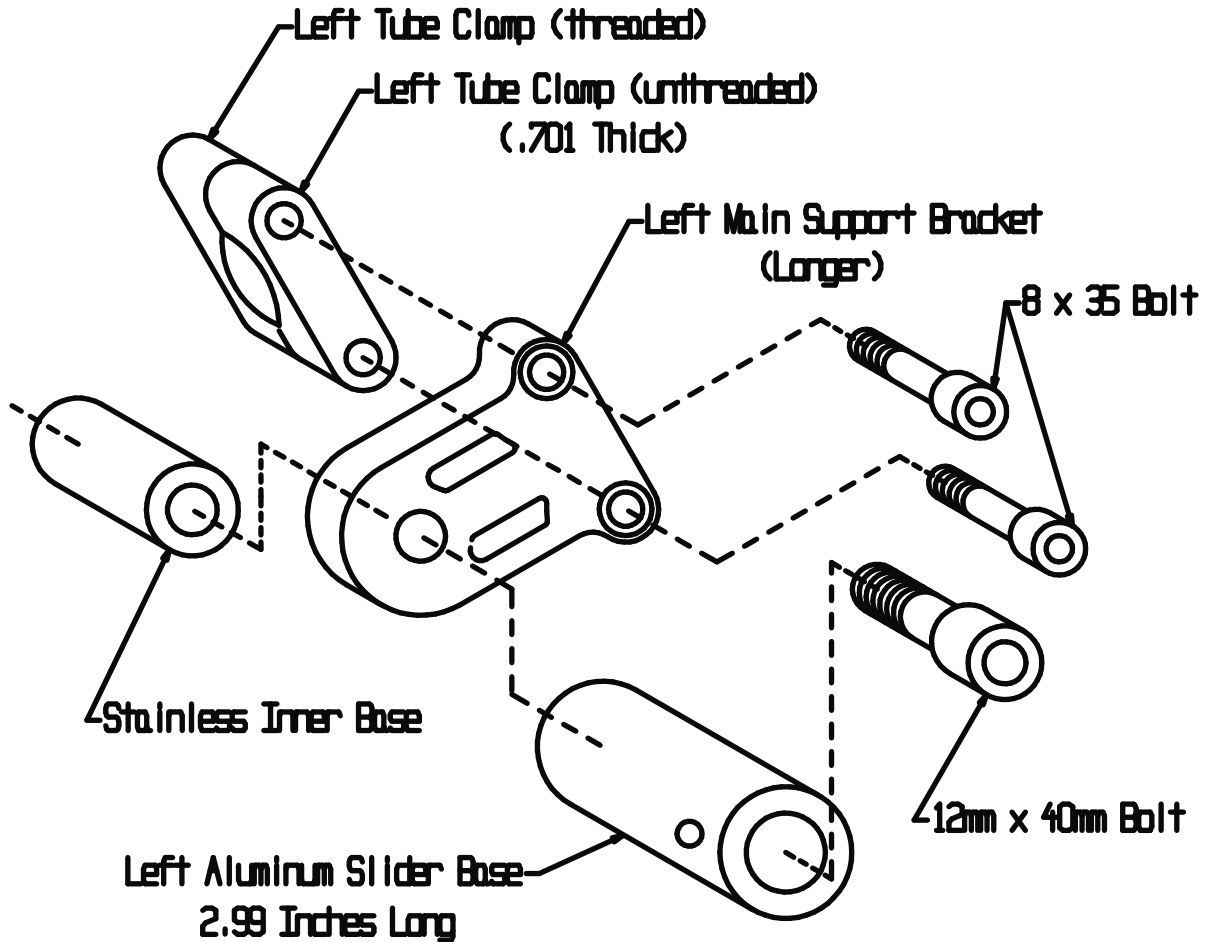

3) Pass the 12 x 40mm bolt through the Slider Base, through the Main Support Bracket and thread it into the Stainless Inner Base until the bolt is snug (do not torque yet).

4) Repeat Steps 1 & 2 for the Right Hand Slider Assembly

5) Pass the 12 x 300mm bolt through the Right Slider Base, through the Right Main Support Bracket, through the Aluminum inner base and thread it into the Stainless Inner Base until the bolt is snug (do not torque yet).

6) Now that the main 12mm bolts are snug, tighten the 8 x 35mm bolts on each side. Be sure again that the tube clamps are oriented properly and the Tube Clamp is perpendicular to the Main Support Bracket before tightening these bolts. Once this is checked, torque these bolts in place.

7) Re-fit the fairings by hand so that you can trace the circle for the center of the hole needed for the sliders. You will need to cut a 2" hole for the sliders. We suggest drilling a very small pilot hole in the center of the circle and then fitting the bodywork again to be sure that the hole is in the center of the bodywork. If you are not confident, we suggest drilling a smaller hole and then opening it up little by little with a drum sander (using a dremel tool with a large diameter sanding drum). This will allow you to open the hole with maximum control

8) 2 people required. Torque the main engine mounting bolt. One person should have a socket to hold one bolt and the other should torque the opposite side with a torque wrench. The person with the torque wrench should torque both sides of the bolt.

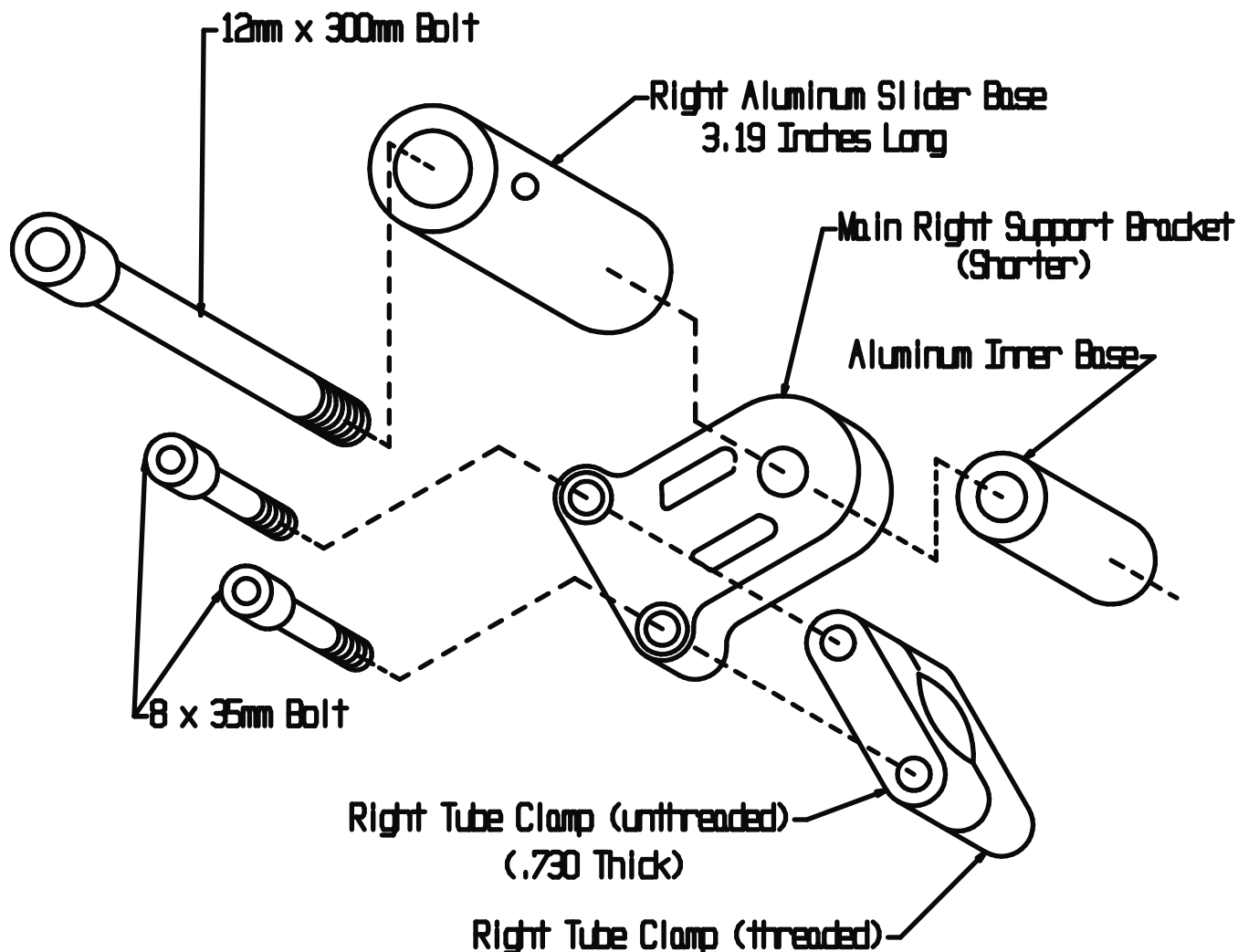

9) Slide the plastic slider over the top of the base on and secure in place using the 8mm countersunk bolt. The bolt passes first through the non threaded hole and then screws into the threaded hole on the far side of the base. The plastic is undersized on the far side of the slider to act as a locknut for the bolt

10) Remount the bodywork.