

!!! WARNING !!!

This is an aftermarket part built for racing purposes only.

Koso is not responsible for any damages caused to the parts, vehicle, or to yourself and others.

Engine parts are not under warranty nor is collateral damage or cost of labor, in cases of malfunction.



● Thanks for purchasing our MSX 61mm ceramic coated cylinder with Forged Piston. In order to install this kit properly, please read carefully these instruction sheets and retain them for future reference.

⚠ Precautions

1. This product should be installed by professional mechanics only. To avoid damages to the engine, follow carefully the instruction bellow. Wrong installation and damages to the engine shall be inputed to the user.
2. Always use the proper tools to take appart and assemble the engine.
3. Do not attempt to take appart or assemble the engine using any other method than the one describe in these instruction sheets.
4. The internal inspection or the maintenance of this kit should be performed by professional mechanics only.

© Description of symbols

- Engine oil must be used during installation.
- Torque value required for fastening the screws.
- Certain procedures must be followed in order to insure the proper installation of the components.
- WARNING!** Certain procedures must be followed to avoid injuries to the user or others.
- CAUTION!** Certain procedures must be followed to avoid damages to the vehicle.

1 Accessories

1 Ceramic Coated Cylinder x 1	2 Cylinder Upper Gasket x 1	3 Cylinder Lower Gasket x 1	4 Piston x 1	5 Piston Ring x 1 set
6 Piston Pin x 1	7 C-Ring x 2	8 M10 x 1.25mm x 20mm Oil Banjo bolt x 2	9 Washer x 2	

NOTE Please contact your local distributor if the items received are not the same as the one listed above.

2-1 Gear Timing Adjustment

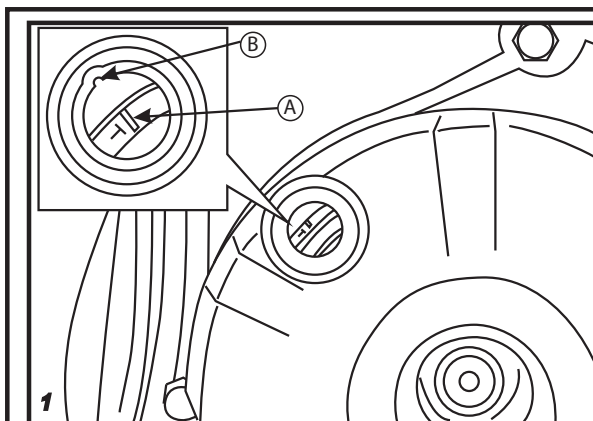

1. Remove the ignition timing cap. Using the proper tool, rotate the flywheel until the TDC mark (A) is properly aligned with the timing mark (B) on the crank cover.
2. Confirm the engine timing is correct by checking if the mark on the camshaft (C) is correctly aligned with the mark on the cylinder head (D).

NOTE When installing the camshaft, make sure the chain is always tense.

⚠ CAUTION! When taking apart the engine, make sure to adjust the timing gear properly before proceeding with the dismantling operation.

⚠ CAUTION! To avoid changing the value or causing timing error of the valves, do not attempt to turn the crank while working on the engine.

⚠ WARNING! Following the installation of the timing gear and chain, check if the timing marks are still aligned correctly. Before starting the engine, perform with a cold test by turning manually the crank to prevent any damages that could be cause to the engine.

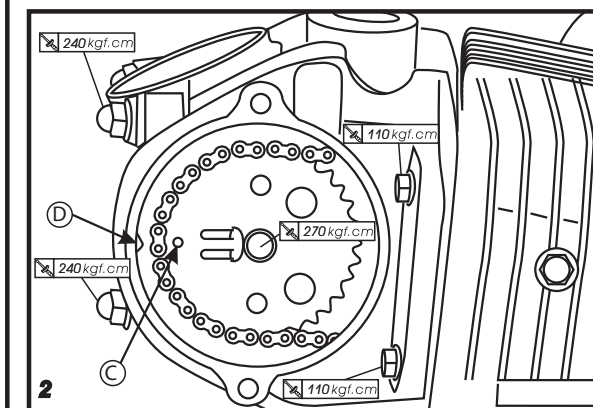

2-2 Cylinder and Piston Disassembly

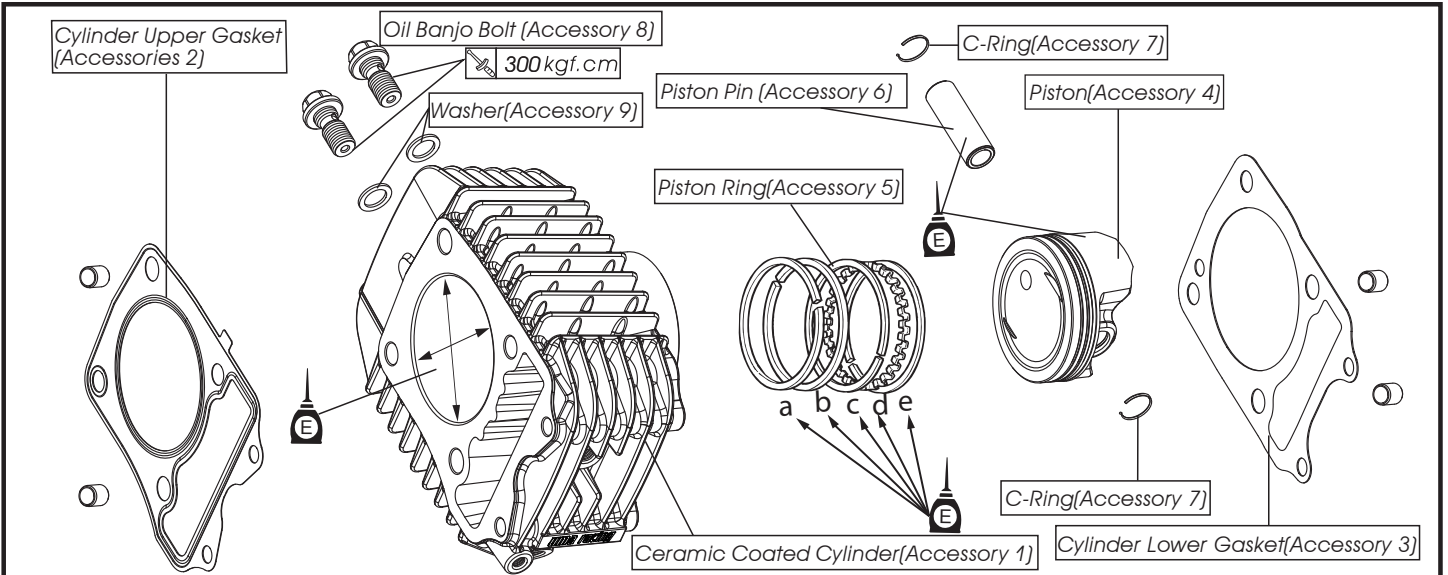

⚠ Remove the entire top end of the engine in order to facilitate the replacement of the cylinder.

⚠ Before installing the cylinder, apply lubricant oil on the cylinder sleeve to avoid scratching or damaging the cylinder or piston.

NOTE Disassemble the engine according to the steps above. The installation of the cylinder and piston should be performed in reverse sequence.

NOTE Apply engine oil on the original factory dowel pin .

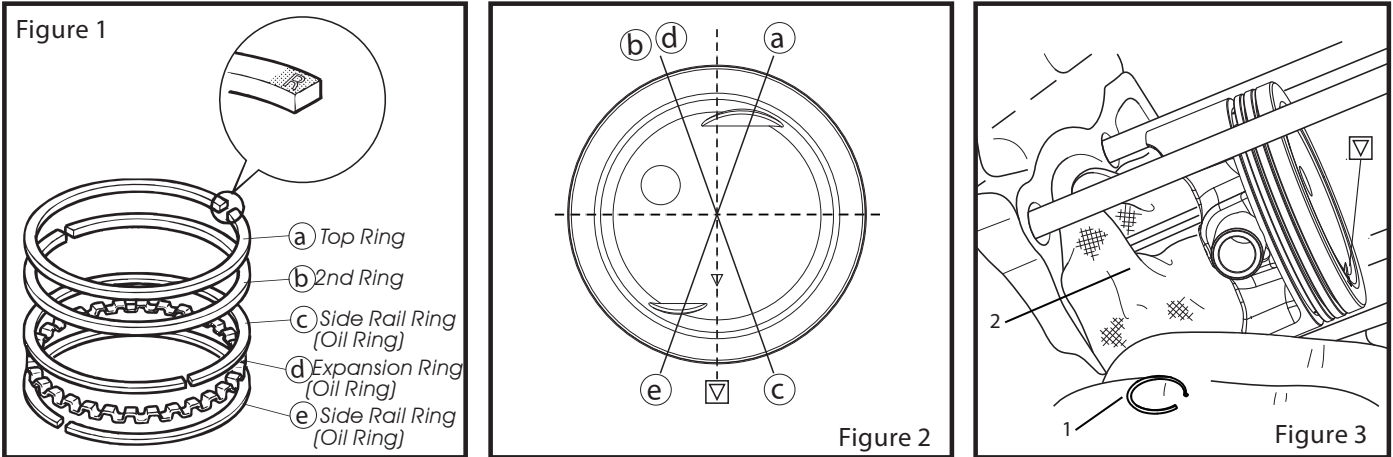

⚠ The marking on the piston ring should face upward (Fig. 1) and the gap on the Piston Ring should NOT be aligned when installed with each other when installed on the piston.

NOTE During the installation, confirm that the triangle marking on the piston is facing toward the exhaust side of the cylinder (Fig. 2).

⚠ **CAUTION!** During the installation of the piston, make sure to cover the opening of the crankcase in order to prevent anything from falling inside the engine base (Fig. 3).

3 Test Diagram

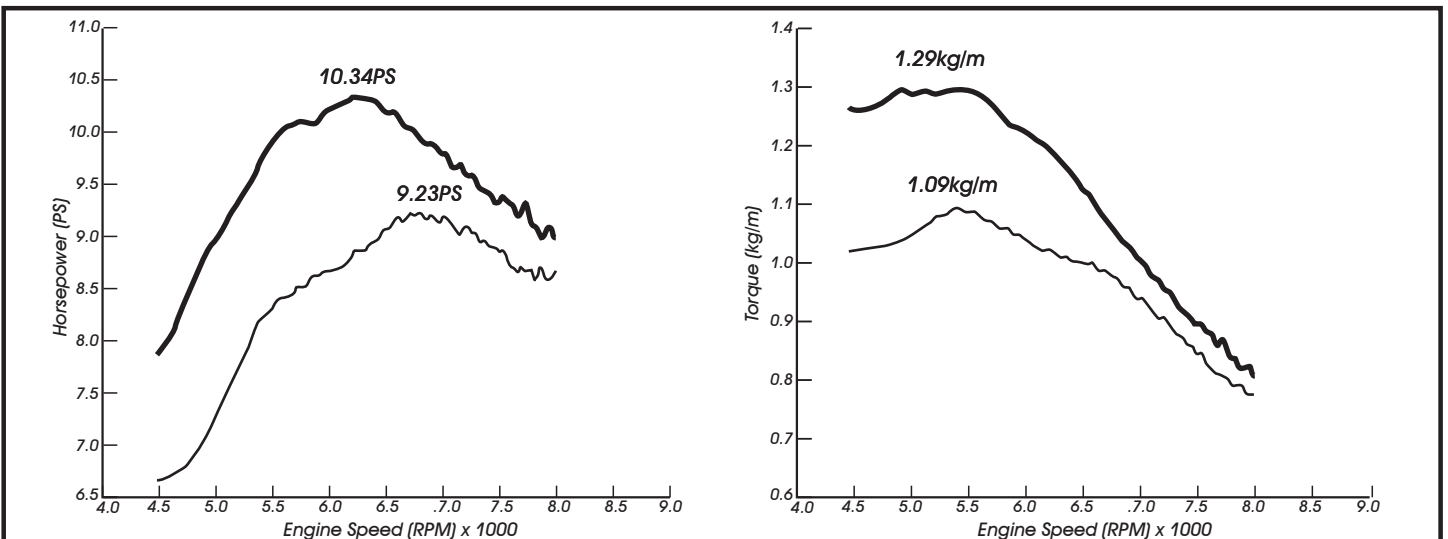

NOTE 61mm Ceramic Cylinder unit results are based on the original factory's setting (3-speed test).

NOTE The test result may vary due to the respective test environment and weather. This test diagram is provided for reference only.