

- I)_ **Attenzione!** Utilizzare lo scarico LeoVince in abbinamento alla mappa "Advanced".
- GB)_ **Warning!** Please use LeoVince Exhaust combined with the map "Advanced".
- F)_ **Attention!** Pour le correct fonctionnement de l'échappement LeoVince, sélectionner la cartographie "Advanced".
- D)_ **Achtung!** Bitte verwenden sie in Verbindung mit einem LeoVince ausschließlich die Map "Advanced".
- E)_ **Cuidado!** Para el correcto funcionamiento del escape LeoVince, seleccionar el mapa "Advanced".

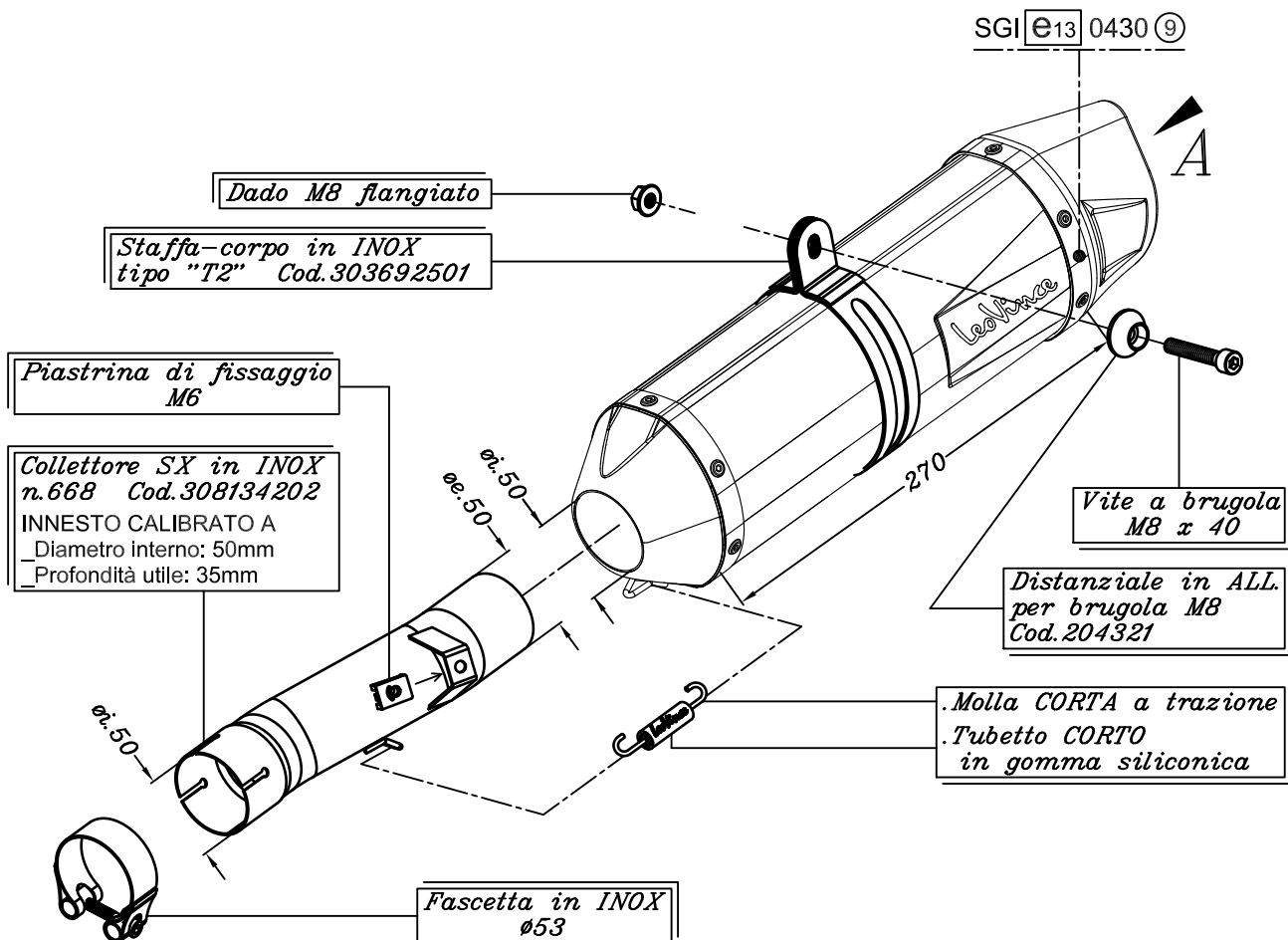

KTM 690 SMC i.e. ('08/'11)
 KTM 690 SMC R i.e. ('12)
 KTM 690 ENDURO i.e. ('08/'11)
 KTM 690 ENDURO R i.e. ('09/'12)

Art.8299E

Slip-on SBK "LV ONE EVO" – INOX – Passaggio
STANDARD OMOLOGATO "EVOLUTION II"