



REKLUSE[®]
RADIUS_x

REKLUSE MOTOR SPORTS

INSTALLATION GUIDE

Doc ID 191-6301
Revision 123016

OVERVIEW

- Read the separate included Safety Information document before operating the vehicle with the product installed.
- If you are performing the installation of this product for a customer or another person, instruct them to read the Safety Information document and the Installation and User Guide before operating the vehicle with the product.
- Read this entire document before performing any steps, so you will know what to expect.
- When reinstalling components, use the torque specifications found in your service manual. Torque values listed are valid as of the date shown in the document revision number above.
- Use clean, quality JASO MA or JASO MA2 certified oil

All OEM components will be reused except:

- This kit will replace all of the OEM frictions and drive plates with a Rekluse thin friction EXP clutch pack. Inspection of OEM components is necessary during installation
- This kit will replace the OEM pressure plate with a Rekluse pressure plate.
- This kit will replace the OEM slave cylinder with a Rekluse adjustable slave cylinder.

• **Tuning Note: (especially for 2-Stroke owners):**

- Upon installation of this product, if you desire your clutch to engage more aggressively, a favorable option is to purchase the heavier Belleville spring from KTM (KTM calls it the “280” spring).
- KTM Part #: 78932005000
- This spring will make the clutch engagement more aggressive but will slightly increase the clutch lever pull effort. This spring comes stock on 2013 and newer Factory Edition 450SX-F bikes.

©2016 Rekluse Motor Sports
Rekluse Motor Sports, Inc.
12000 W Franklin Rd.
Boise, ID 83709
208-426-0659
support@rekluse.com

INSIDE THIS DOCUMENT

- INSTALLATION TIPS
- TOOLS NEEDED
- INCLUDED PARTS
- INSTALLATION INSTRUCTIONS
 - CLUTCH DISASSEMBLY AND INSTALLATION
 - SLAVE CYLINDER DISASSEMBLY AND INSTALLATION
 - SETTING THE INSTALLED GAP
 - CHECKING FREE PLAY GAIN
 - FREE PLAY GAIN TROUBLESHOOTING
 - BREAK-IN PROCEDURE
- MAINTENANCE
- TROUBLESHOOTING GUIDE
 - FREE PLAY GAIN TROUBLESHOOTING
 - OPTIMIZING EXP ENGAGEMENT

INSTALLATION TIPS

- Protect eyes and skin – wear safety glasses and thin disposable work gloves.

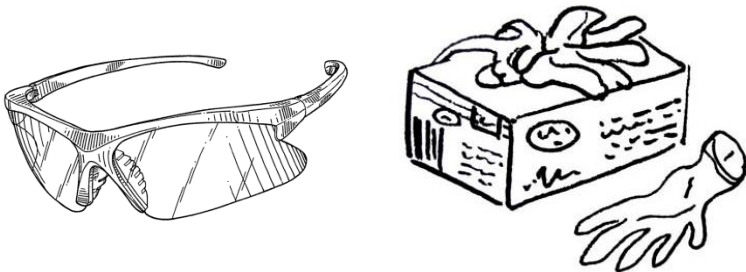

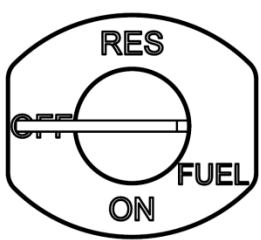

- Inspect your OEM cable for fraying and replace if needed.
- Work in a ventilated area.
- If the motorcycle is a two stroke turn the fuel petcock to “OFF.”



- During disassembly and installation lay the bike on its left side to avoid draining the oil. Do this by placing the handle bar on a center stand. Catch fuel that may drain from vent tubes.



TOOLS NEEDED

	 8 mm	 4mm		
Hydraulic Clutch Fluid	8mm socket	4mm Allen	Torque wrench	Metric End Wrench Set
		 T25	 T20	
Dental Pick	No Tools Required	Torx Bit T25	Torx Bit T20	

INCLUDED PARTS

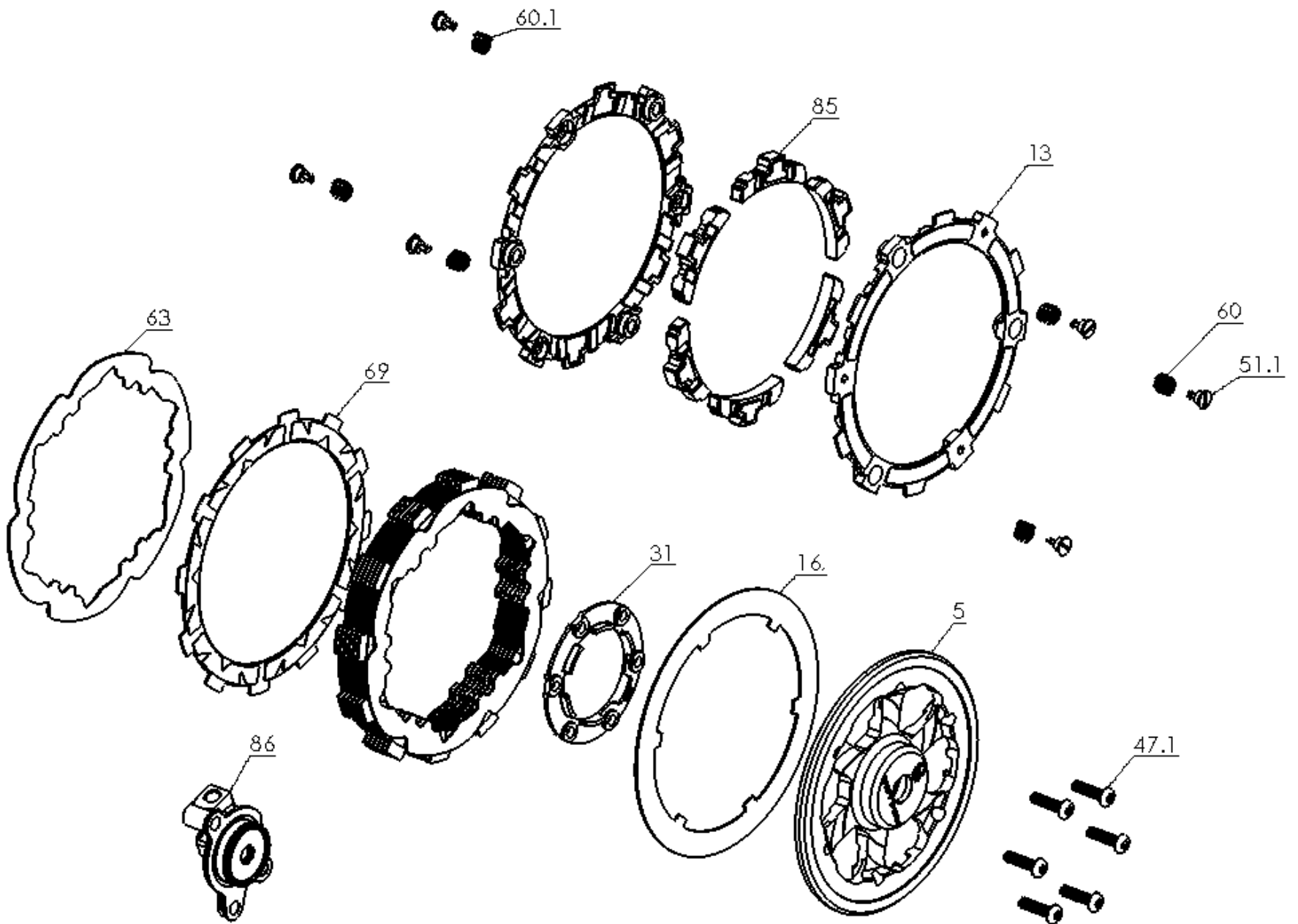

Item	Description	Qty.
5	Pressure Plate	5
13	EXP Base	2
16	Lining Plate	1
31	Pressure Ring Spacer	1
47.1	T-25 Torx Screw	6
51.1	Quarter Turn Pin	6
60	EXP Spring	3
60.1	EXP Spring	3
63	Drive Plate	8
69	Thin Friction Disk	7
85	Wedge Assembly	1
86	Adjustable Slave Cylinder	1
Not Shown	Spacing Gasket	*
Not Shown	Orange FPG Rubber Band	1
Not Shown	EXP Spares	6
Not Shown	Quarter Turn Pin Spares	2
*Parts are only included in products when required. If your kit does not have these part then they are not necessary for installation		

INSTALLATION INSTRUCTIONS

DISASSEMBLY AND INSTALLATION

1. Soak the EXP disk and Torqdrive friction disks in engine oil for 5 minutes.

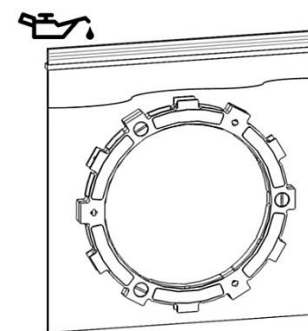

2. If your bike is carbureted, turn the fuel petcock to "OFF" and lay the bike on its left side.

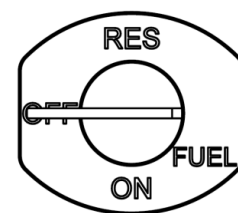

3. Remove the OEM clutch cover



8 mm



NOTICE

Take note of each OEM clutch cover bolts specific location as length can vary between them. Failure to replace these bolts in the proper location after clutch installation can result in damage to your motorcycle.

4. Remove the OEM parts named in the following diagram.
Note the orientation of the Belleville spring.



8 mm



NOTICE

Throwout washers can stick to the back of the pressure plate. Be sure to reindex any throwout washers back onto the throwout.

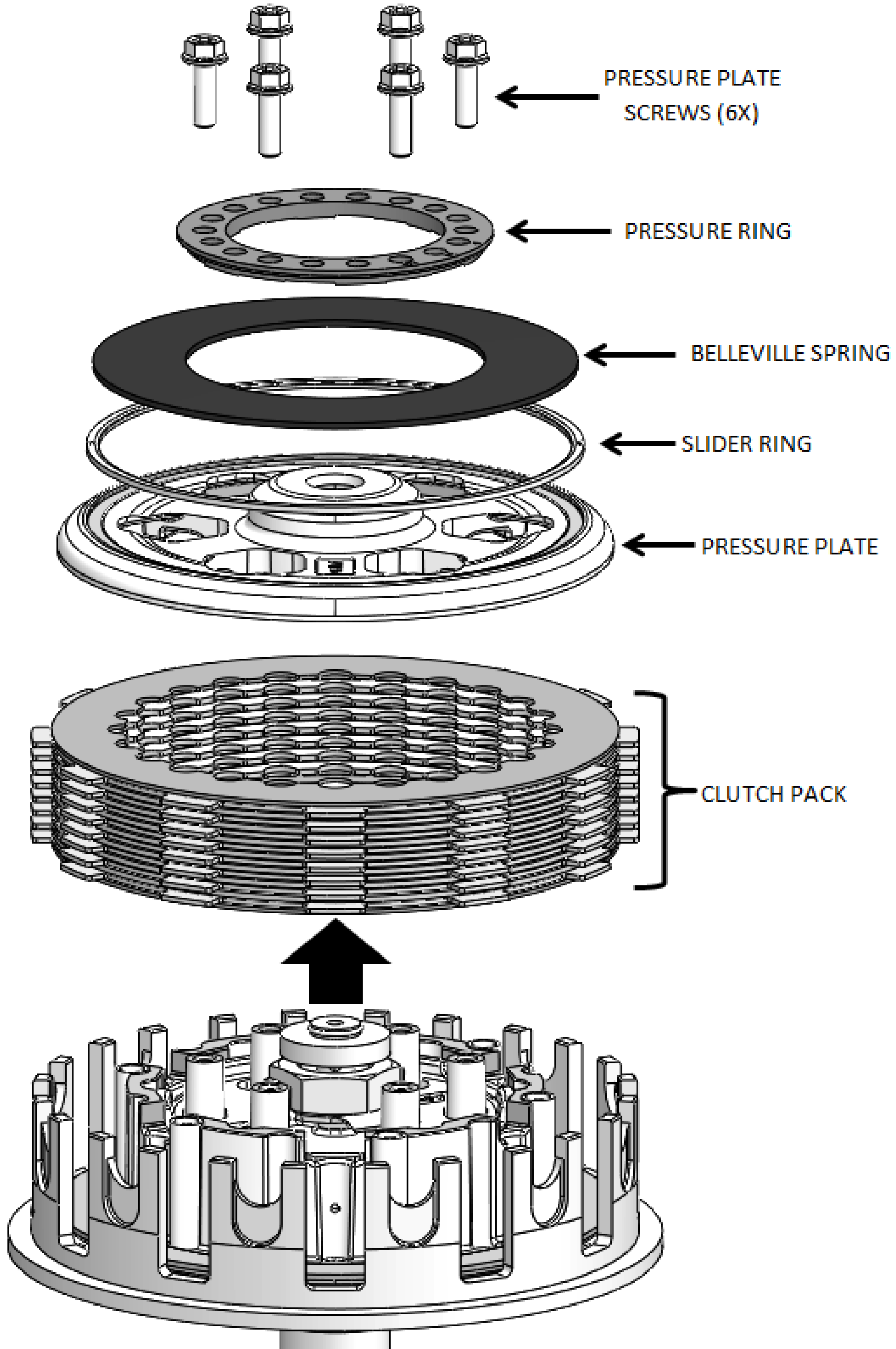

5. The KTM DDS clutch (a.k.a. Belleville spring clutch) employs a 2-piece damped center hub assembly, as shown. Rekluse clutch products employ the same technology and reuse the OEM rubber dampers.

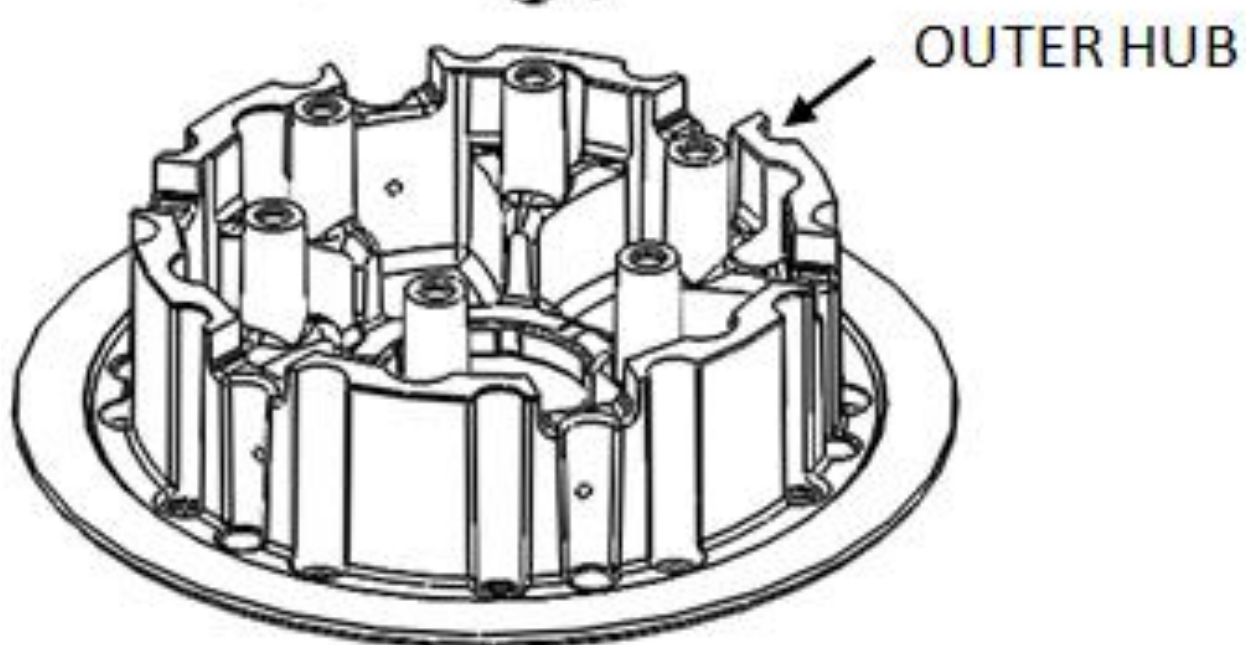
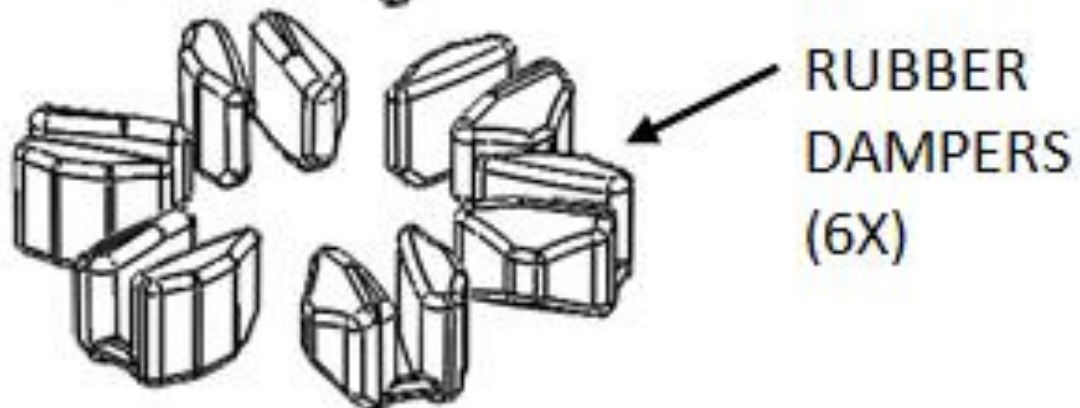
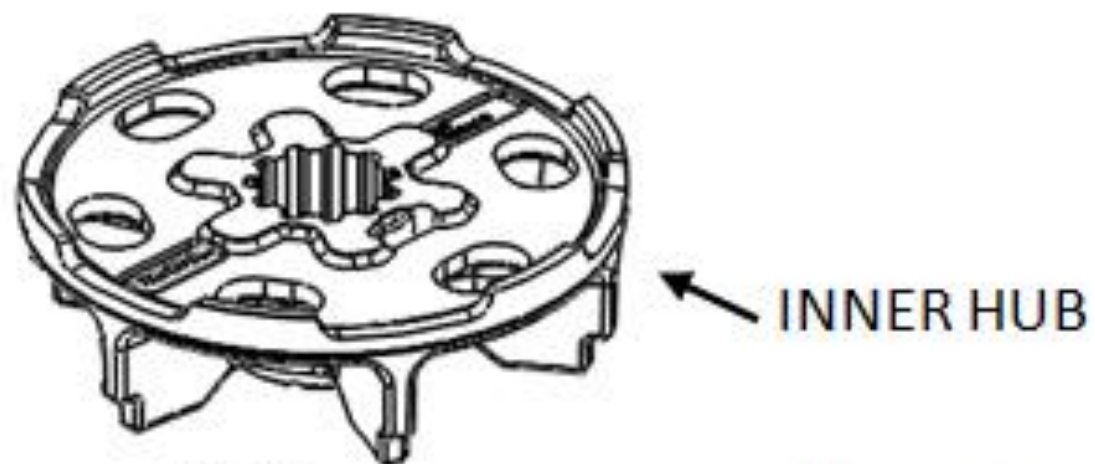
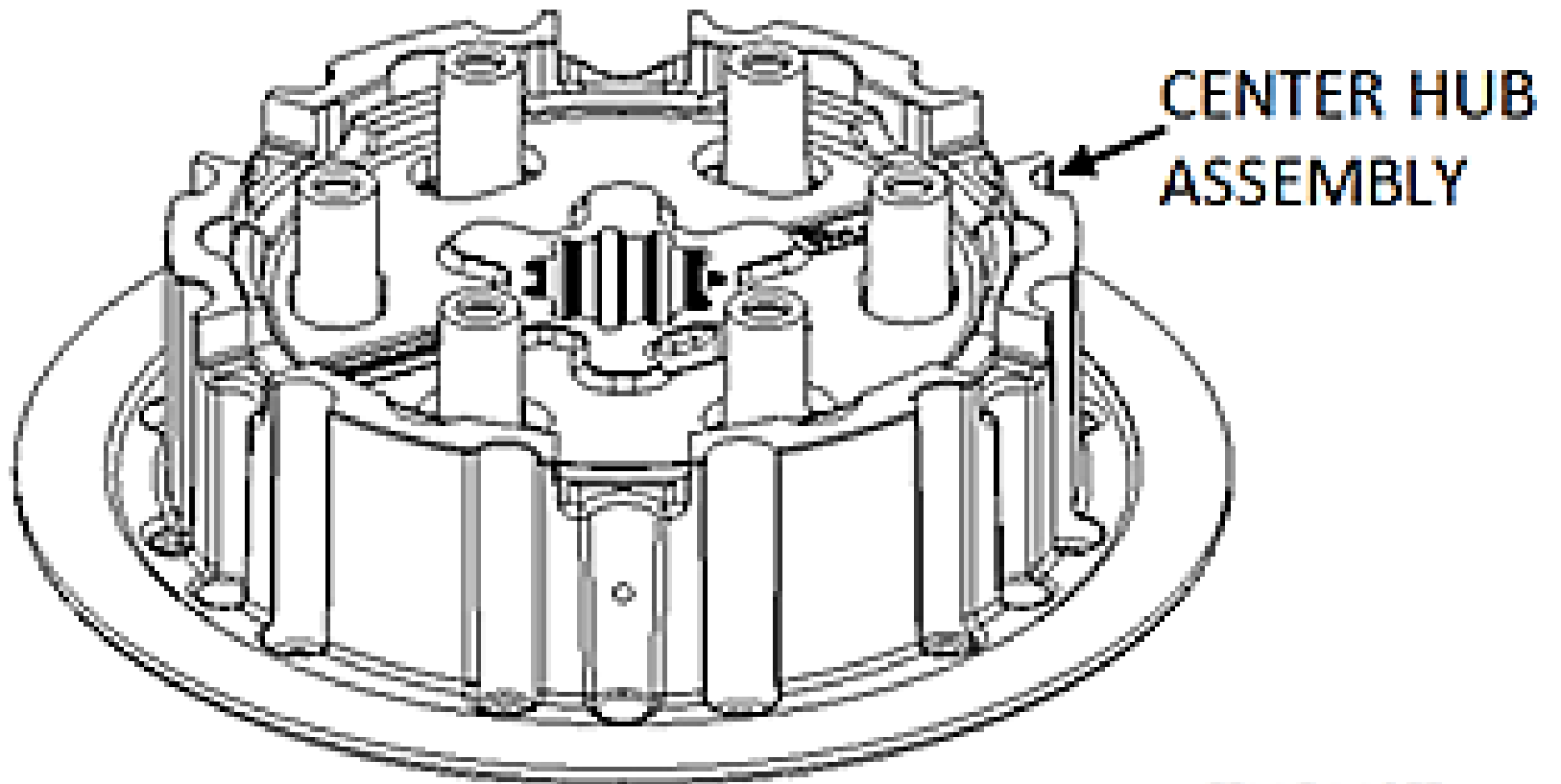

Over time, the rubber dampers will shrink due to heat and use. When this shrinkage occurs, the rotating action between the two hubs becomes loose or sloppy. This can cause hammering between the clutch parts which will reduce the life of the clutch.

KTM recommends inspecting the clutch every 20 bike hours for SX-F models, and every 30 hours for XC, EXC, and XC-W off-road models, and replacing components as necessary. Rekluse has found that these inspection intervals are typically consistent with the expected life of the rubber dampers.

For example: the 450 SX-F (including factory edition) engine operates at high temperatures, and its dampers will require servicing at about 20 hour intervals.

Rekluse recommends inspecting the rubber dampers before installing your new Rekluse clutch product. If your bike has reached or exceeded the recommended inspection interval before installation of this product, perform the clutch installation with **new** rubber dampers. After installation of your Rekluse clutch product, continue to inspect the dampers at these regular intervals and replace if necessary.

The rubber dampers = KTM part #: 78132025100 (6 are required)

With the bike in neutral, place your thumbs on the inner hub, at the location of the embossed part numbers, and try to spin the inner hub back and forth inside the outer hub. Rekluse recommends replacing the dampers if you feel slop between the two hubs.



6. Install the Rekluse clutch pack as seen in the configuration on the following page.

NOTICE

Proper orientation of the drive plates is critical for optimal clutch performance. If you install them backwards the clutch will still function but will lack proper modulation performance.

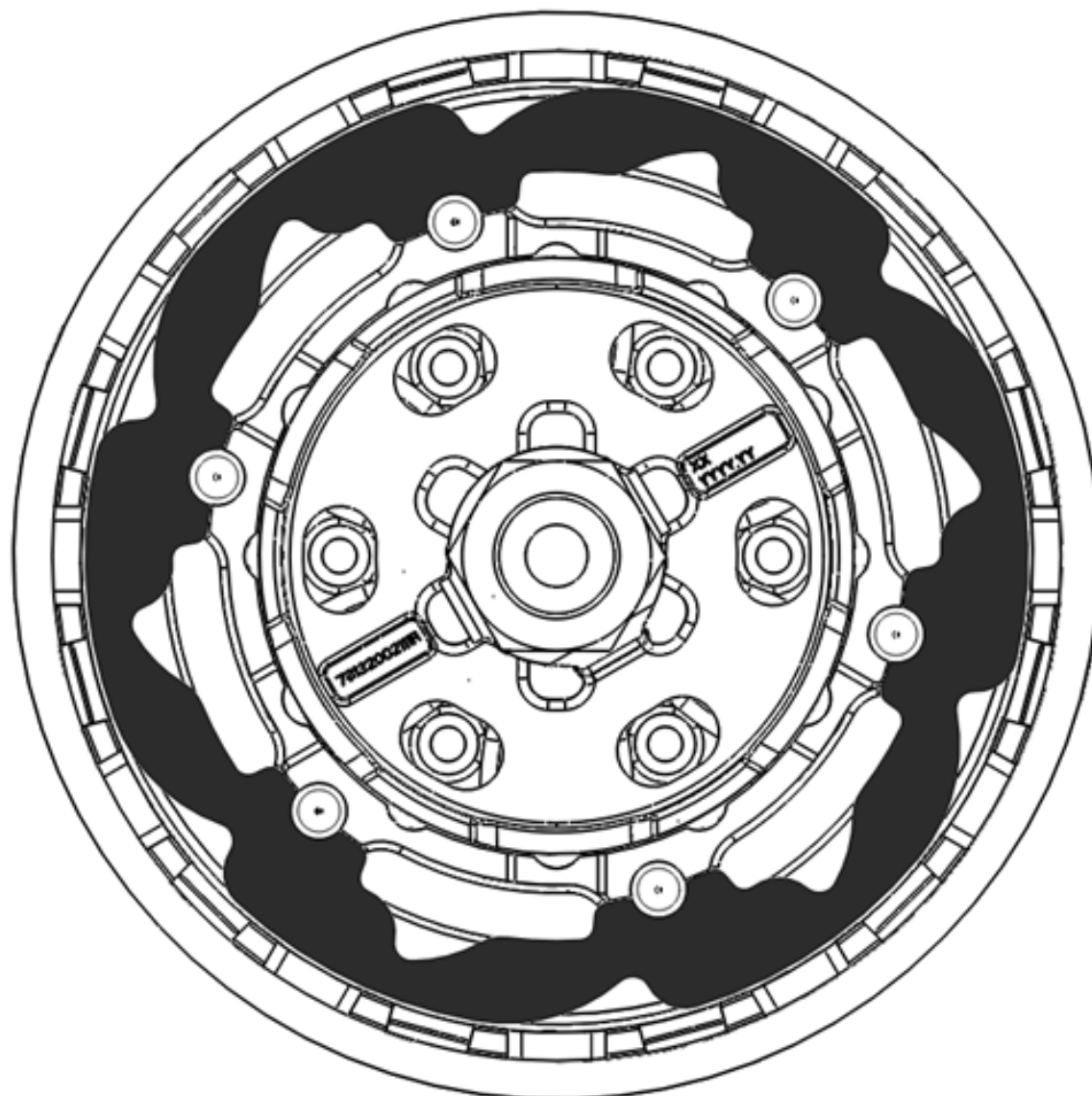
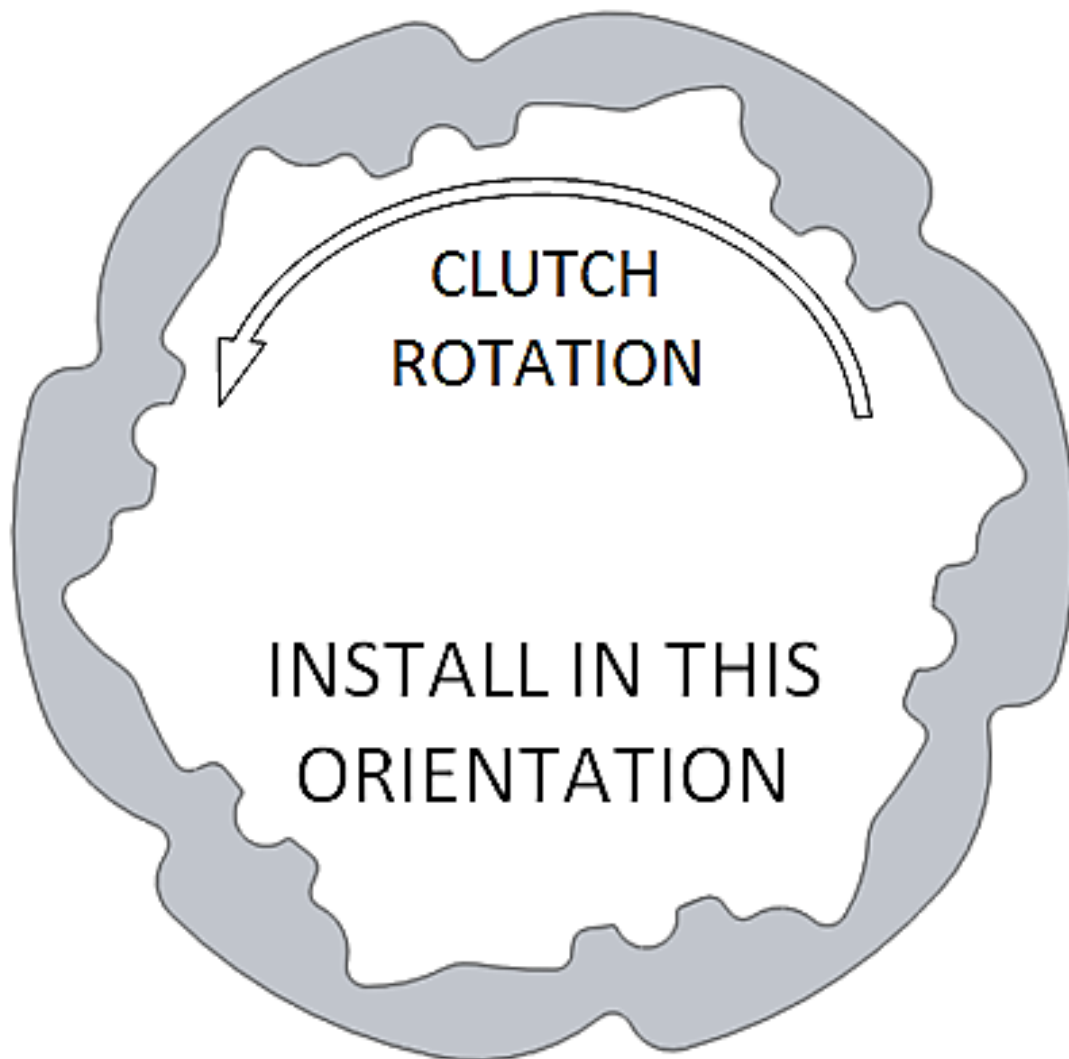

Clutch Pack Configuration

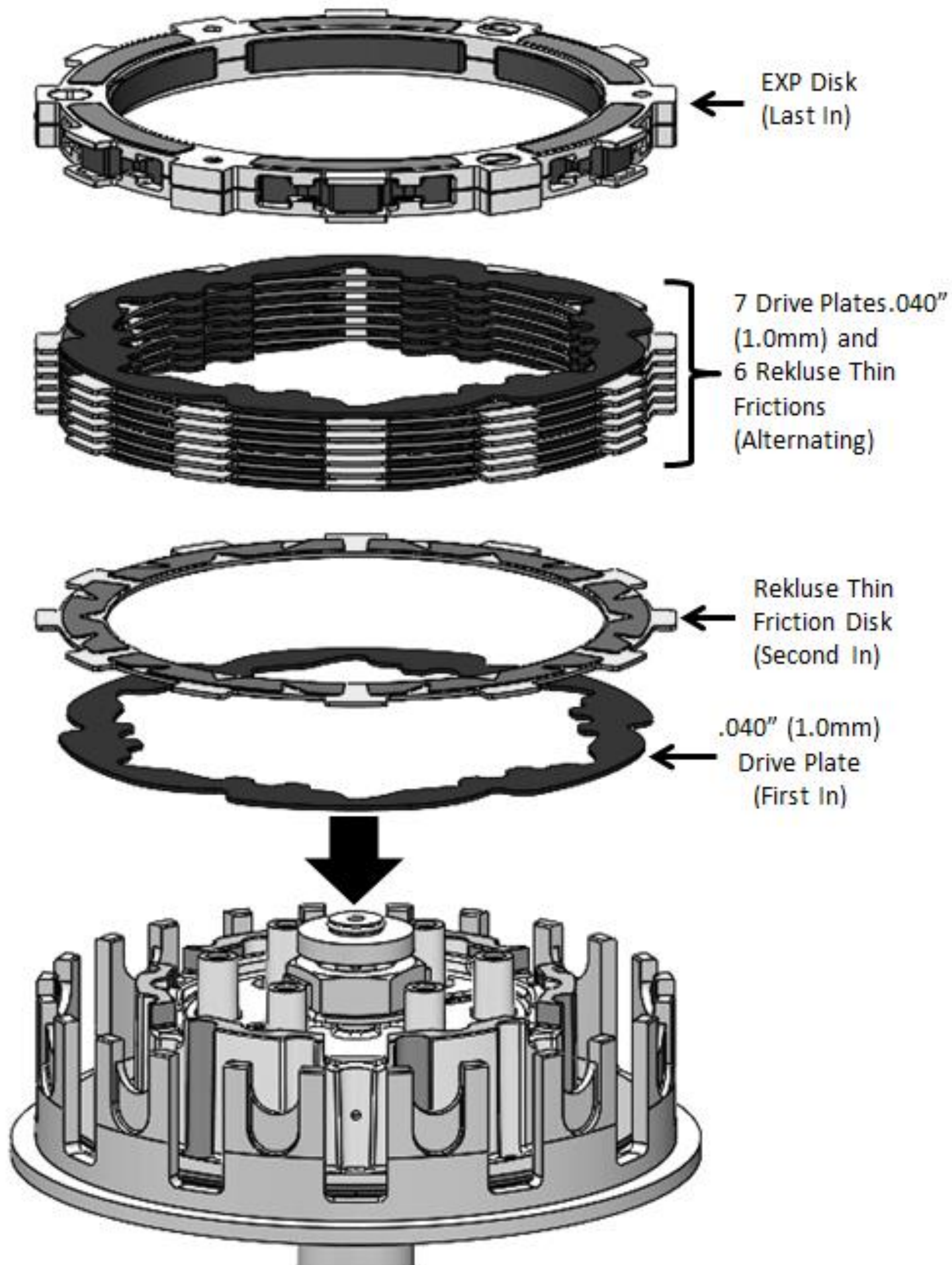

7. Place the Steel Lining Plate onto the Rekluse Pressure Plate. Adding an oil film between them will help them stick together for ease of installation.

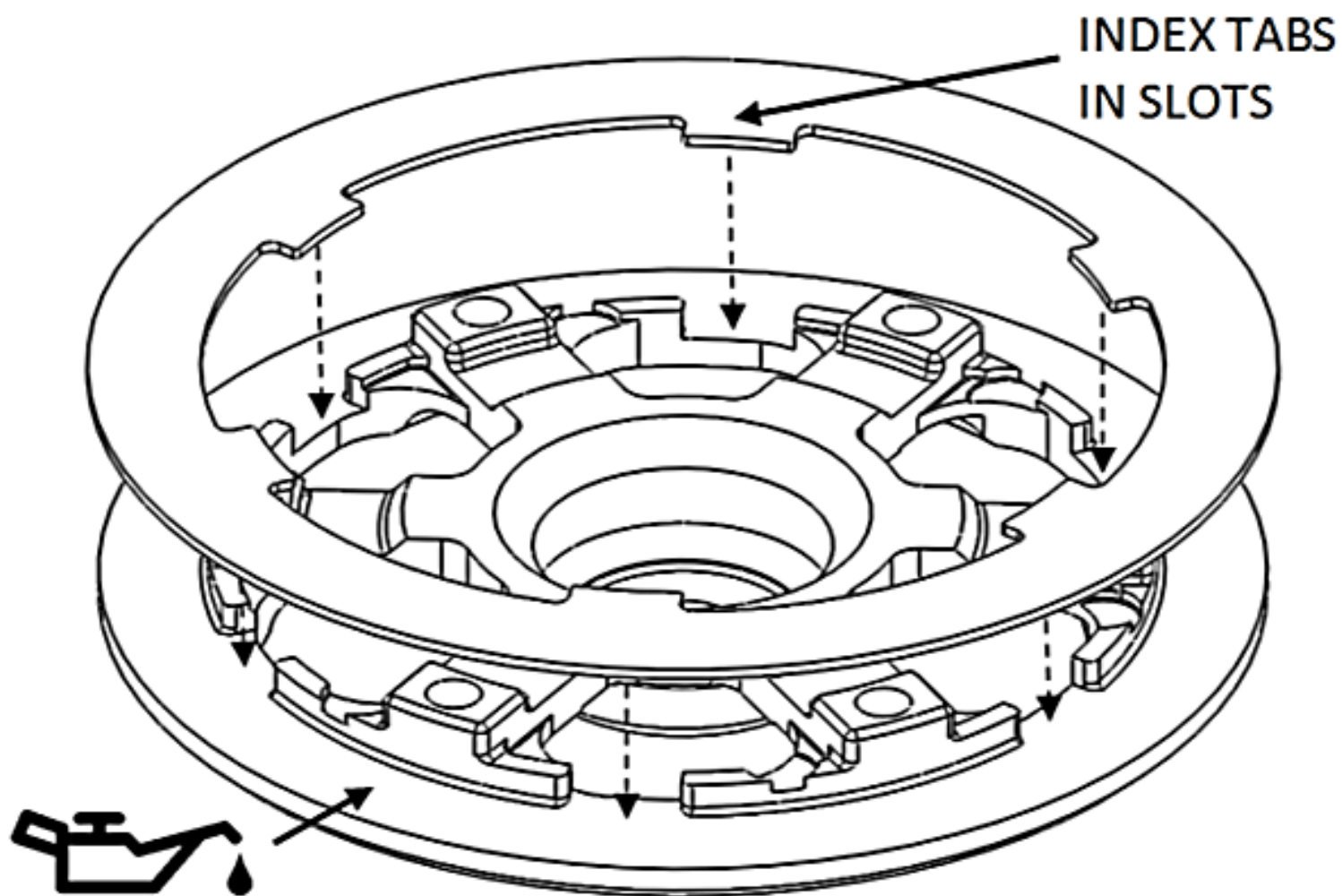

8. Install this pressure plate / lining plate combo, keeping the lining plate against the pressure plate. Hold the pressure plate against the clutch pack until it is bolted down in the later steps

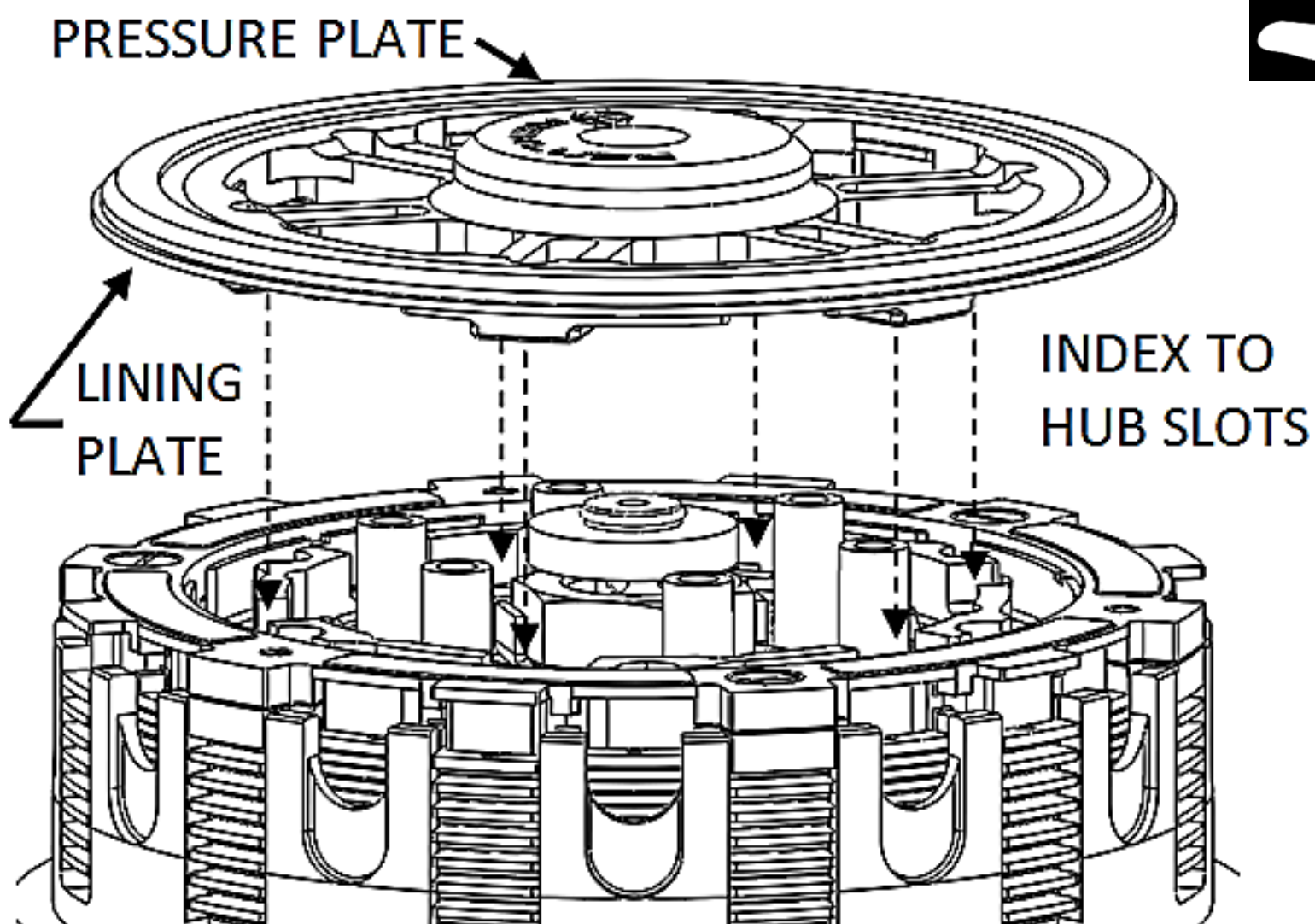

9. Install the Pressure Ring Spacer onto the hub posts.

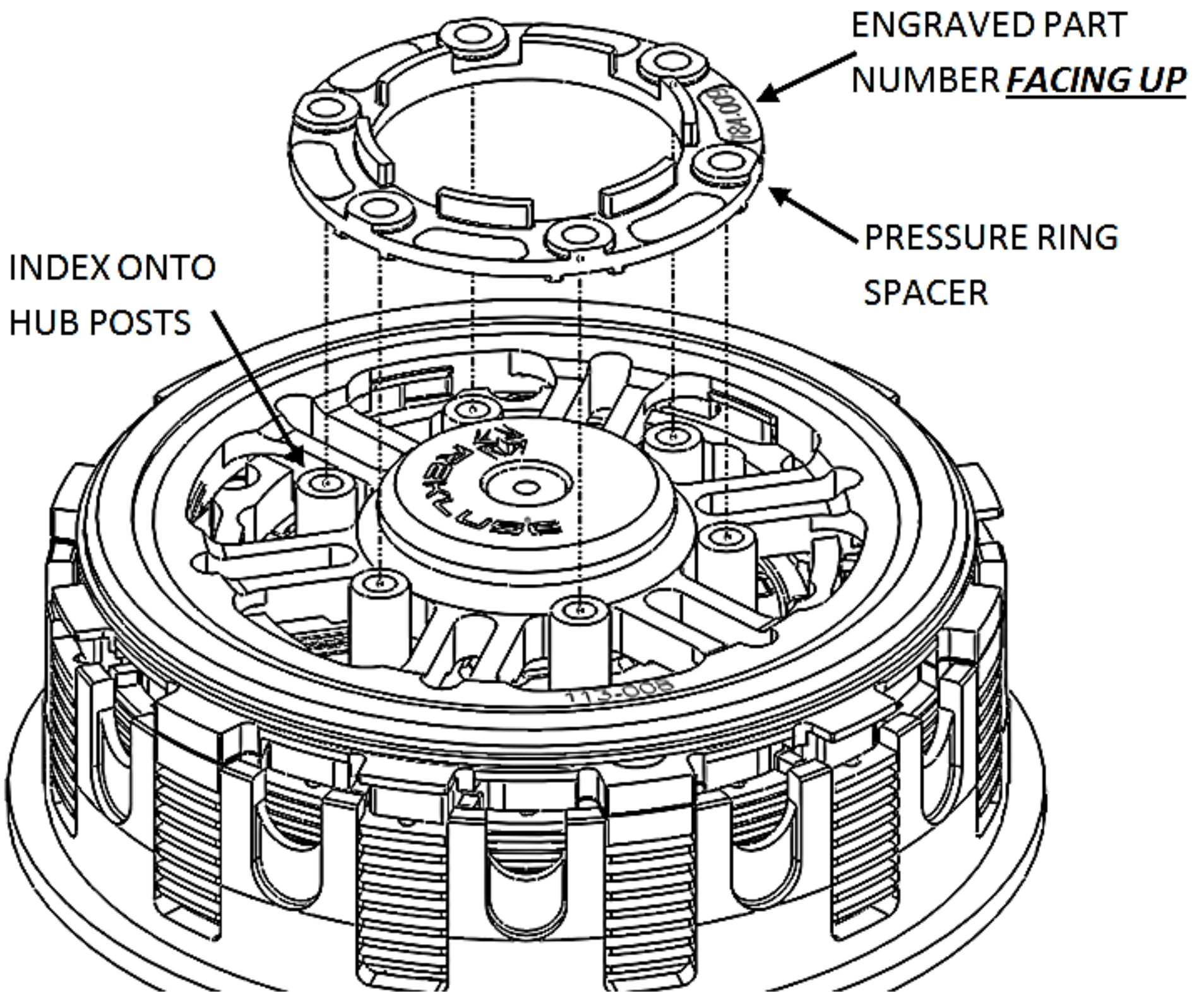

10. Install the OEM slider ring and Belleville spring.

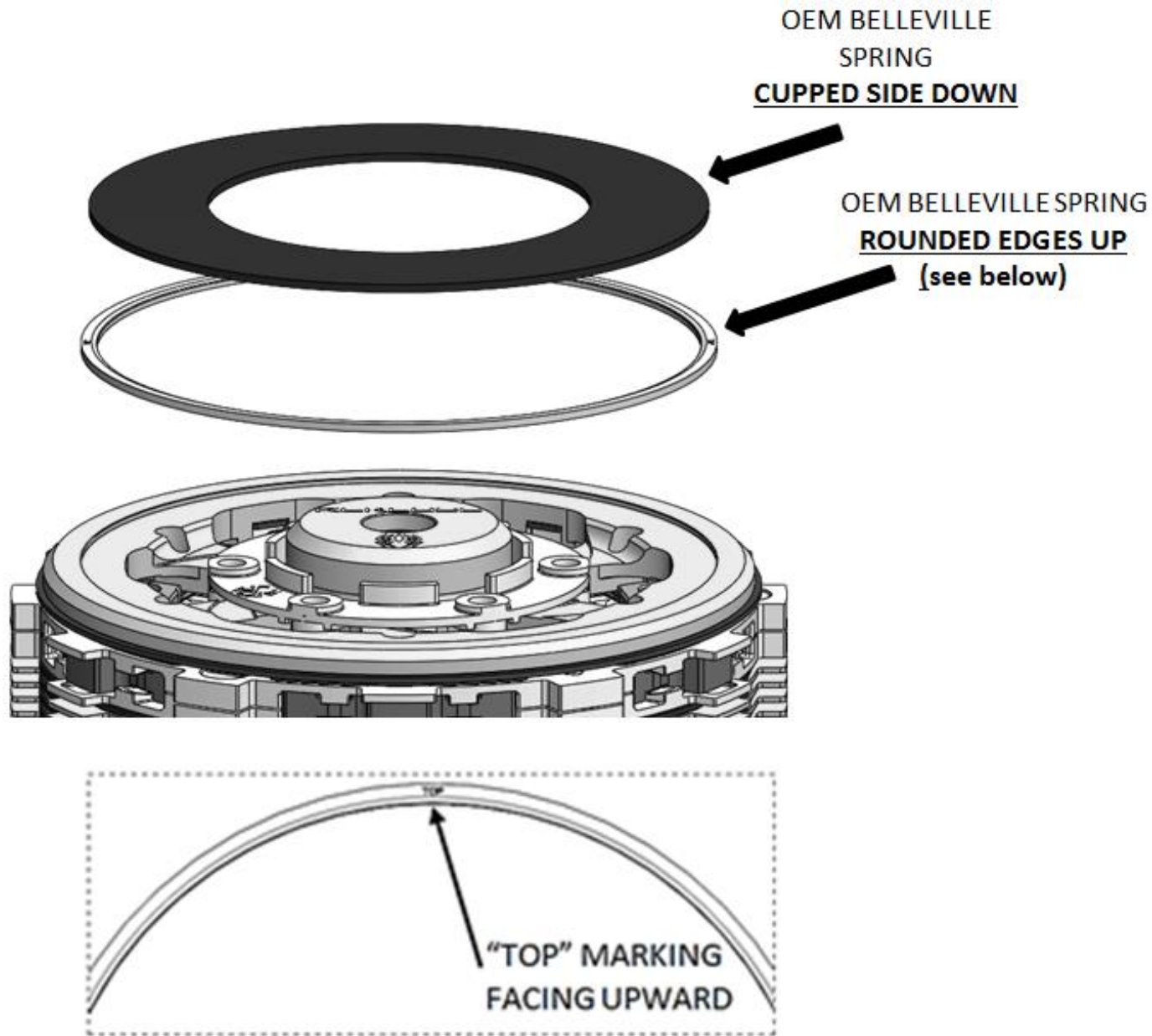

11. Install the OEM pressure ring followed by the Rekluse Pressure Plate Screws.

Do not reuse the OEM screws, or clutch cover interference will occur!

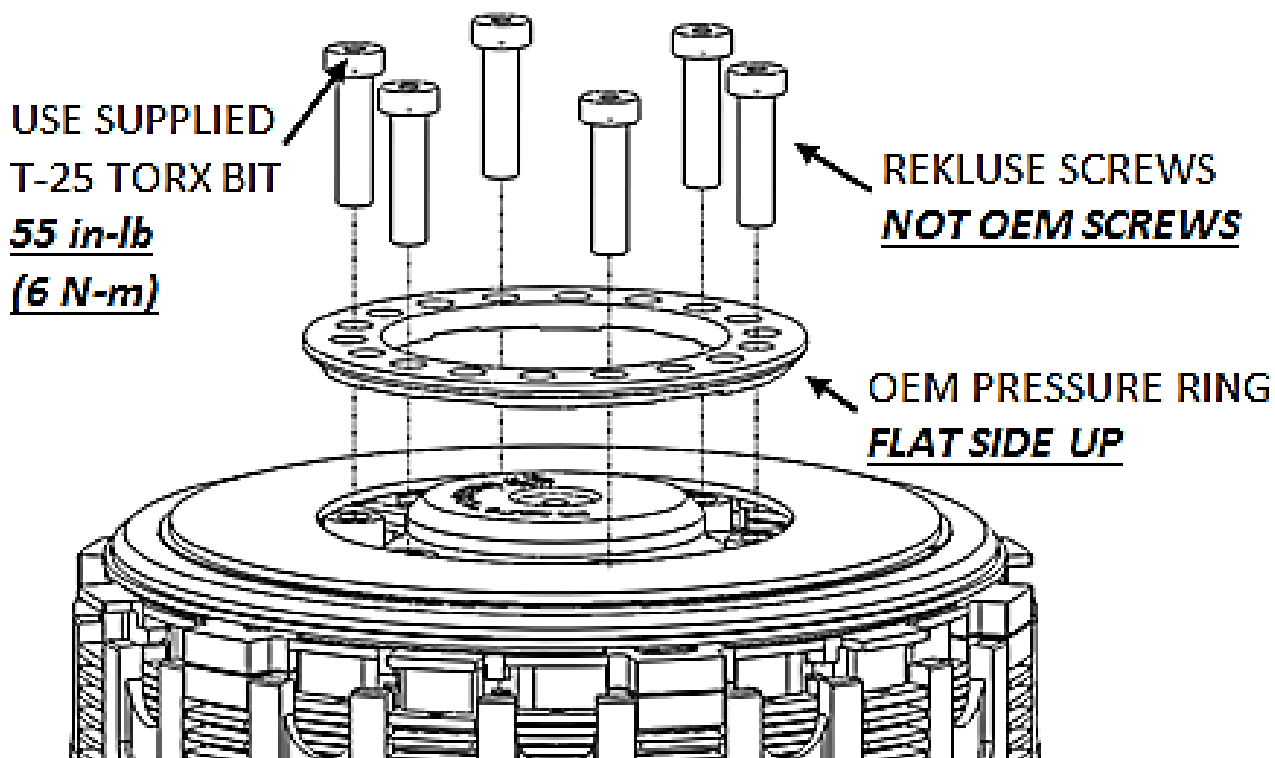

T25

NOTICE

There are 3 possible settings on the OEM Pressure Ring. Rekluse recommends setting II for all 4-strokes and III for all 2-strokes for optimum performance.

12. Install the clutch cover with Rekluse supplied Clutch Cover Gasket. Apply a thin film of engine oil to both sides of the gasket in order to prevent the gasket from sticking to the case. Install the clutch cover bolts in their proper OEM location and Torque the cover bolts to OEM specification – 7.4 ft-lb (10 N-m).



8 mm

⚠ WARNING

If the Rekluse supplied gasket is not used, damage will occur to the clutch! Failure to install the OEM clutch cover bolts back in their proper location can result in damage to your motorcycle.

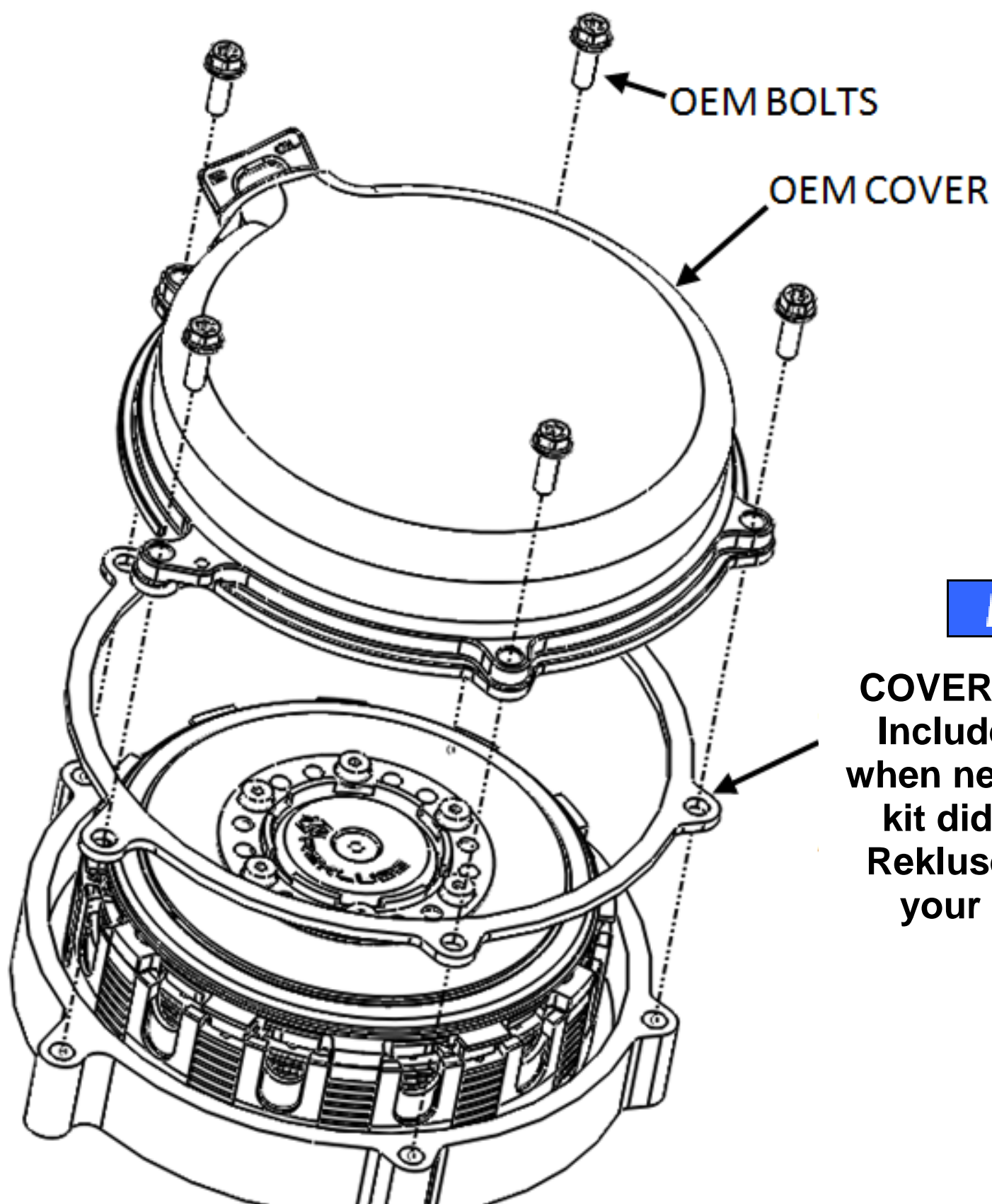

NOTICE

**COVER GASKET [#55]
Included only in kits
when necessary. If your
kit did not include a
Rekluse gasket reuse
your OEM gasket.**

SLAVE CYLINDER INSTALLATION

Handle with care! During assembly there is a small ball bearing installed in the slave piston with a small amount of grease. When installing the Rekluse slave cylinder, make sure the ball does not come loose.



13. Stand the bike up and lean it on its kickstand or place it on a suitable bike stand.



14. Starting at the slave cylinder, remove the OEM parts named in the following diagram beginning with the banjo bolt.

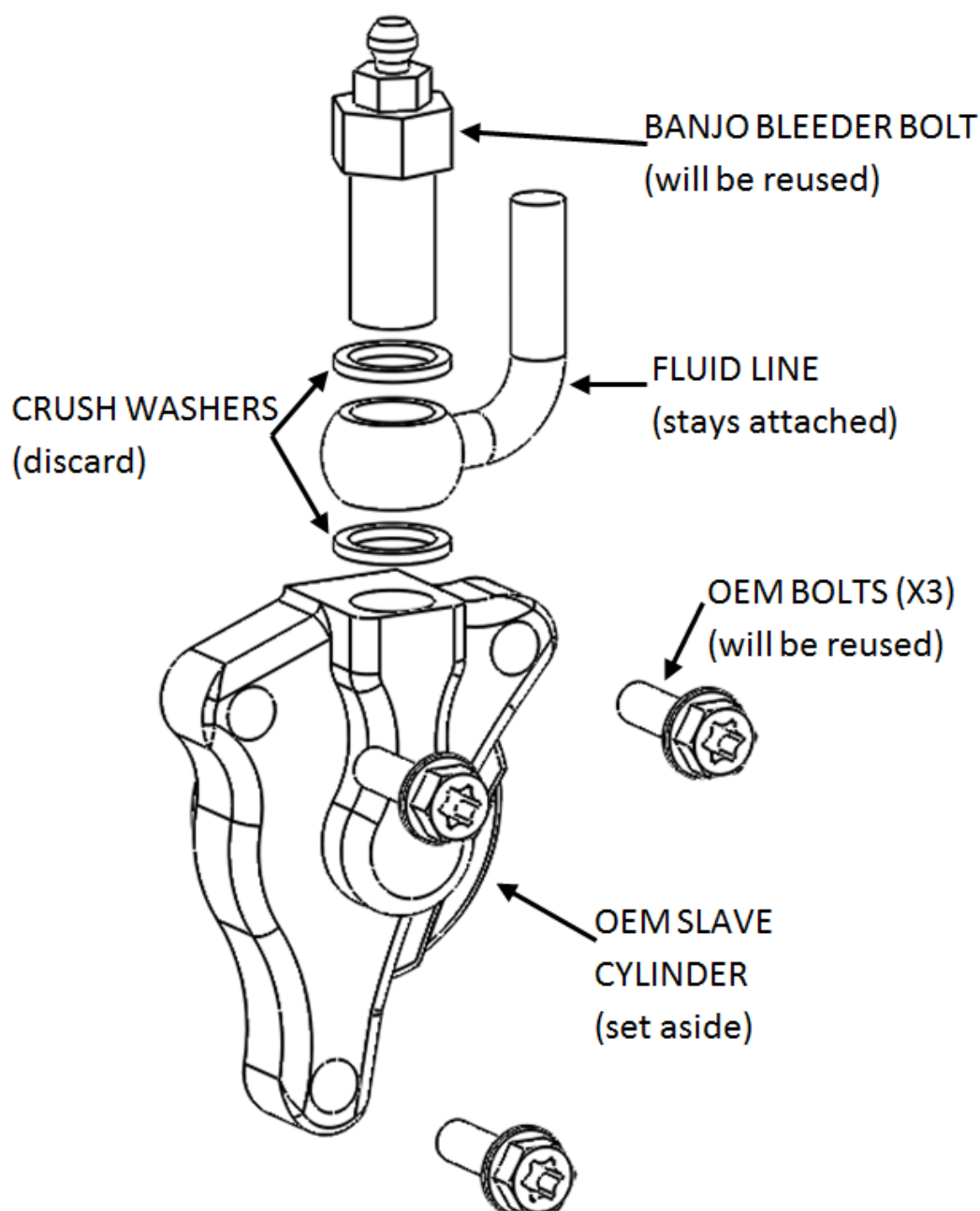

8 mm



15. On a workbench (still away from the engine), bleed the Rekluse slave cylinder by this procedure:

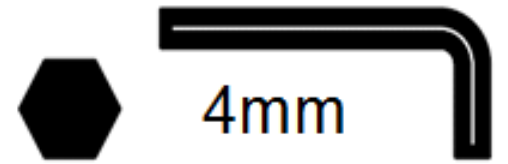

a. Use a 4mm Allen key to make the top O-Ring visible on the adjuster screw.

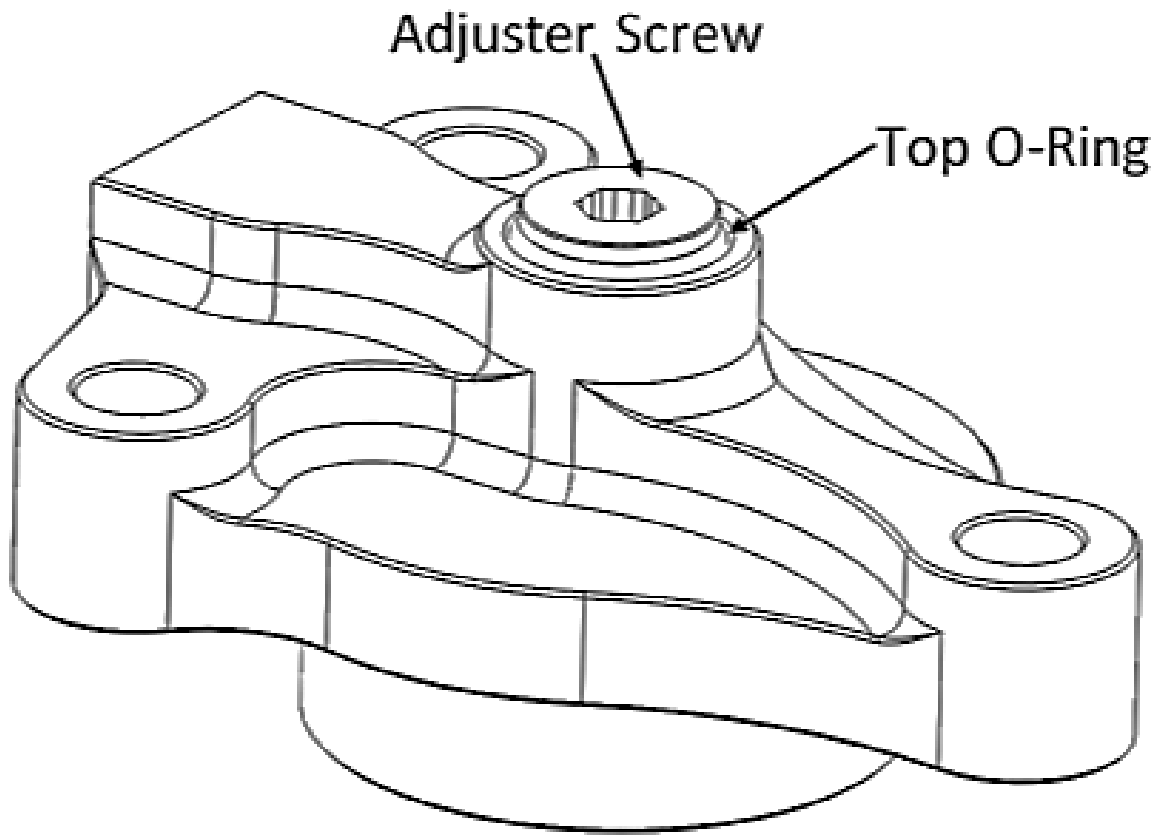

b. Compress the piston until it bottoms.

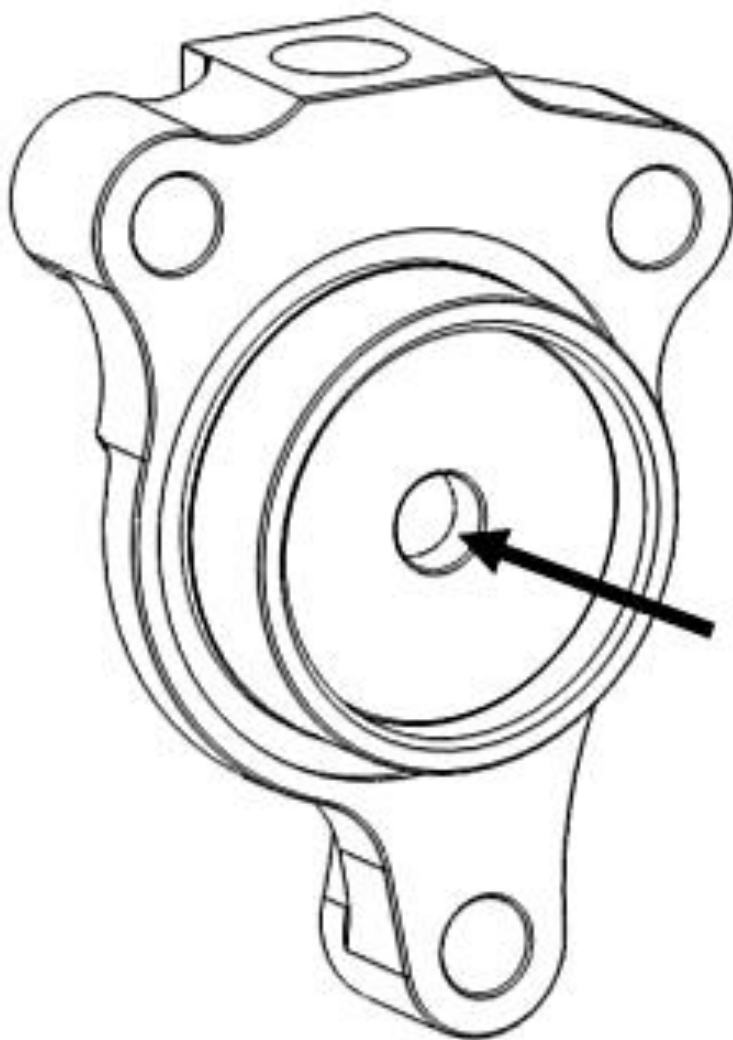

c. Pour clutch fluid into the slave cylinder port.

NOTICE

Be sure to use the correct clutch fluid! Check the cap of the clutch master cylinder to determine which clutch fluid to use. Failure to use the correct fluid will result in seal damage and/or failure.

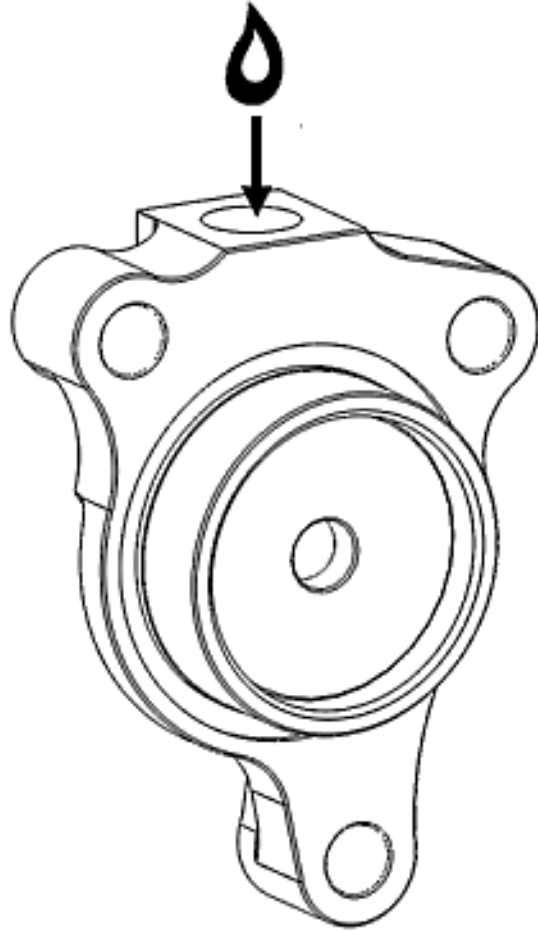
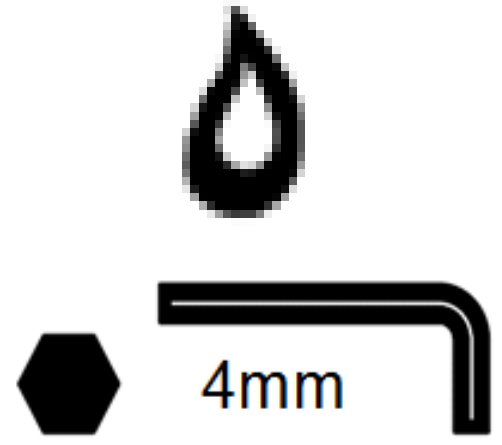

d. Turn the adjuster screw clockwise until it bottoms, keeping the fluid topped off.

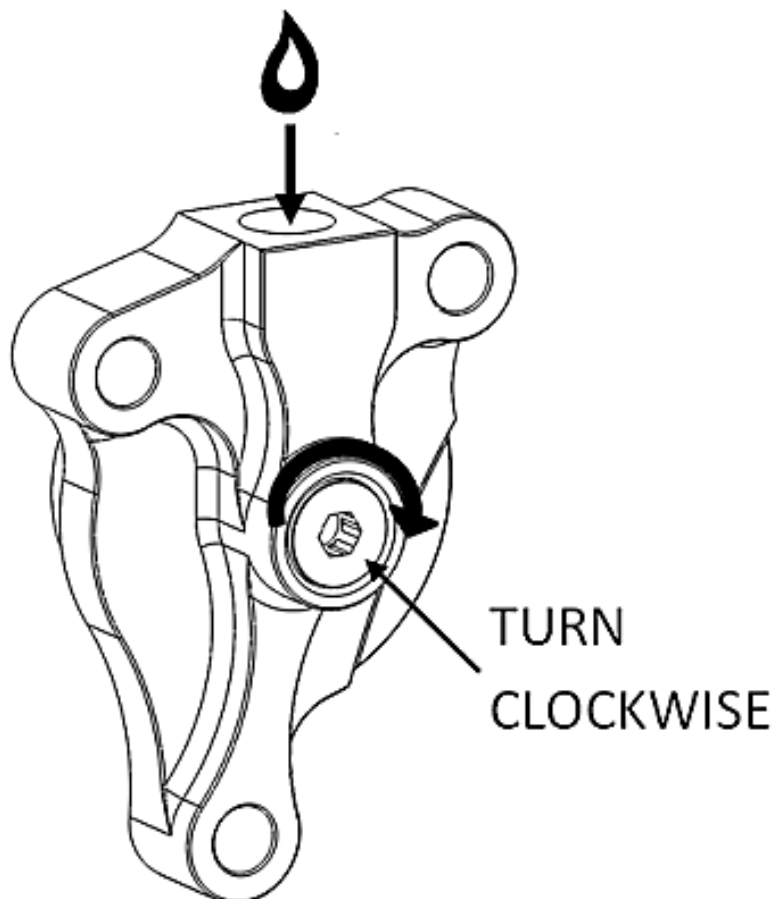

e. Turn the adjuster screw back to the initial position with the top O-ring visible.

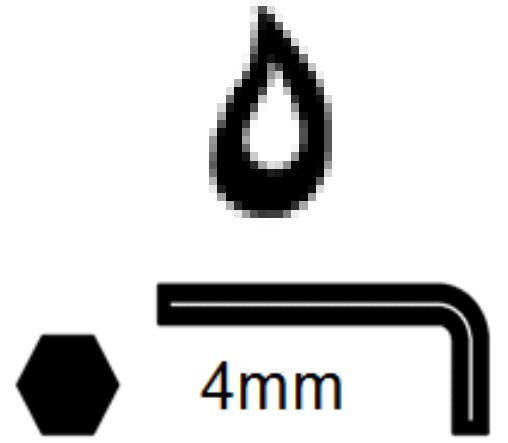
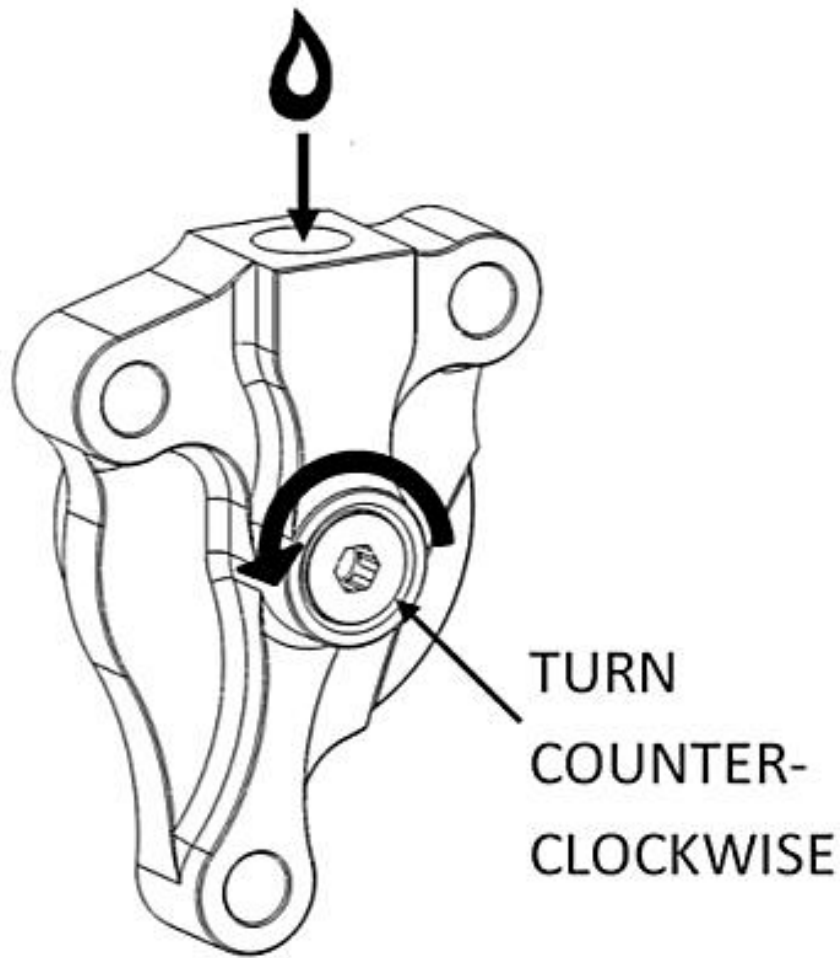

f. Compress the piston until it bottoms out. Repeat the process until there is no longer air escaping from the top port when the piston is compressed.

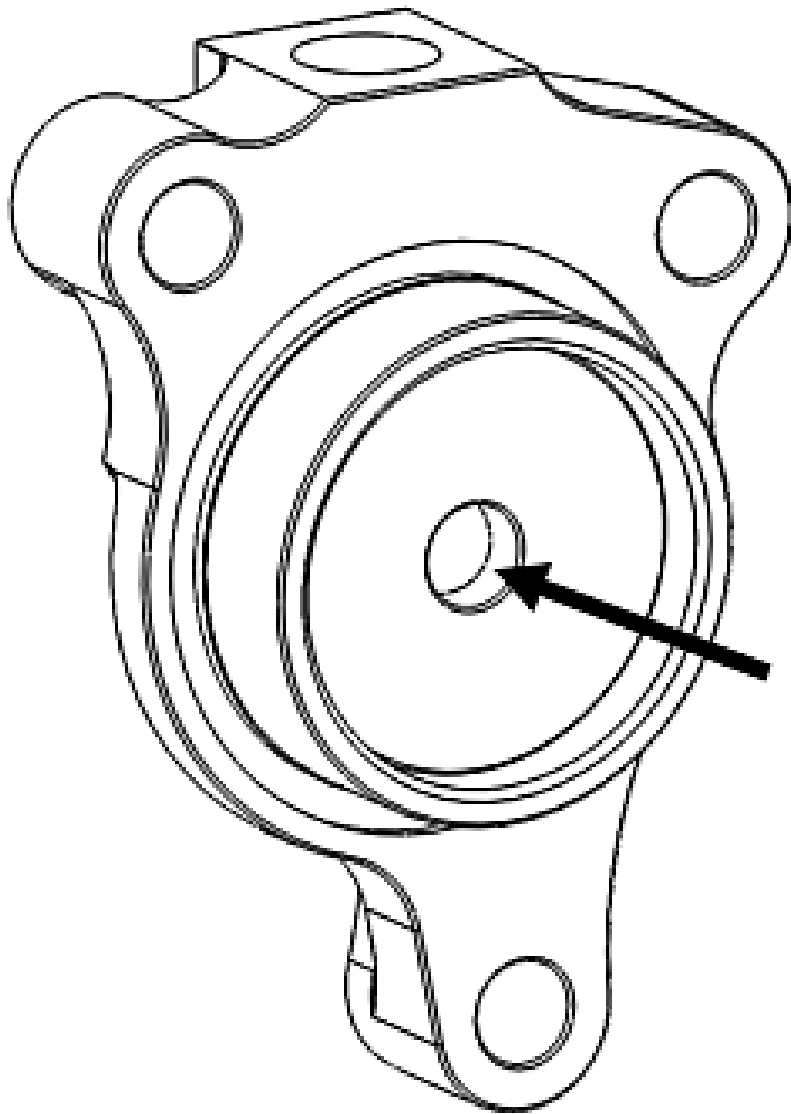

NOTICE

When compressing the piston, fluid can shoot out from the slave cylinder port. Be sure to wear eye protection.

16. Check that the ball bearing is still in place.

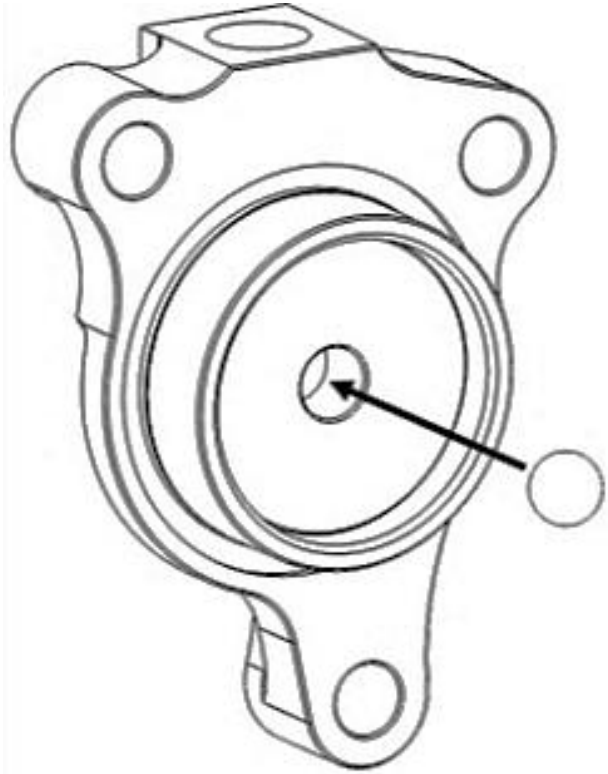

17. Install the Rekluse slave cylinder on the bike using these parts, ending with the banjo bolt.

NOTICE

For Husqvarna 450/501 models, use Rekluse supplied Banjo Bolt included in kit.



8 mm

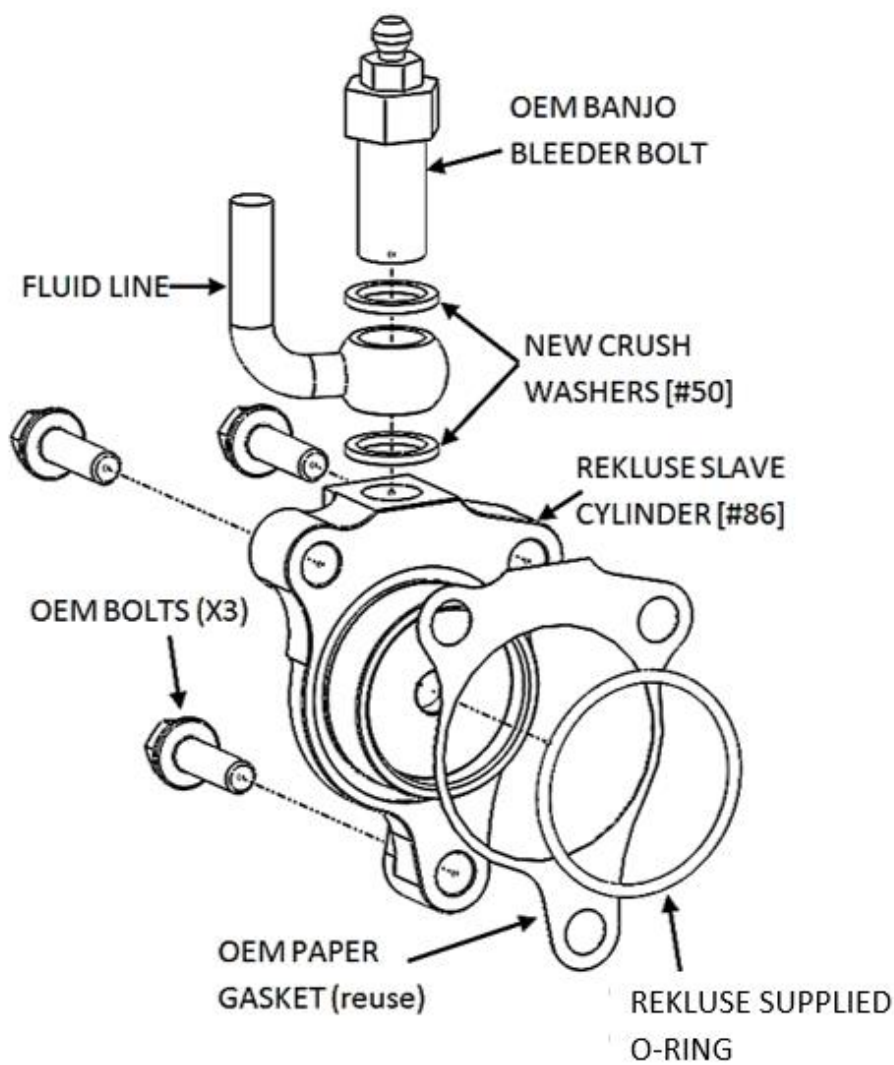

NOTICE

Some models have a paper gasket. Reuse them if OEM equipped. Install the Rekluse supplied O-Ring onto the slave cylinder housing as shown.

NOTICE

When installing case sealing O-ring seal (OEM or Rekluse supplied) ensure it is seated against slave cylinder flange.

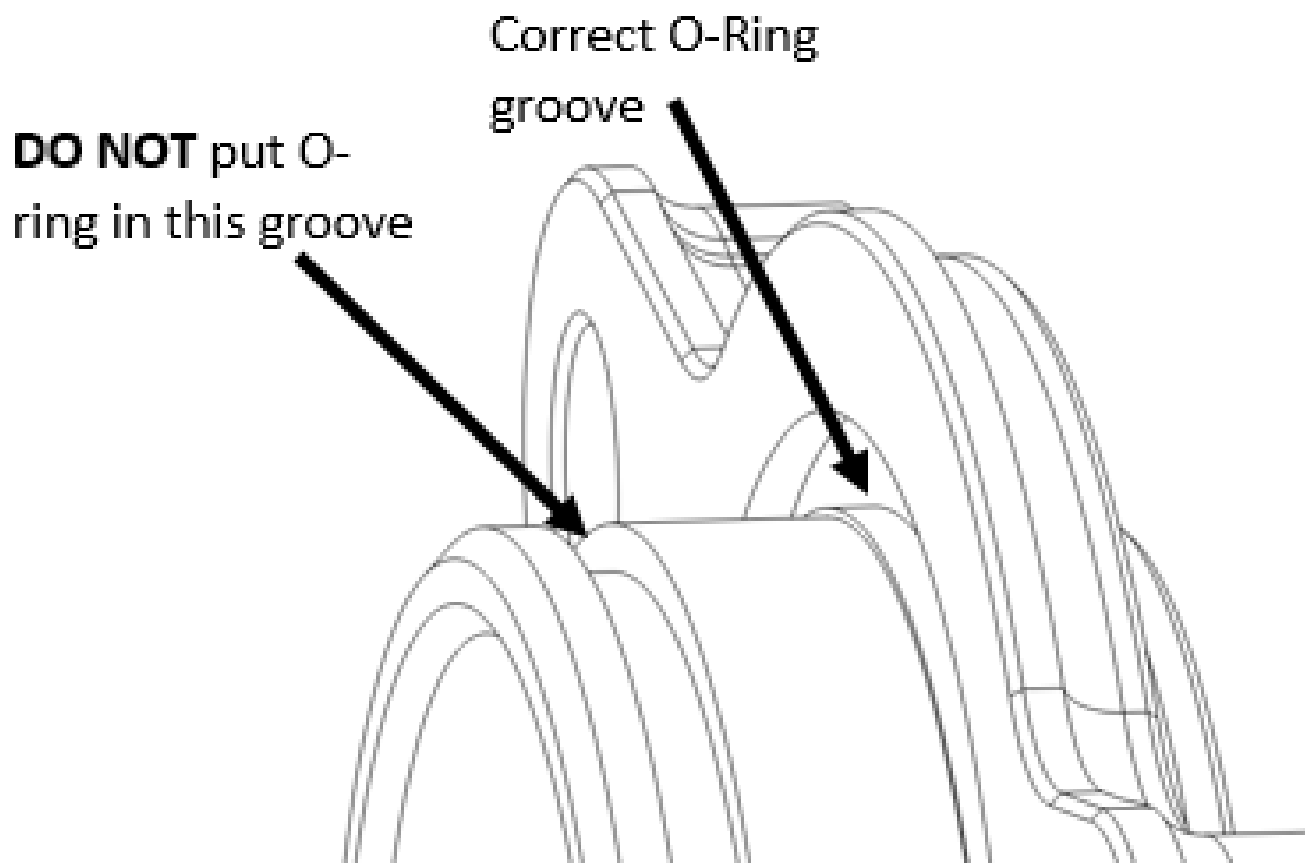

NOTICE

Some models have a piston diaphragm seal. **DO NOT REUSE** them if OEM equipped.

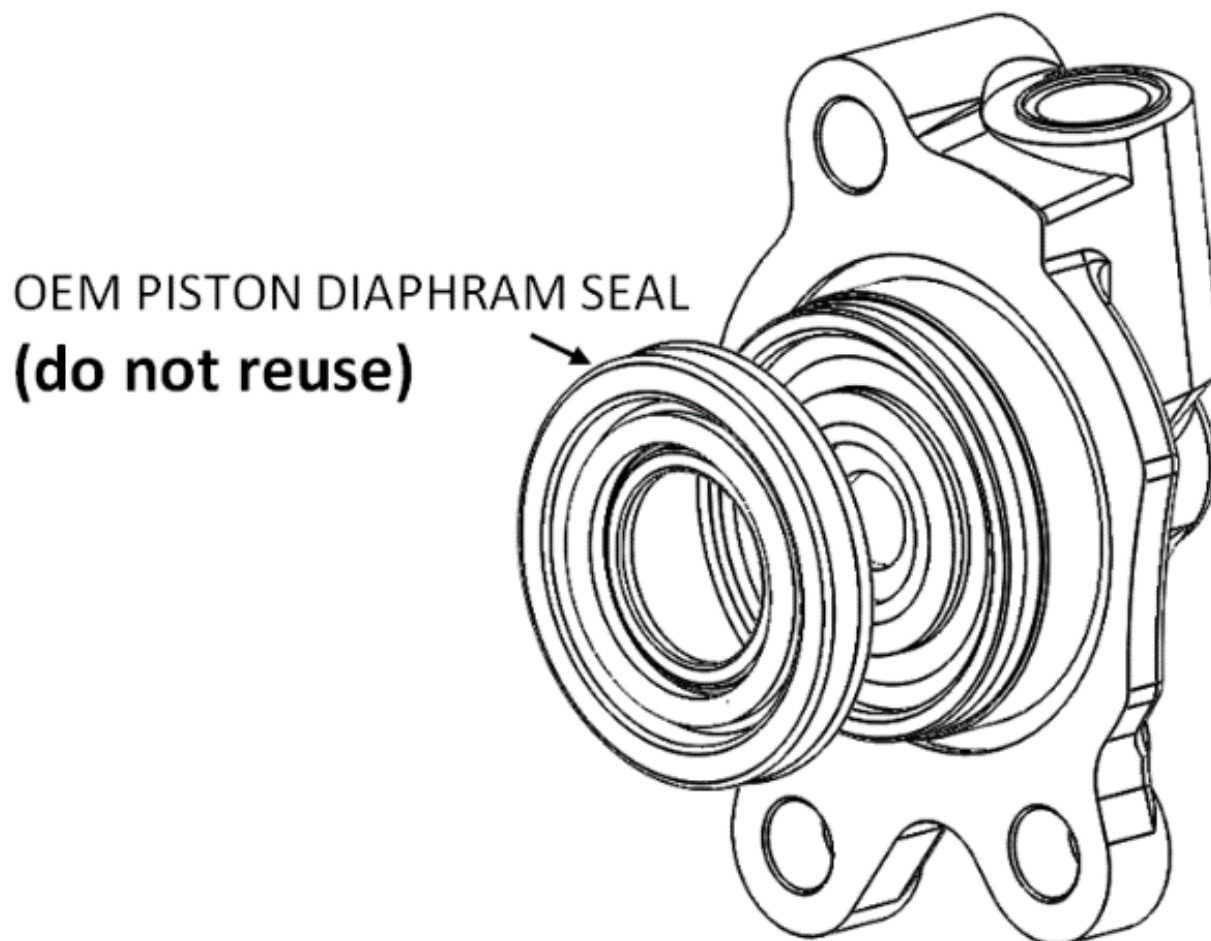

NOTICE

If you are installing on a Freeride bike model, see the **Slave Cylinder Appendix** sheet for proper fitment instructions.

18. Optional: If you purchased the Rekluse Slave Guard accessory, install it now using the instructions in the kit.

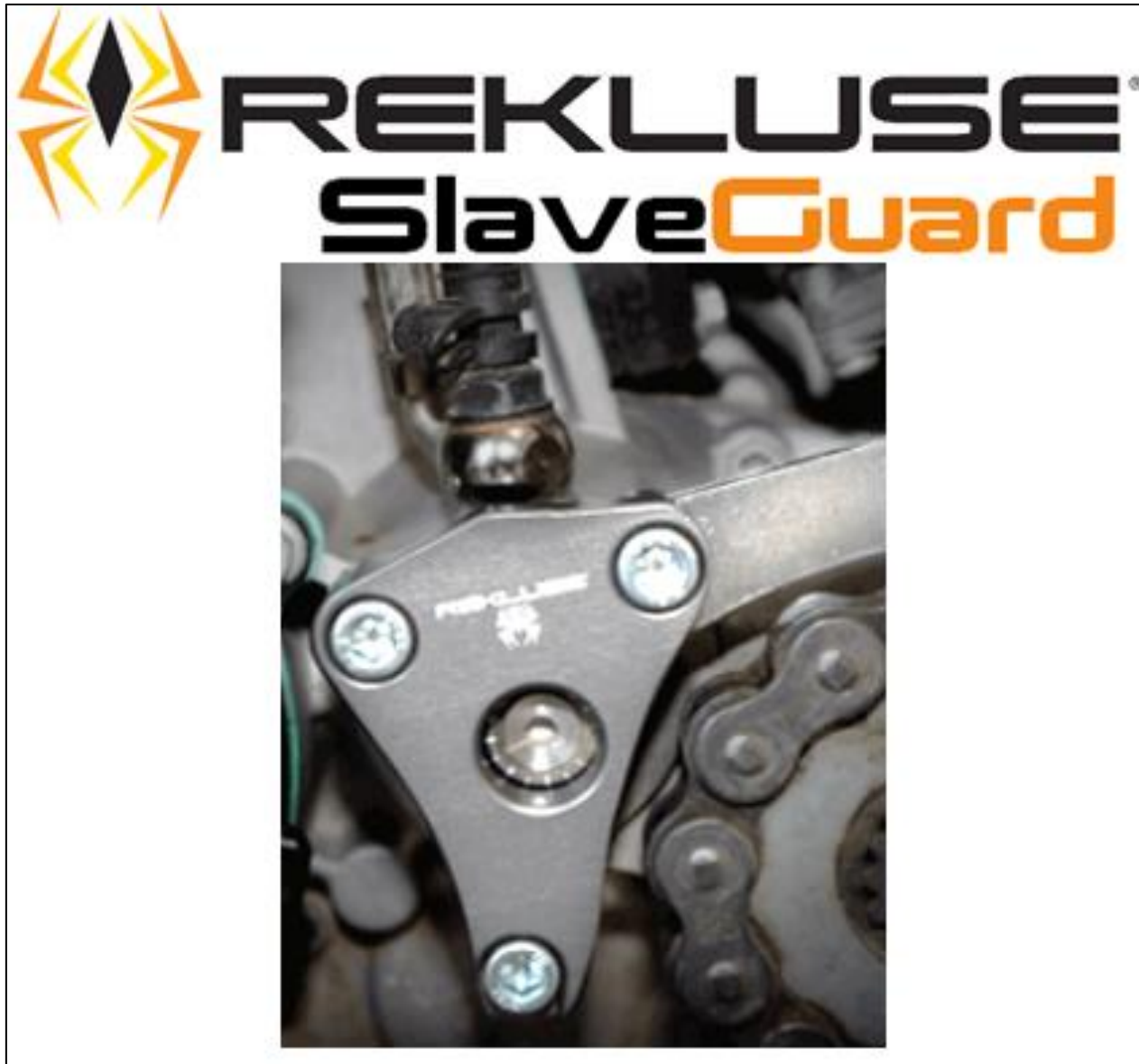

19. Remove the cap and bladder from the clutch master cylinder and top off the clutch fluid.

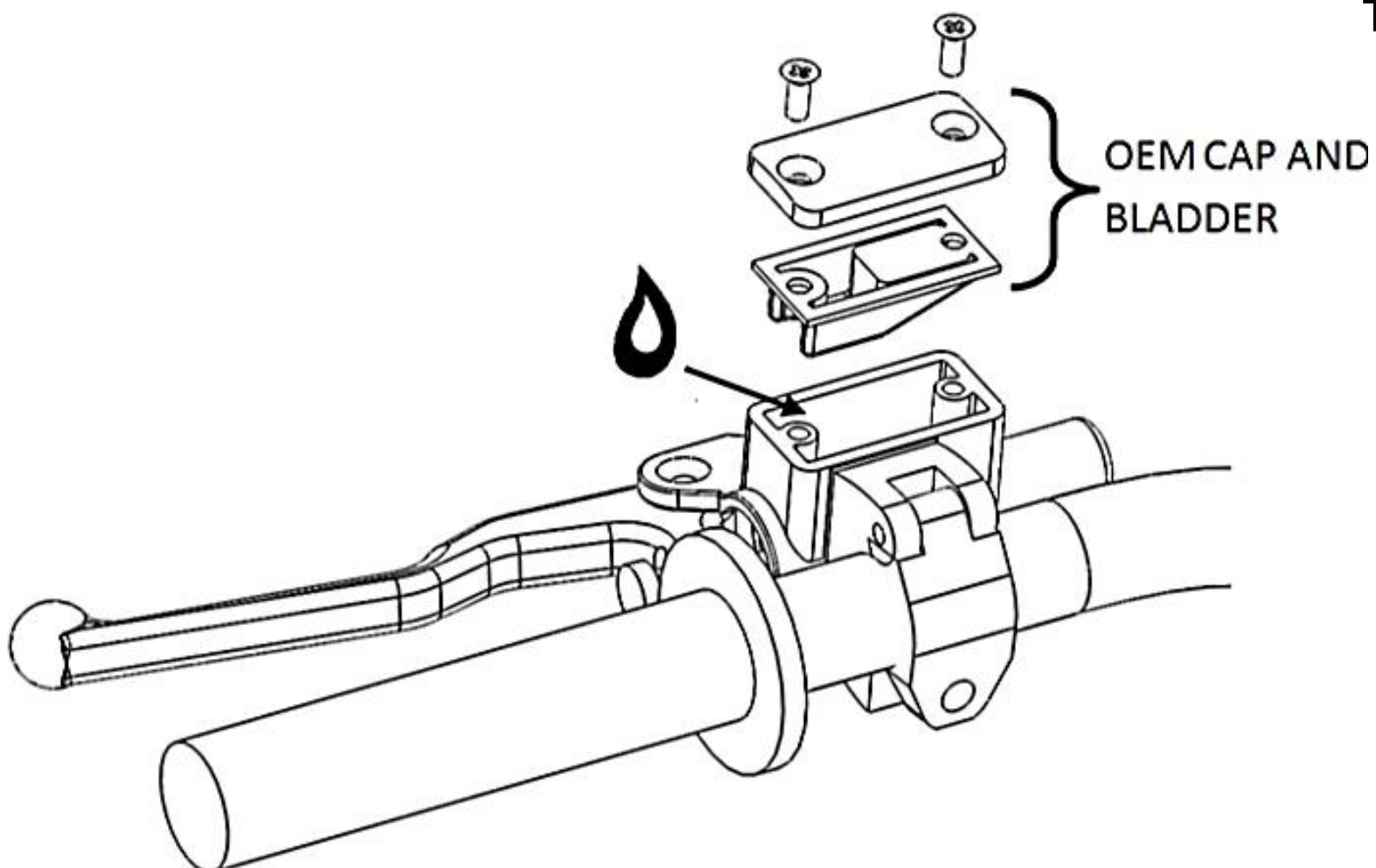

20. Attach the supplied bleed tube to the banjo bolt port and loop it into a suitable catch bottle.

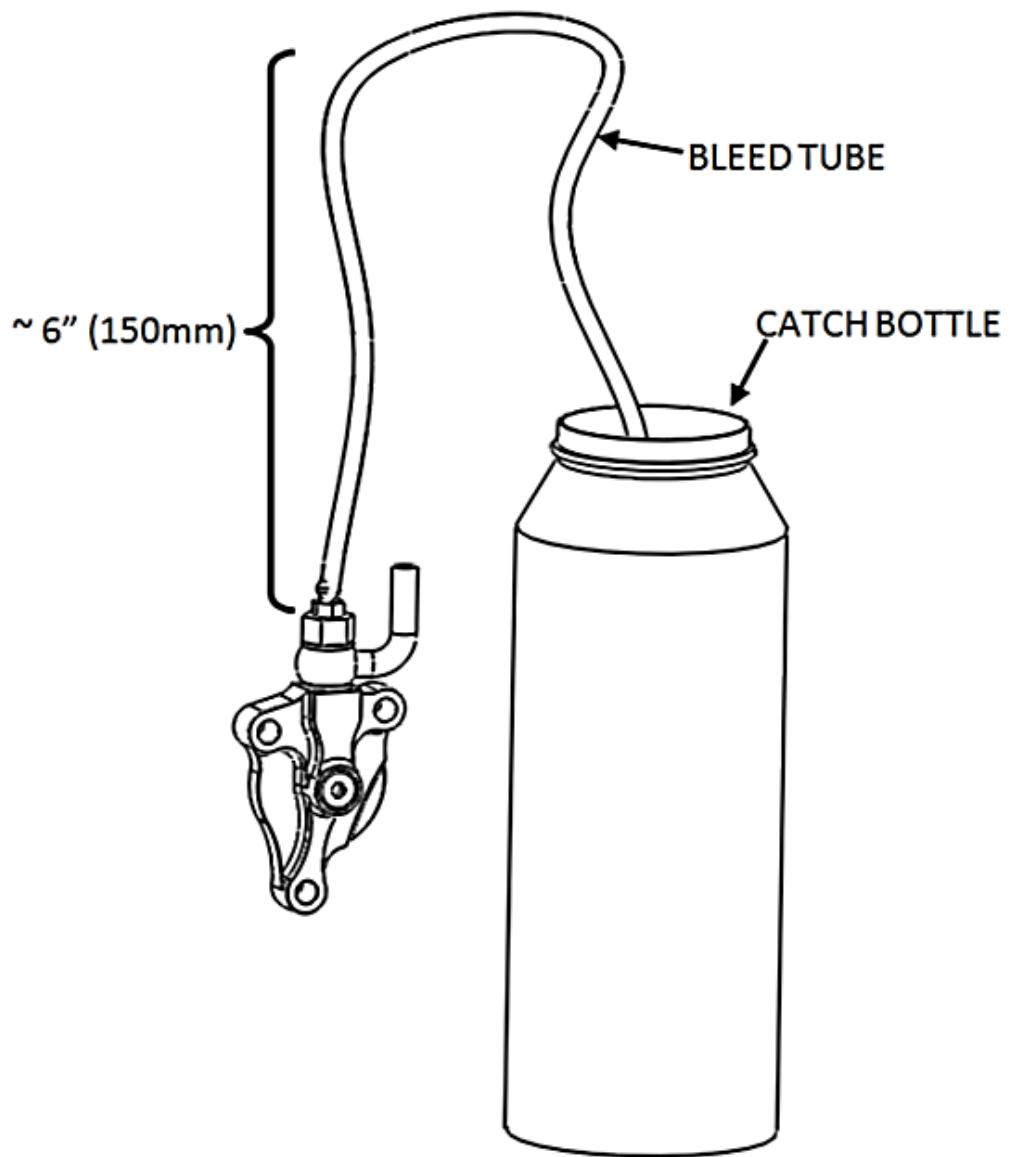

21. Pump the clutch lever 3-5 times then hold it against the bar/grip.

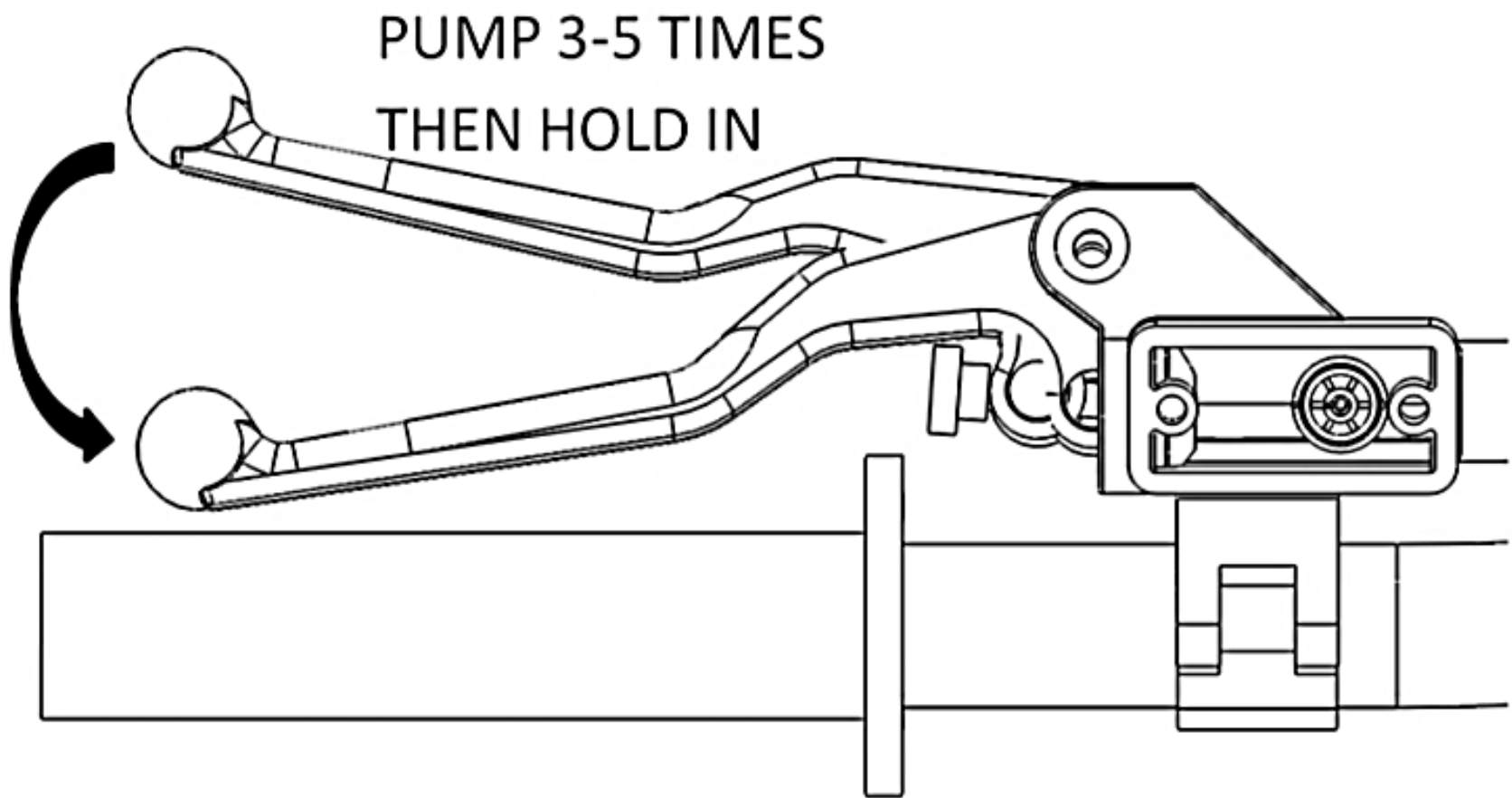

22. Using an 8mm wrench, open the bleed port. Air and fluid should come out of the bleed tube. Tighten the bleed port.

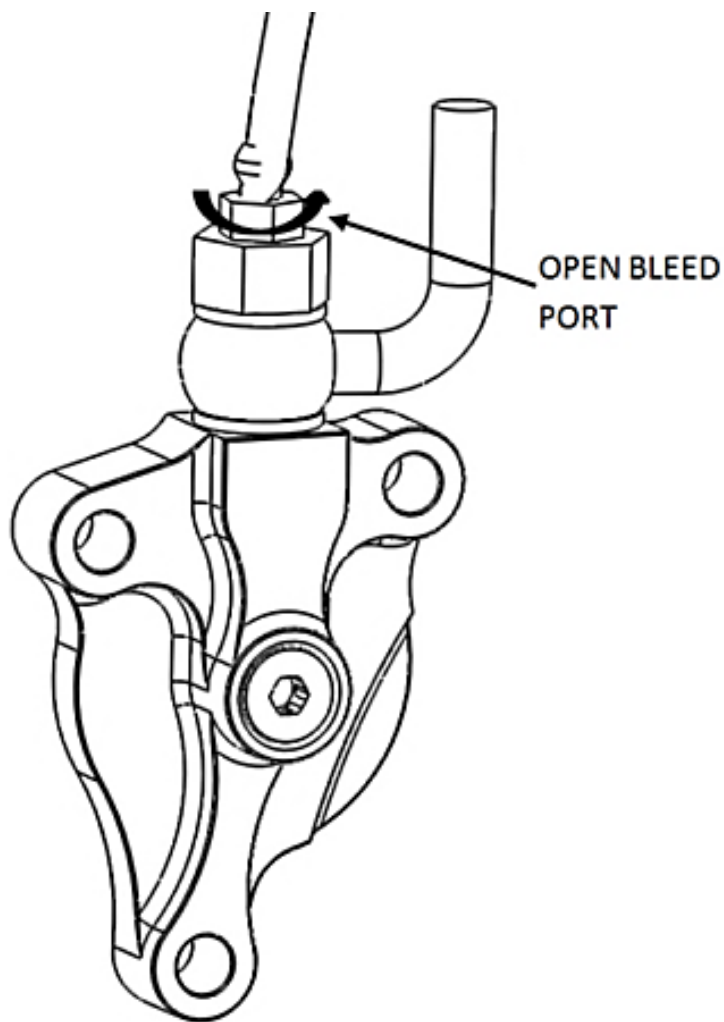

23. Slowly release the clutch lever and check the fluid level in the clutch master cylinder.

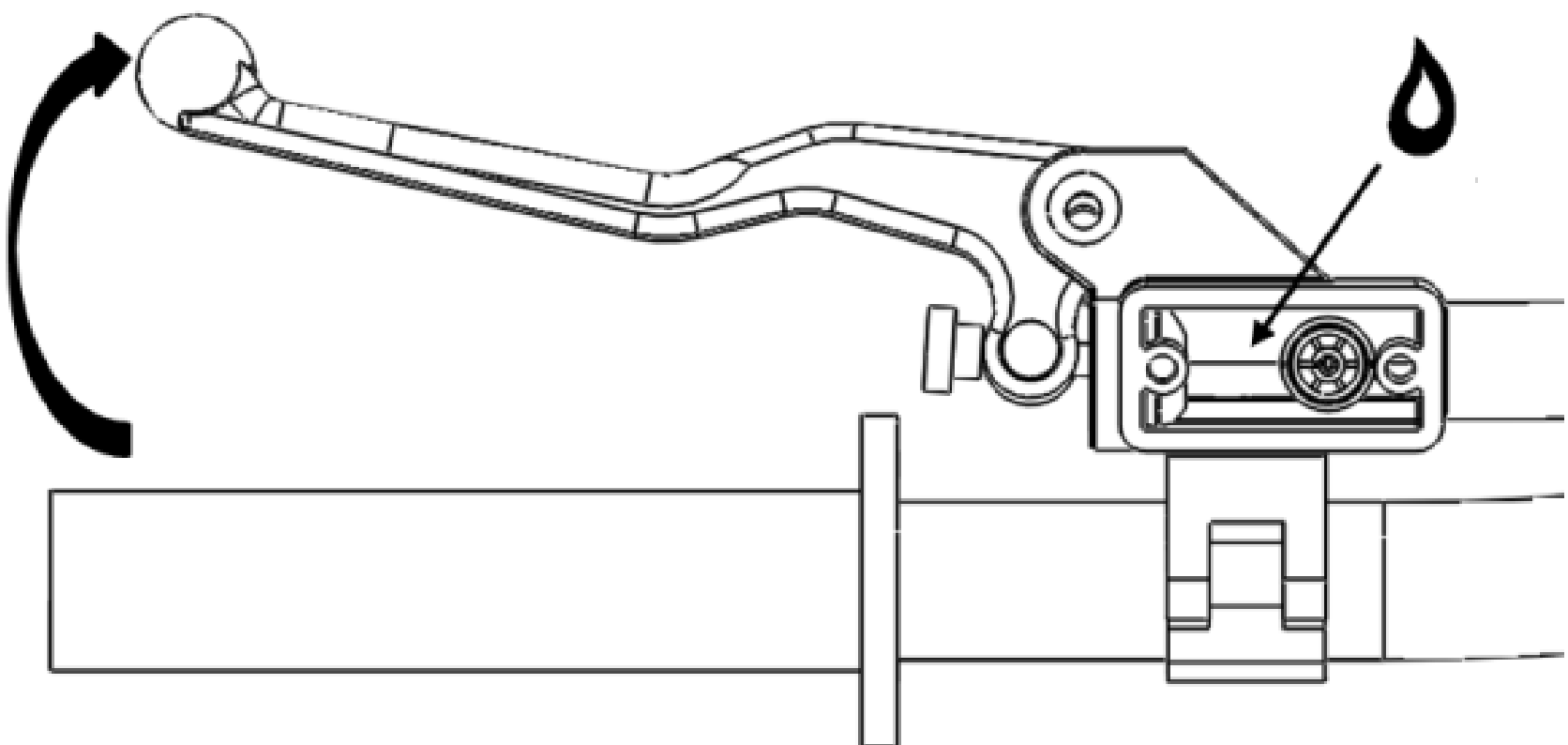
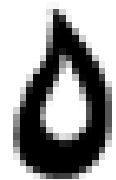

24. Repeat the previous 3 bleeding steps until air no longer comes out of the bleed port. Then, check that the clutch lever functions properly. Repeat the bleeding procedure if necessary.

25. Finally, remove the bleed tube and tighten the bleed port.



SETTING THE INSTALLED GAP

DEFINITION: “Installed Gap” is the separation in the clutch pack created by the adjustment of the Adjuster Screw in the Slave Cylinder. This gap is what allows the clutch to spin freely until the desired RPM is reached for engagement; it must be set correctly for optimal performance.

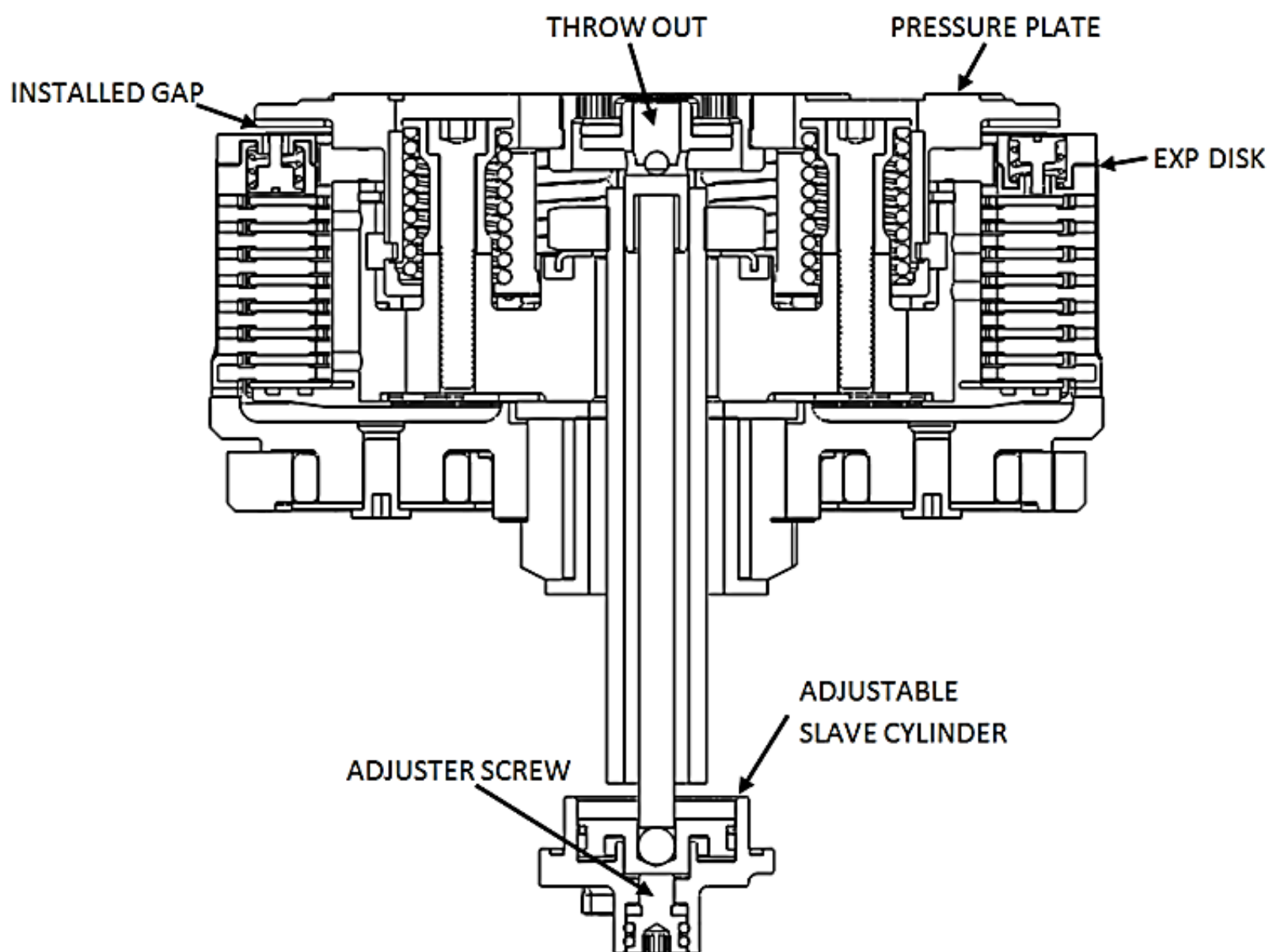

26. Using the long end of a 4mm Allen key, turn the adjuster screw clockwise until it stops under moderate pressure. You are trying to feel for the point at which the throwout will start to lift the pressure plate. This is the “starting point”.

NOTICE

It may take a few tries to find the point at which the system is bottomed out. You should feel a distinguishable change in turning effort at this point.

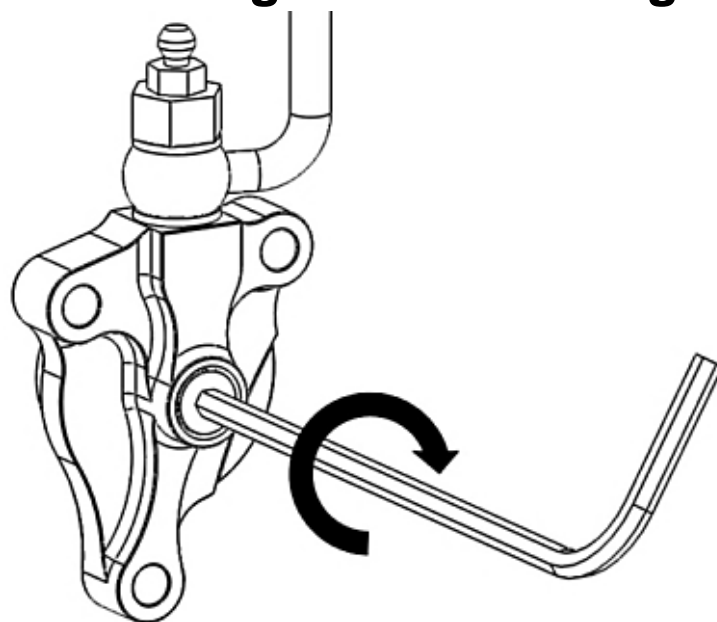

27. Once you have found the starting point, turn the adjuster clockwise 1 full turn plus 5 marks (or "1+5"). **This is NOT your final setting**, but it is a good reference point for using free play gain to find the correct setting.

28. Top off your master cylinder fluid level, and re-install the master cylinder cap.



T20

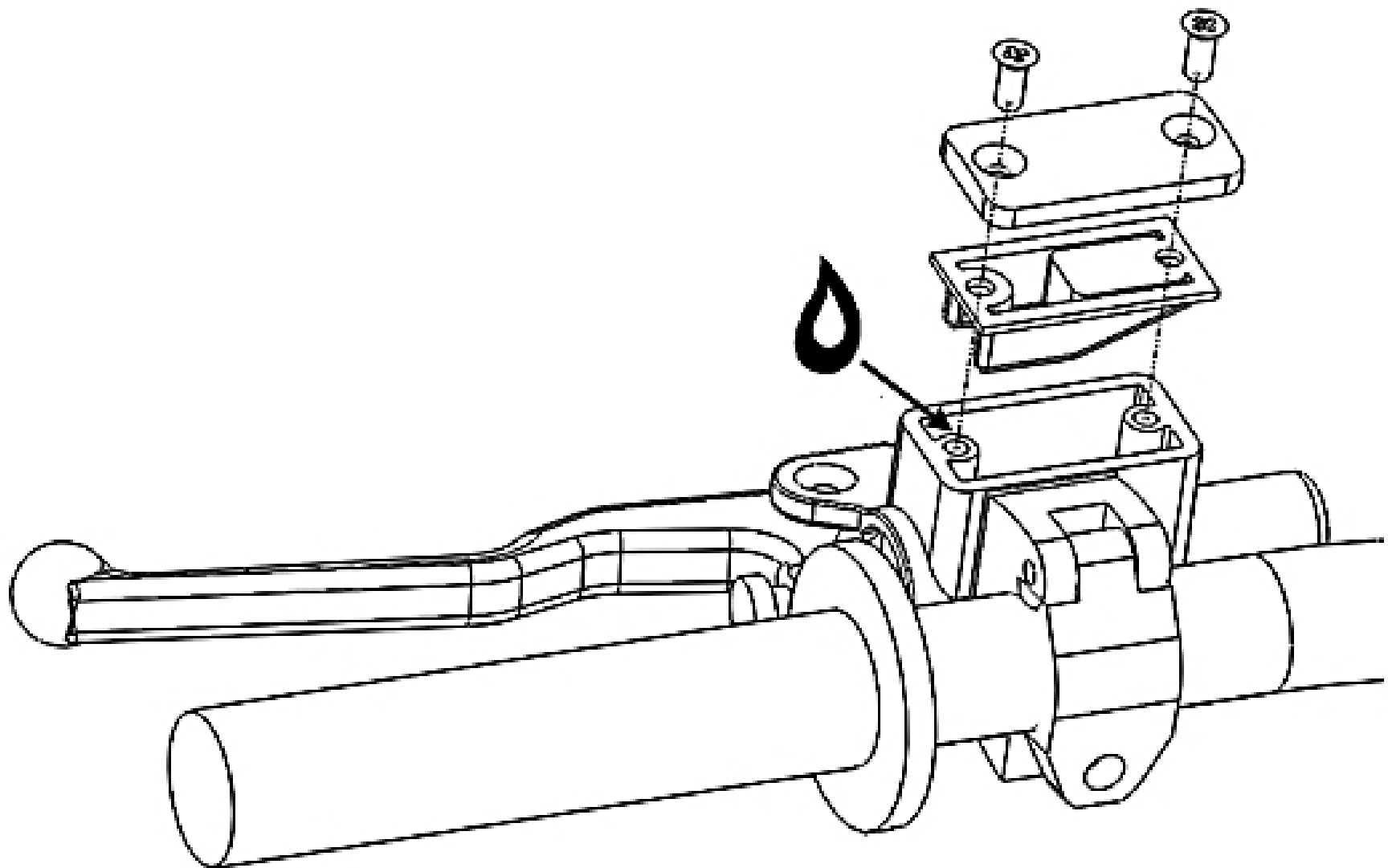

CHECKING FREE PLAY GAIN

⚠ WARNING

Always make sure that the bike is in NEUTRAL before checking Free Play Gain. Failure to do so may result in the bike lurching forward, and loss of control and/or injury may result.

NOTICE

Before performing this step, please visit our website at rekluse.com/support to view the TECH VIDEO entitled “How to Check Free Play Gain”.



“**Lever Free Play**” is essentially the “slack” in the clutch lever before it starts actuating the clutch. Applying a light finger pressure will take up this slack.

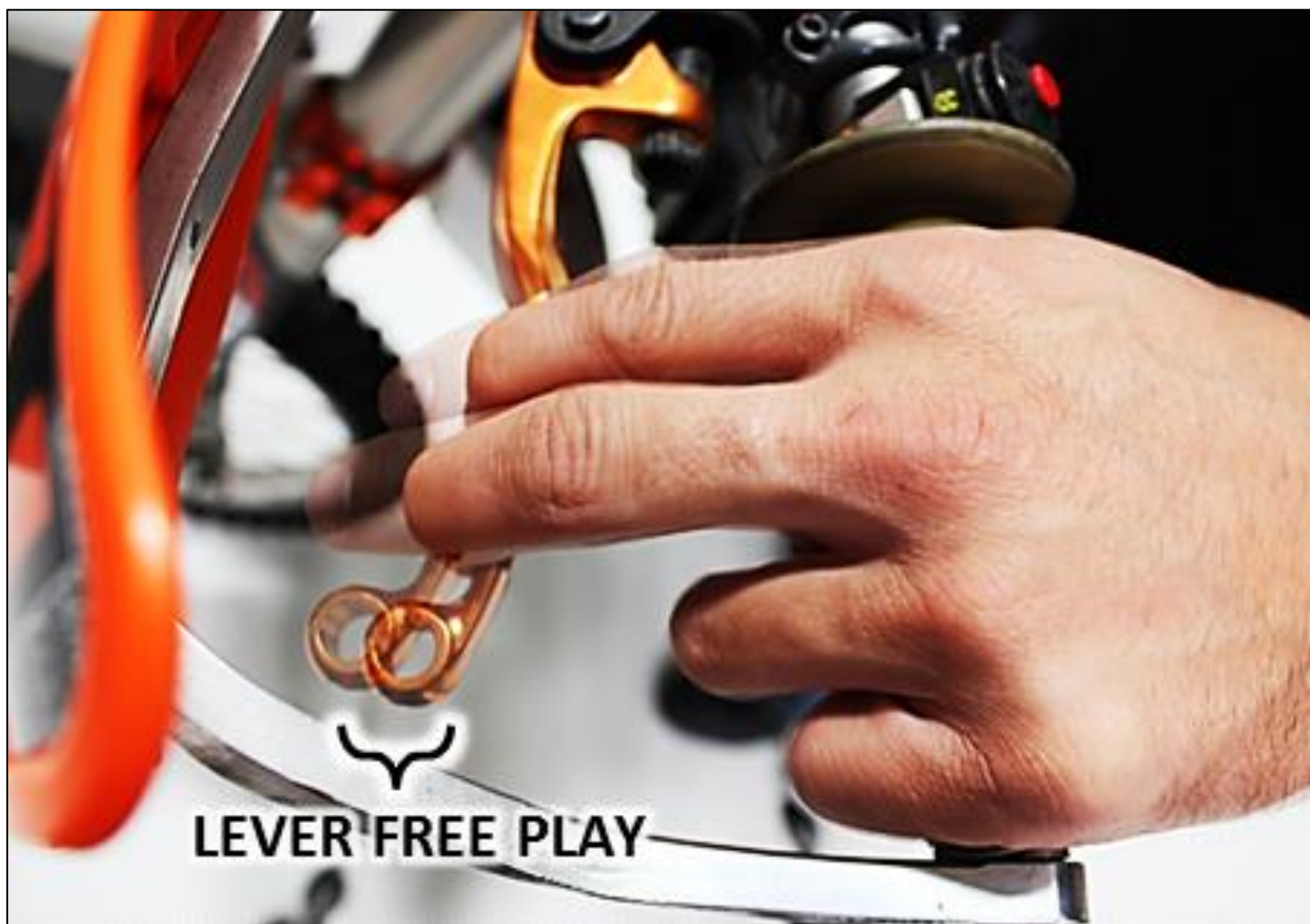

“**Free Play Gain**” is the increase of lever free play as the auto-clutch engages. This happens when the RPM increase from idle through around 5000 RPM. Free Play Gain is caused by the expansion of the EXP disk which lifts the pressure plate away from the throwout assembly.

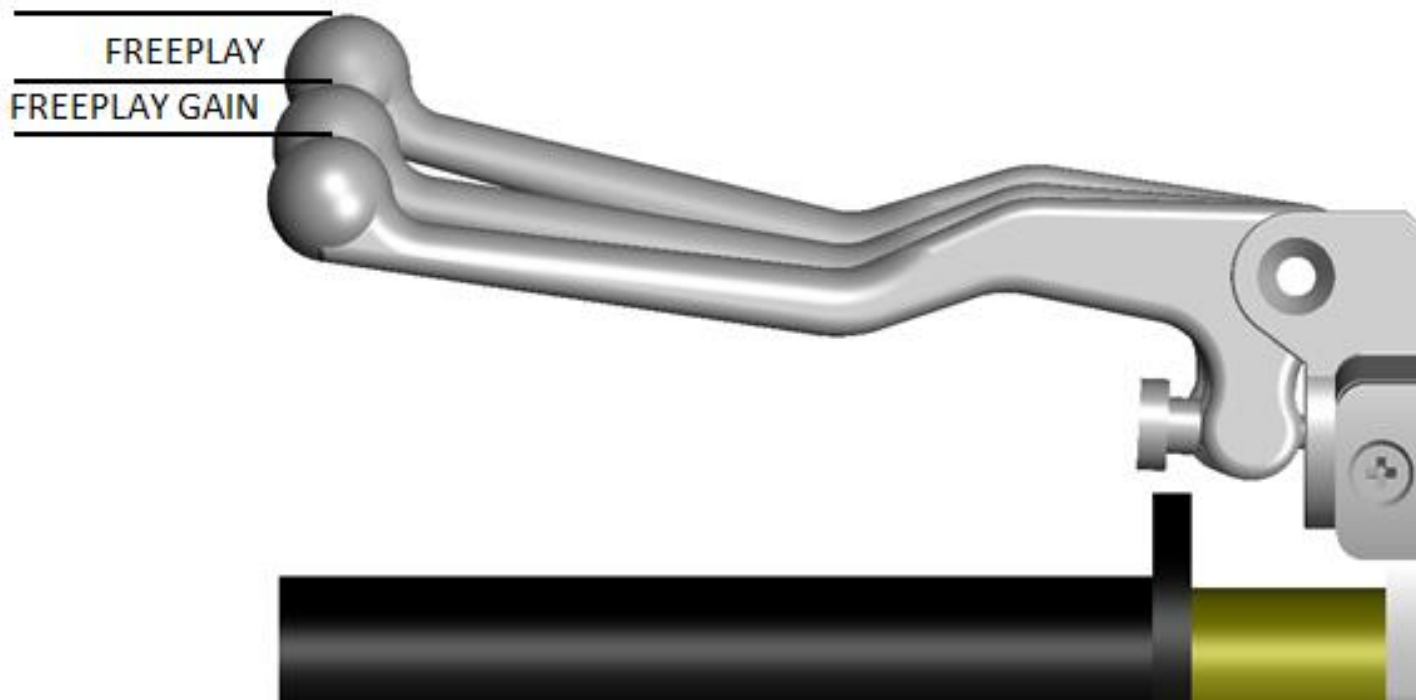

Optimal Free Play Gain yields **1/8-1/4” (3mm-6mm)** of clutch lever movement, measured at the end of the lever. This measurement at the lever correlates to achieving the ideal installed gap.

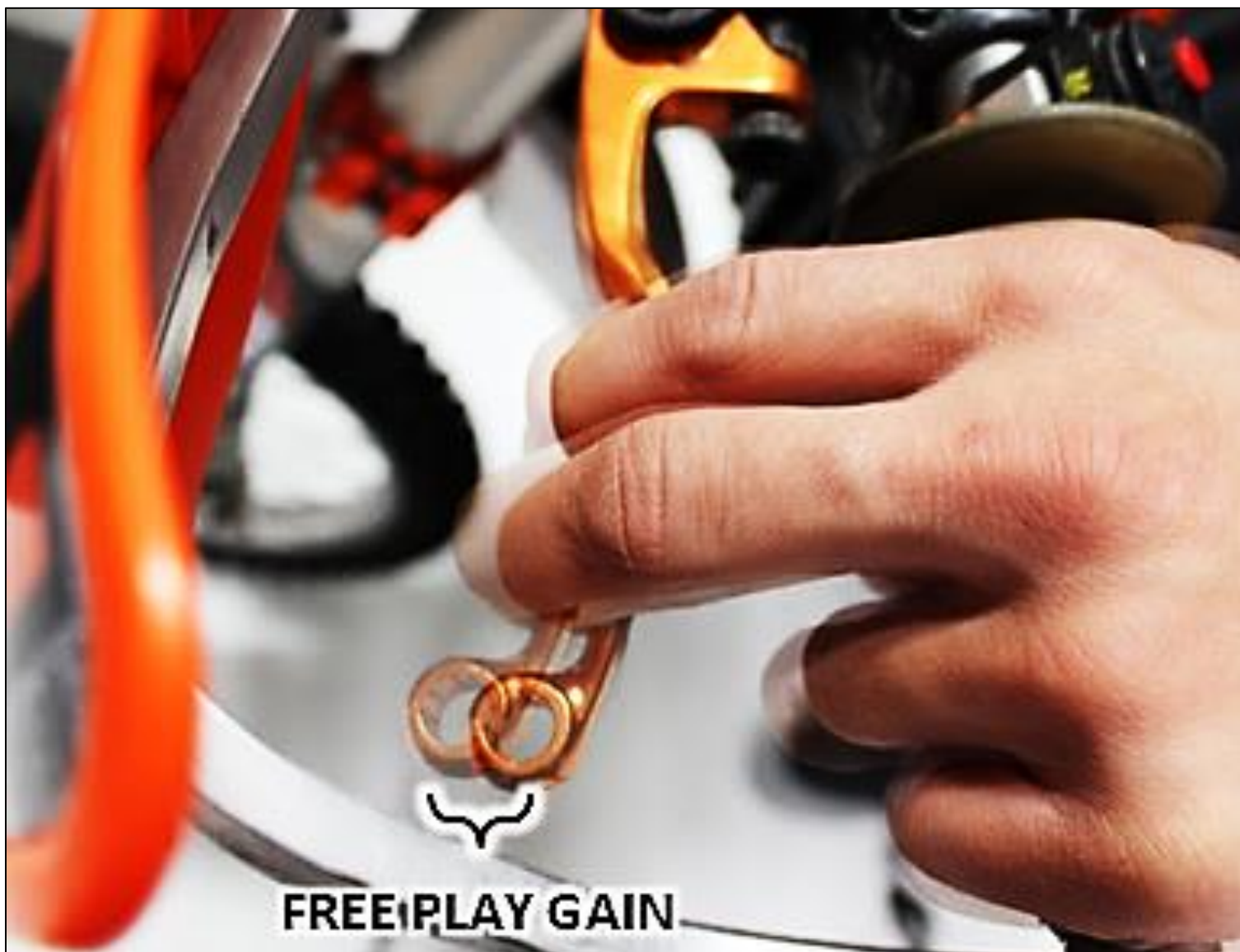

The following steps explain two ways to check Free Play Gain. One will use the rubber band that has been included in the clutch kit and one explains using your hand, which you will perform before every ride.

Place the bike in neutral, start the engine and let it warm up for 2-3 minutes.

RUBBER BAND METHOD

29. We recommend that you use this method to find your initial “Free Play Gain” so you can see what it is. We recommend also checking it by hand as explained in the next step so you can check free play gain both ways.

Wrap the included rubber band around the outer end of the handlebar grip and attach to the ball end of the clutch lever. See the following three photos for an example.



HAND METHOD

30. Free play gain can also be checked by using your hand and holding light pressure on the lever. With the bike at idle, pull on the clutch lever lightly with a single finger so the lever free play is taken up, but the clutch is not disengaged. While continuing to apply light pressure, rev the engine to at least 5000 RPM. **The clutch lever should move in 1/8 - 1/4” (3mm – 6mm) under your finger pressure as you rev the engine.**

NOTICE

If you are not getting the correct lever movement, see the “Free Play Gain Troubleshooting Guide” on the next page.

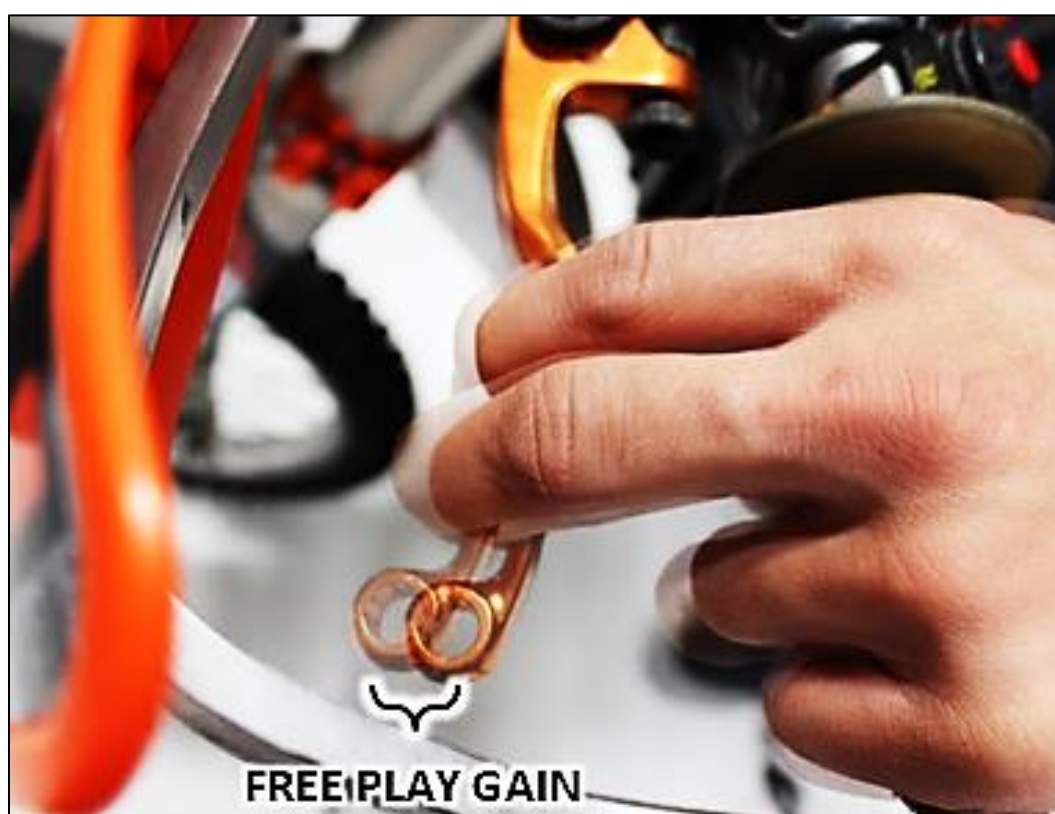

Free Play Gain Troubleshooting

Each adjustment should be done in small increments - one tick mark at a time. After each adjustment, repeat the rev-cycle until optimal free play gain is achieved.

Symptom:

- Clutch lever moves in too far (too much free play gain)
- Clutch has excessive drag
- It is difficult to fully override the clutch with the lever

Answer: Installed Gap is too small

Solution: Turn the Adjuster Screw inwardly (clockwise) to increase the Installed Gap.

Symptom:

- Clutch lever does not move enough or does not move at all (too little free play gain)
- Clutch is slipping

Answer: Installed Gap is too large

Solution: Turn the Adjuster Screw outwardly (counter-clockwise) to reduce the Installed Gap. It may be helpful to re-find the starting point.

BREAK-IN PROCEDURE

After desired free play gain is achieved, it is time to break in the EXP disk.

31. REV CYCLES: With the transmission in neutral and no pressure on the clutch lever, rev the engine to about 5000 rpm and let it return to idle. Perform 10 rev cycles.

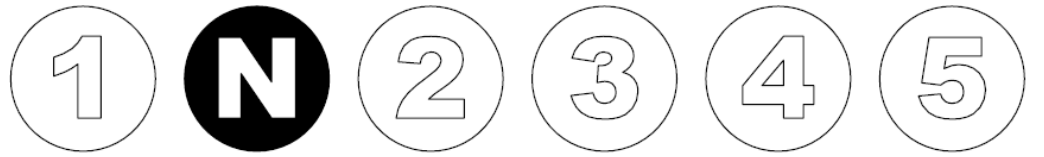

32. ROLL-ON STARTS: Pull in the clutch lever and click the transmission into first gear. Slowly release the clutch lever. The engine should stay running and the bike should have minimal forward creep. If the engine wants to stall or the creep is excessive, the idle may be too high or the installed gap may be too small. Make necessary adjustments before proceeding.

a. FIRST GEAR: Slowly roll on the throttle to begin moving. Accelerate to around 5000 rpm and come to a stop. Perform 10 first gear roll-on starts.

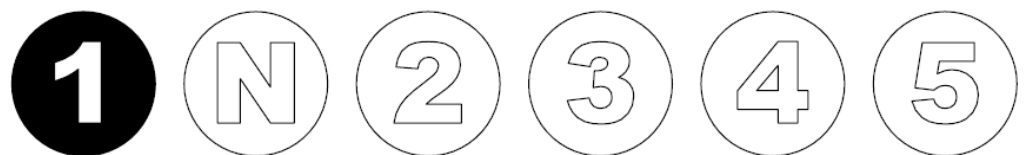

b. SECOND GEAR: Click the transmission into second gear and perform 10 roll-on starts.

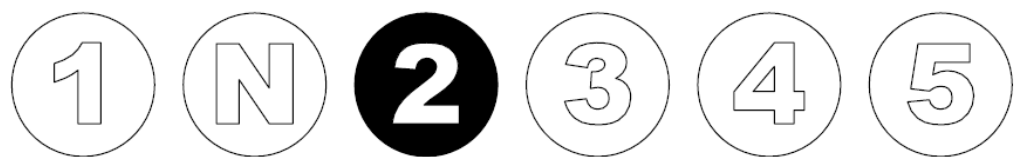

c. Re-check free play gain and adjust if necessary.

33. **4 strokes only:** It is normal for some clutch debris to be produced during break in. Following break-in, remove the OEM oil screen beneath the shift lever. Inspect the screen for clutch debris and clean if necessary.

⚠ WARNING

Failure to follow the break-in procedure and oil screen inspection process could cause motor oil delivery failure which can result in motor failure, serious injury, or death.

NOTICE

Check Free Play Gain before every ride.

Do not perform 3rd gear starts with this product. 3rd gear starts over time will burn up the clutch and decrease the performance of this product in a short amount of time.

⚠ WARNING

DO NOT RIDE WITHOUT SUFFICIENT FREE PLAY GAIN!

Checking free play gain is easy and takes less than a minute to perform. For optimum performance and longevity, check freeplay gain when the bike is warm at the start of every ride.

MAINTENANCE

Maintenance Protocol (see setup sheet)	Maintenance Interval
Check and verify free play gain	Every ride
Inspect all clutch parts for excessive wear or heat. Replace as needed.	40 hours

OPTIMIZING EXP ENGAGEMENT

For best performance, engine idle speed should be **slightly** adjusted to match the EXP engagement setting.

NOTE: Make sure Free Play Gain is optimal before adjusting idle speed.

With correct Free Play Gain and the bike in gear, the bike should move forward under slight opening of the throttle. If not, one of the following symptoms is likely:

- HIGH IDLE – the bike moves forward with the throttle fully closed. Solution: reduce idle RPM.
- LOW IDLE – the bike moves forward after engine RPM becomes noticeably higher than idle RPM. Solution: increase idle RPM.

NOTICE

If a slight idle adjustment does not alleviate the problem refer to the EXP tuning options below for an additional tuning.

EXP TUNING OPTIONS

Included are spring options to tune the engagement RPM of the EXP disk. The EXP disk comes set with the recommended “**Medium**” setting from Rekluse.

ENGAGEMENT SETTING	SPRING CONFIGURATION			
	350 4-stroke	450/500/501 4-stroke	250/300 2-stroke (Pre 2017)	250/300 2-stroke (2017+)
Low	6 Silver	6 Blue	6 Silver	6 Steel
Medium	3 Silver & 3 Red	3 Blue & 3 Gold	3 Silver & 3 Red	3 Silver & 3 Steel
High	6 Red	6 Gold	6 Red	6 Silver

Adjusting the engine idle speed to match your engagement setting is important and greatly affects the overall feel of how the EXP disk engages. To prevent freewheeling and maximize engine braking, set the idle so there is a slight amount of drag while the bike is idling in gear and warmed up. The idle should not be so high as to move the bike forward in gear with the throttle closed. However, with a small opening of the throttle the bike should move forward.

It is **NOT necessary** to disassemble the EXP halves to change springs! To change springs, remove 3 of the ¼-turn pins from one side of the EXP, replace springs, and re-install ¼-turn pins. Next, flip the EXP disk over and repeat on the other side if necessary. To maintain even pressure when using two different color spring sets, install one color set of 3 on one side of the EXP and the remaining color set of 3 on the other side.

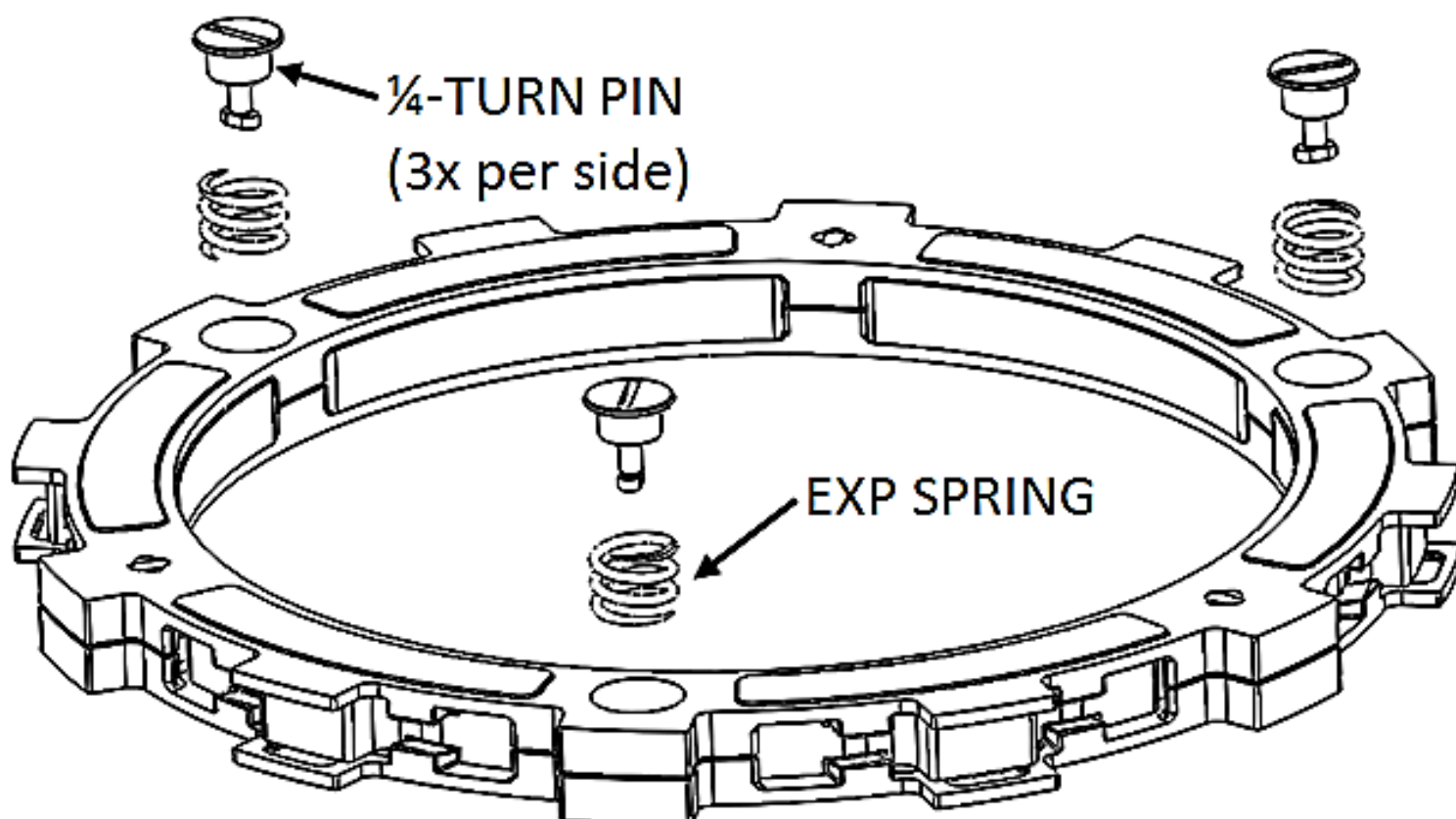

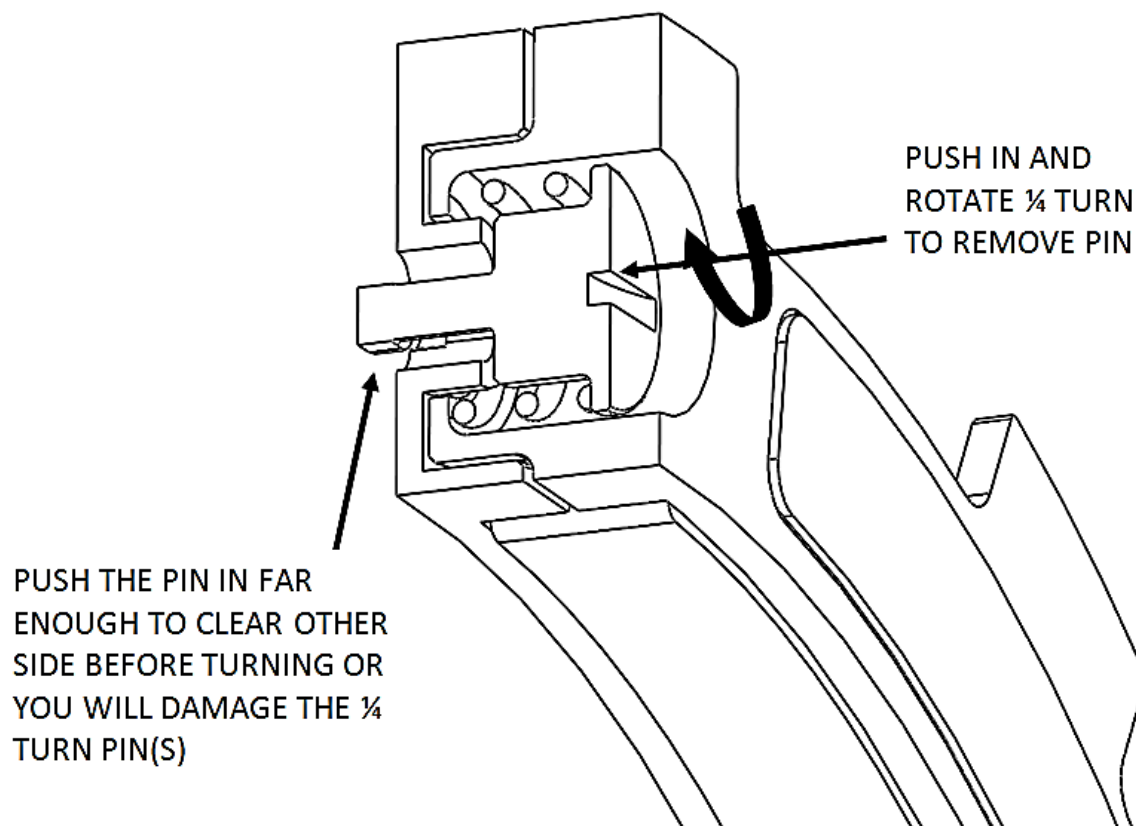

Clutch Squeal and Chatter

Although it is harmless, some bike models may have “squeal” or “chatter” coming from the clutch at low RPM as it engages. Clutch squeal is caused by the clutch components vibrating as the clutch engages and can become more audible as the clutch gets hot. For bike models that tend to have clutch squeal or chatter here are some recommendations to reduce or eliminate it:

- Oil: Rekluse recommends that you have fresh, clean JASO-MA or JASO-MA2 rated oil for best clutch performance. Dirty or old oil can make the clutch more likely to squeal or chatter.

BUMP-STARTING INSTRUCTIONS

If your vehicle needs to be bump-started due to a dead battery or any other reason, follow the steps below to quickly bump-start your vehicle.

1. Use your adjustable slave cylinder to collapse the gap until no resistance is felt.
2. Bump start the vehicle. The clutch will function like a manual clutch at this point, but the clutch will not be fully over-rideable at high RPMs.
3. Once the vehicle is started, readjust the gap to set the installed gap.

REKLUSE®



©2016 Rekluse Motor Sports
 Rekluse Motor Sports, Inc.
 12000 W Franklin Rd
 Boise, Idaho 83709
 208-426-0659
 support@rekluse.com