



YOSHIMURA

RESEARCH & DEVELOPMENT OF AMERICA, INC.

5420 DANIELS STREET STE A, CHINO CA. 91710 · (800)634-9166 · (909)628-4722 · FACSIMILE (909)591-2198

www.yoshimura-rd.com

TRC PERFORMANCE EXHAUST SYSTEM

HONDA
2003-2012
RUCKUS

1290072	STAINLESS STEEL FULL SYSTEM WITH CARBON FIBER SLEEVE AND ENDCAP
1290075	STAINLESS STEEL FULL SYSTEM WITH STAINLESS STEEL SLEEVE AND ENDCAP

NOTE: THIS SYSTEM IS DESIGNED FOR USE IN CLOSED COURSE COMPETITION AND IS NOT INTENDED FOR ANY OTHER USE.



THIS PRODUCT IS DESIGNED FOR USE IN CLOSED COURSE RACING AND IS NOT INTENDED FOR ANY OTHER USE.



NOTE: IN THE STATE OF CALIFORNIA, IT IS ILLEGAL TO MODIFY THE EMISSION CONTROL SYSTEM. WHICH INCLUDES THE CARBURETORS OF ANY VEHICLE.

Caution: Exhaust system can be extremely hot. Let motorcycle cool down before beginning installation. Always wear hand and eye protection and take precautionary measures to avoid injury.

Note: Read through all instructions before beginning installation.

Tools Needed:

Metric Socket Set, Ratchet, and Extension
Metric Open End Wrenches
Torque Wrench

Installation Steps:

1 Remove stock muffler. (Fig. 1)

- Remove bolt that connects muffler to rear fender.
- Loosen the two muffler chassis mount bolts.
- Remove stock header flange nuts.
- Remove chassis mount bolts.
- Remove muffler from scooter.



Fig. 1

2 Install Yoshimura muffler.

-Install muffler mounting bracket to stock chassis mount location. Orientation is as follows: Supplied bolt, bracket, spacers, bracket, chassis. Torque to 16.5 lb-ft (23 Nm). (Fig. 2)

-Install Yoshimura header into exhaust port using stock nuts. Do not torque at this time.

-Install Yoshimura fender mount bracket onto muffler using supplied bolts.

-Insert rubber heatshield into Yoshimura muffler clamp.

-Place clamp onto Yoshimura muffler.

-Insert Yoshimura muffler onto header.

-Mount Yoshimura muffler to muffler bracket. Orientation is as follows: Supplied bolt, washer, muffler clamp, spacer, muffler bracket, nut. Do not torque at this time. (Fig. 3)

-Install supplied exhaust spring onto muffler and header.

-Bolt fender to fender mounting bracket using stock bolt and supplied nut.

-Torque stock header nuts to 7 lb-ft (10 Nm).

-Torque muffler mounting bolt to 14 lb-ft (19 Nm).

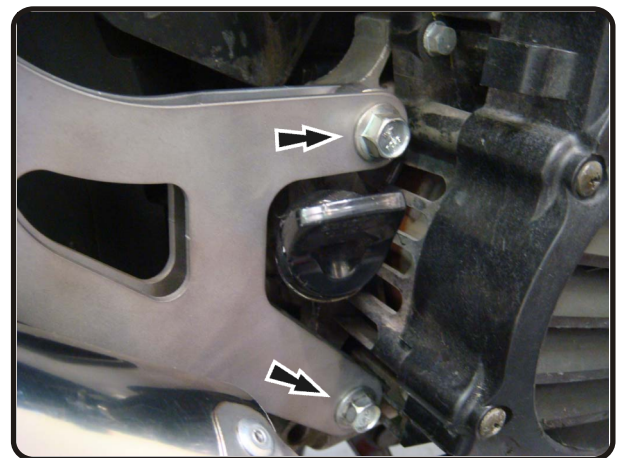

Fig. 2

3 It is recommended that the muffler and tailpipe be wiped down with rubbing alcohol to remove oil and fingerprints. This will help prevent tarnishing of the finish after the exhaust is heated up.

4 Check for proper clearance between new exhaust system and rear suspension (i.e. tire, swing-arm, brake, etc). If any problem is found, please carefully follow through the installation steps again. If problem still persists, please call Yoshimura tech department at (800)634-9166 / in CA (909) 628-4722.



Fig. 3

NOTE: After starting motorcycle, it is normal for new exhaust system and muffler to emit smoke until oil residue burns off.

#129007(2,5)

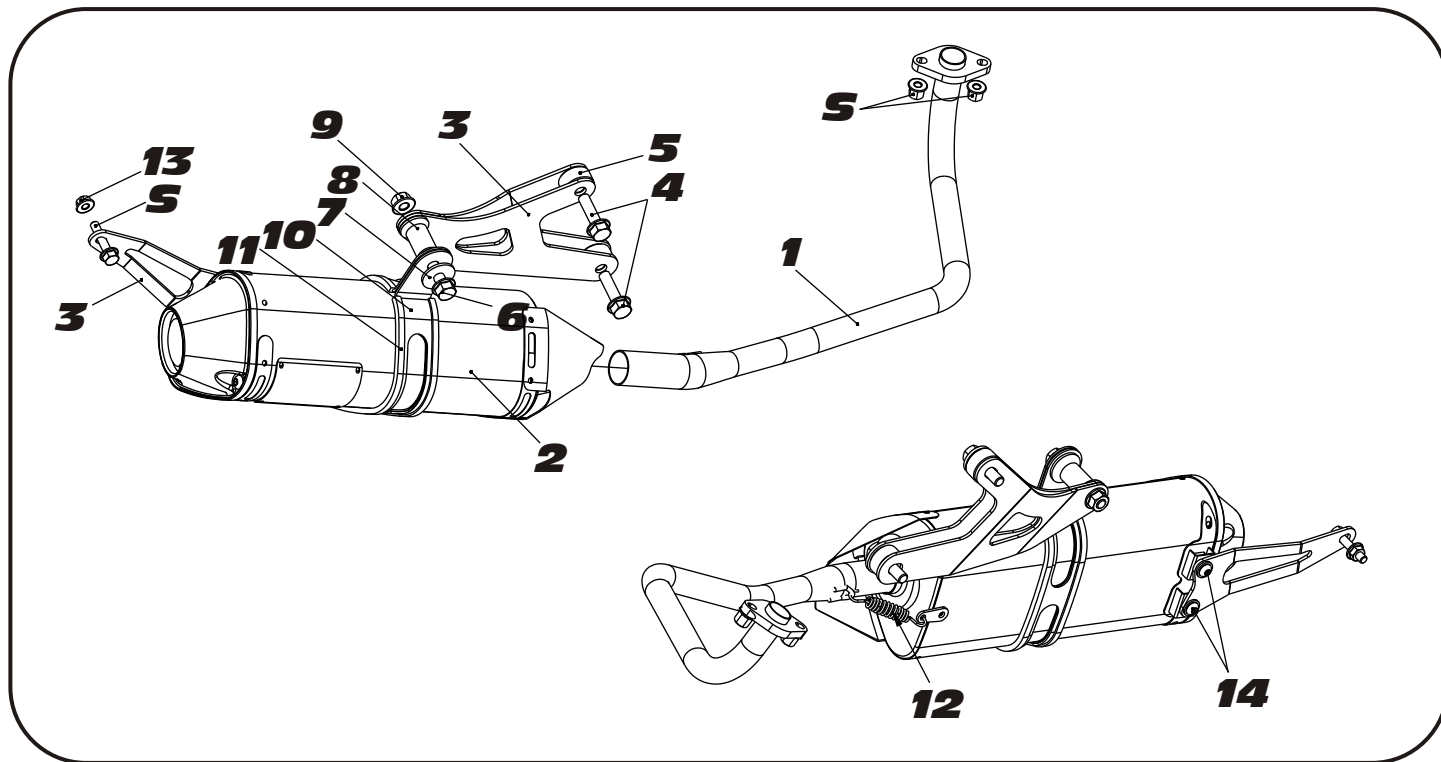

Parts Diagram

NO.	DESCRIPTION	QTY	PART #
1	Yoshimura Header	1	1290-101
2	Yoshimura Muffer with Carbon Fiber Sleeve with Stainless Steel Sleeve	1	1290072-RMA 1290075-RMA
3	1290 Muffer Bracket (3 pc.)	1	1290-BRKT-00
4	8mm X 30mm Flanged Hex Bolt	2	M8X30H
5	8mm X 12mm Aluminum Spacer	2	8X12SPC
6	8mm X 55mm Flanged Hex Bolt	1	M8X55H
7	8mm Flat Washer	1	8MMWASHER
8	20 X 8.5 X 35 Step Aluminum Spacer	1	8X35SPCR
9	8mm Flange Nut	1	8MMNUT
10	TRC Muffer Clamp for 1290075 for Carbon Fiber for Stainless Steel	1	1290-MPCA 1290-MPCAX
11	Slotted Heatshield for Muffer Clamp	1	HT SHLDR77
12	Spring, Short w/ Insulator	1	RACE-SPX-1
13	6mm X 1.0 S/S Hex Nut	1	6MMNUT
14	6X8mm Flange Button Head Screw	2	RC116HSB
**	Spring Puller Tool	1	ST-200
**	Yoshimura Sticker Kit Sheet	1	17029

WARNING

**IN THE STATE OF CALIFORNIA,
IT IS ILLEGAL TO MODIFY THE
EMISSION CONTROL SYSTEM.
WHICH INCLUDES THE
CARBURETORS OF ANY
VEHICLE.**

***Closed Course Competition
Jetting Recommendations:
Main Jet: Keihin 80S
Pilot Jet: Stock***